

Tracking down the source of a dusting problem with your dust collector doesn't have to take you on a wild goose chase. The step-by-step approach outlined in this article can help you quickly identify what's behind the dusting so you can fix the problem.

OVERVIEW

When your bag or cartridge filter dust collector is working the way it should, air and dust enter the collector's dirty-air plenum, and the air passes through the filter media while the dust is deposited on the media's dirty side. The clean air exhausts from the collector's clean-air outlet, and the collector's filter-cleaning system uses mechanical shaking, reverse air, or pulsed compressed air to purge the dust from the media so it can drop into the collector's dust hopper for discharge. This process is shown for a cartridge dust collector in Figure 1. But when fine dust is emitted through your dust collector's clean air outlet, something's gone wrong, whether in the collector itself or elsewhere in your plant. Checking for the following potential causes in the order listed here can help you quickly pinpoint the dusting's source so you can remedy the problem.

1. SEALS AND GASKETS

Check first for damaged or missing seals and gaskets in your dust collector. Make sure that all seals and gaskets have been installed and seated properly and without

damage, especially if any have been replaced recently. Ask the operator about environmental factors, such as heat, acids, or abrasion, in your application that could cause the seals or gaskets to deteriorate over time. If the filters have been replaced recently, make sure that the filters and the gaskets between them and the tubesheet were installed according to the collector manufacturer's recommendation. Also check that any aftermarket filters or gaskets are the correct size. When improperly installed or sized, seals and gaskets can create gaps or openings between the filters and the tubesheet that allow dust to pass directly through the tubesheet. (Find more information in the later section "4 Tubesheet and collector housing.")

If you can't easily spot leaks in the seals or gaskets, you may need to bring in a qualified dust collector service technician. The technician can introduce a fluorescent trace powder into your dust collection system's dirty side and then use a black light to illuminate the collector's clean-air plenum to pinpoint where the trace powder has leaked through the tubesheet.

Figure 1: Cartridge dust collector operation

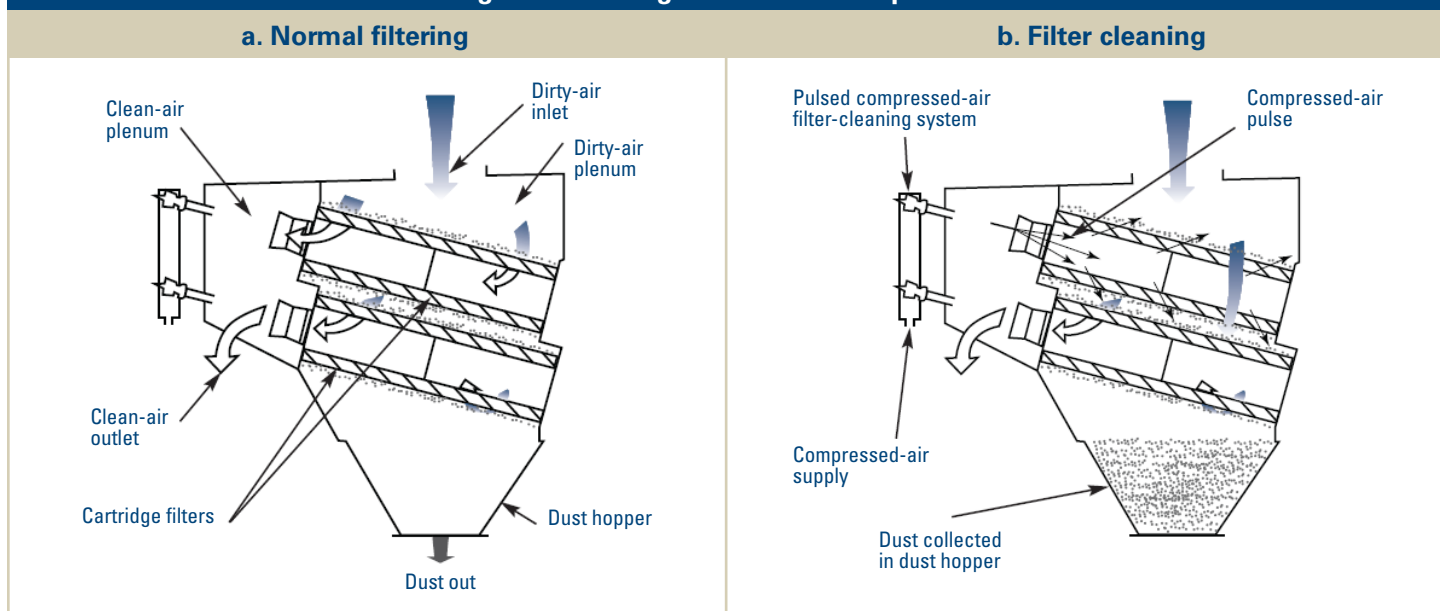

2. FILTER MEDIA

If you still haven't identified the dusting's source, check for problems with the filter media. If the filters have been replaced recently, verify that they're constructed of the same media that was working successfully before. If it's a new media, make sure that it can handle your application and environment. Also be aware that a clean media has a much lower airflow resistance than the dirty media it's replacing; depending on the airflow and static pressure capabilities of your collector's exhaust fan, the lower resistance can result in excessive airflow through the collector. If the media exhibits any damage or deterioration — such as thermal damage, chemical damage, or physical damage caused by abrasion or handling — investigate what's behind it and try to eliminate the problem. For instance, if the media has been damaged by high-velocity abrasive dust, modifying the dirty-air inlet or reducing the dirty air's inlet velocity may reduce or eliminate the damage.

3. FILTER-CLEANING SYSTEM

The next thing to check is the operation of your collector's filter-cleaning system. It's possible that the system is overcleaning and removing too much of the dust cake from the filter, reducing the media's overall filtration efficiency. The most efficient filter has a dust cake, so if you see that the filters have almost no dust cake or none at all, leave the cleaning system's lower cleaning limit (that is, the setting at which the cleaning cycle is initiated) at around 1 to 2 inches of water above the clean filter's initial airflow resistance. This will ensure that a dust cake remains on the filter, adding to its filtration efficiency.

The reverse could also be the culprit. If the cleaning system is undercleaning the filters by not using the proper cleaning energy recommended by the collector manufacturer, too much dust can be left on the filter, restricting airflow through the filters and causing the collector to operate at a higher pressure drop. If the dust collector is cleaned with pulsed compressed air, for instance, undercleaning can result from an inadequate compressed-air supply or an inadequate pulsing frequency or duration. Also make sure that the cleaning system is delivering dry, clean instrument-quality air at the pressure recommended by the collector manufacturer to prevent introducing moisture or other contaminants into the collector and to ensure that the pulses supply adequate cleaning energy.

Running a mechanical shaking filter-cleaning system online — that is, while air is still flowing through the

collector — can result in dusting through the tubesheet. If you have this type of filter-cleaning system, running it online is *not* advised.

4. TUBESHEET AND COLLECTOR HOUSING

Next, look for filters that aren't sealed properly against the tubesheet. If you're using cartridge filters, besides checking the integrity of the gasket between the filter and tubesheet, make sure that the filters and gaskets are oriented correctly in the tubesheet holes to ensure that no dust can leak past the gaskets. Bag filters, especially those 12 feet or longer, could be swaying or otherwise moving excessively, which can cause momentary leaks as the filters' wire cages separate from the tubesheet during filter movement. Also check that the tubesheet surface where the filter gaskets are seated is clean. If you install filters without removing dust and debris from this surface, the gaskets may not form a tight seal.

Another dusting source can be a housing leak that produces an unexpected airflow pattern in the collector. Such a leak can be caused by abrasion from dust hitting the collector's inside wall or dust leaking from the hose on a drum or other container cover below the hopper outlet. For instance, air entering through a leak low in the collector wall can increase the ratio of fine dust entrained in the airflow inside the collector, changing the dust's composition and possibly overwhelming the collector's filtration capability. Besides creating dusting problems, such leaks can reduce filtration efficiency, produce a higher pressure drop across the filters, increase media abrasion, and increase the load on the filter-cleaning system.

5. AIRFLOW

Still looking for your dusting problem's source? It's time to consider whether your collector may be undersized for its current airflow and application. Every dust collection system is originally designed with an optimal airflow through the collector to meet its application requirements and to conform to American Conference of Governmental Industrial Hygienists (ACGIH) guidelines and practices.¹ But more often than not, the system is modified over the years: Equipment is replaced or unit operations are added to the process line to handle growing market demand for your product, capture hoods and system ducts are added, the duct layout leading to the collector is altered, or the collector's exhaust fan is replaced with a bigger unit. If such changes are made without considering the system's overall filtration efficiency, they can tax your

collector well beyond its design capabilities and lead to dusting headaches.

To determine if improper airflow through your dust collection system is causing dusting, re-evaluate the system's design and performance. Evaluate your existing system against its original installed condition, and consider how any changes may have caused the system to deviate from ACGIH guidelines. Pay special attention to proper airflow through the ducts in a system that includes a cyclone, because the cyclone's efficiency greatly depends on adequate airflow. If your system includes a used dust collector, make sure that it's correctly applied and sized for your application so it has the proper airflow to perform efficiently.

Dusting can also result from failing to damper the system airflow after new filters are installed in the collector. When this step is skipped, the result can be an immediate depth loading of the filters (that is, dust penetration deep into the media, where the dust is very difficult to clean out), media abrasion, and shortened filter life, any of which can lead to dusting. After replacing the filters, it's best to damper the system airflow so the new filters' bare media doesn't pull more than the design airflow through your collector before the dust cake has a chance to form. To prevent this problem and help you achieve optimal airflow over your filters' service life, you can install a damper on the clean-air outlet and adjust it to reduce the system airflow after new filters are installed. You can also use an exhaust fan with a variable-frequency drive to not only provide optimal airflow over your filters' life, but save energy by not using the fan motor's full load when the filters are new and have a lower pressure drop.

6. SOURCES OUTSIDE THE COLLECTOR

When none of the previous steps have pinpointed your dusting problem's cause but your collector still seems to be leaking, it's time to consider other sources. The collector may not be leaking at all. If your collector is indoors in a dusty environment with its clean-air outlet directed at a wall or other surface, dust sometimes appears to be emitting from the outlet, especially if the outlet is aimed at a white or clean surface. In this case, the clean air exiting the outlet is pulling dirty ambient air from your plant along with it, slinging the dust against the clean surface and creating the appearance of dusting through the collector. In this situation, you need to find ways to improve the ambient air's cleanliness.

Another dusting source outside your collector can be poor connections or leaks in the dust collection system ductwork, especially if the system operates under positive pressure. Dust can leak through any poorly sealed duct connections or duct holes created by abrasive wear. Sealing these connections and holes should be all it takes to eliminate this dust source.

FOR FURTHER READING

Find more information on troubleshooting dust collection systems in articles listed under "Dust collection and dust control" in *Powder and Bulk Engineering's* comprehensive article index (in the December 2010 issue and at *PBE's* Web site, www.powderbulk.com) and in books available on the Web site at the *PBE* Bookstore. You can also purchase copies of past *PBE* articles at www.powderbulk.com.

¹ For more information on ACGIH guidelines and practices, go to www.acgih.org.

Andy Sorenson: Lead application engineer at Donaldson Torit, PO Box 1299, Minneapolis, MN 55431; 800-365-1331, ext. 3929, or 952-887-3929, fax 952-698-2479 (andrew.sorenson@donaldson.com, www.donaldson.com). He holds a BS in engineering technology with a concentration in mechanical design from the University of Wisconsin-Stout in Menomonie.



Donaldson Company, Inc.
Torit
P.O. Box 1299
Minneapolis, MN
55440-1299 U.S.A.

Tel 800-365-1331 (USA)
Tel 800-343-3639 (within Mexico)

donaldsontorit@donaldson.com
donaldsontorit.com