



Vibra Shake™

Model VS-550, VS-1200, VS-1500
VS-2400, and VS-3000

Installation and Operation Manual

Installation, Operation, and Service Information

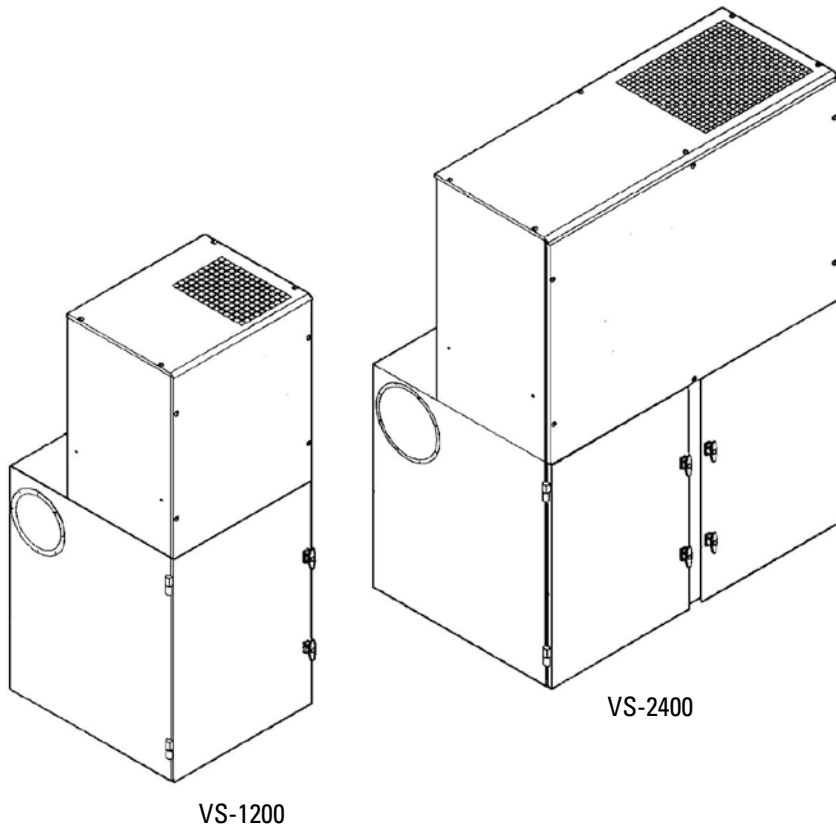

This manual is property of the owner. Leave with the unit when set-up and start-up are complete. Donaldson Company reserves the right to change design and specifications without prior notice.

Illustrations are for reference only as actual product may vary.



This is the safety alert symbol. It is used to alert you to potential personal injury hazards. Obey all safety messages that follow this symbol to avoid possible injury or death.



APPLICATION OF DUST CONTROL EQUIPMENT

Combustible materials such as buffing lint, paper, wood, metal dusts, weld fume, or flammable coolants or solvents represent potential fire and/or explosion hazards. Use special care when selecting, installing, and operating all dust, fume, or mist collection equipment when such combustible materials may be present in order to protect workers and property from serious injury or damage due to a fire and/or explosion.

Consult and comply with all National and Local Codes related to fire and/or explosion properties of combustible materials when determining the location and operation of all dust, fume, or mist collection equipment.

When combustible materials are present you must consult with an expert in fire extinguishing and/or explosion protection systems, who is also familiar with the local codes, for support and guidance on the selection and installation of an appropriate fire and/or explosion protection system.

DO NOT allow sparks, cigarettes or other burning objects to enter the hood or duct of any dust, fume, or mist collection equipment as these may initiate a fire or explosion of any combustible materials accumulated in the collector.

Portions of dust, mist, and fume-collection equipment, including the clean- and dirty-air plenums may be considered "OSHA Confined Spaces." Refer to the appropriate OSHA regulations to determine if a specific installation should be considered a confined space and if a permit program is required.

Recirculating filtered air in your facility can be a hazard. Consult with OSHA to ensure compliance with all codes regarding recirculating filtered air.

Improper operation of a dust, fume, or mist control system may contribute to conditions in the work area or facility that could result in severe personal injury and product or property damage. Check that all dust, fume, or mist collection equipment is properly selected, installed, and operated for its intended use.

This manual contains specific precautionary statements relative to worker safety. Read this manual thoroughly and comply as directed. Instruct all personnel on the safe use and maintenance procedures related to this equipment. Discuss any questions on the application, use, or maintenance of this equipment with a Donaldson Torit representative.

For optimum collector performance, use only Donaldson Torit replacement parts.

Data Sheet

Model Number _____	Serial Number _____
Ship Date _____	Installation Date _____
Customer Name _____	
Address _____ _____	
Filter Type _____	
Accessories _____	
Other _____	

Contents

Description.....	1	Preliminary Start-Up Check	10
Purpose and Intended Use.....	1	Maintenance Information.....	11
Rating and Specification Information.....	2	Operational Checklist	11
Operation.....	3	Filter Removal and Installation.....	11
Inspection on Arrival.....	4	Dust Disposal	12
Installation Codes and Procedures	4	Optional Equipment.....	13
Installation.....	4	55-Gallon Drum Pack.....	13
Site Selection, Grade-Mounted Units.....	4	5-Gallon Pail Pack.....	13
Unit Location	4	Control Box.....	15
Rigging Instructions.....	5	Shaker Assembly.....	16
Hoisting Information	5	Pressure Switch Connection.....	16
Electrical Wiring.....	5	Troubleshooting.....	17
Standard Equipment.....	6	Service Notes	19
Dust Drawer Units.....	6		
Hopper and Leg Installation	6		
Cabinet Assembly.....	7		
Ductwork	7		
Electrical Connection	8		



DANGER indicates a hazardous situation which, if not avoided, will result in death or serious injury.



WARNING indicates a hazardous situation which, if not avoided, could result in death or serious injury.



CAUTION, used with the safety alert symbol, indicates a hazardous situation which, if not avoided, could result in minor or moderate injury.

NOTICE

NOTICE is used to address practices not related to personal injury that may result in damage to equipment.

Description

The Vibra Shake, Model VS Collectors are high-efficiency, intermittent-duty dust collectors with cartridge-style filters for airflow ranging from 550 to 3,000 cfm. The patented, self-contained unit uses a high frequency, vibration filter cleaning system. A cellulose-based filter cartridge with a nylon mesh pre-filter provides optimum efficiency and ease of maintenance. The nylon mesh pre-filter accumulates a dust cake, and the cartridge acts as a cleanable secondary filter. The Vibra Shake dust collectors standard features include an acoustic-lined blower chamber and automatic filter cleaning.

Designed to increase the versatility of the unit, standard options include a variety of discharge arrangements, dust drawer or hopper-style cabinets, and 5- or 55-gallon dust disposal options.

Purpose and Intended Use

The two-stage filter design makes the VS collector especially effective on fibrous particulate or bimodal dust, which is a mixture of large and small particulate. The VS is for use on negative pressure systems only.

VS collectors are not recommended for applications with very fine, mono-sized nonagglomerative particulate such as welding fume. The filter cartridge will effectively filter the dust, but the high air-to-media ratios will not release the fine particulate from the filter during cleaning.

Typical VS applications include metal working, pharmaceutical, composite and precious metals industries.



WARNING

Combustible materials such as buffing lint, paper, wood, metal dusts, weld fume, or flammable coolants or solvents represent potential fire and/or explosion hazards. Use special care when selecting, installing, and operating all dust, fume, or mist collection equipment when such combustible materials may be present in order to protect workers and property from serious injury or damage due to a fire and/or explosion.

Consult and comply with all National and Local Codes related to fire and/or explosion properties of combustible materials when determining the location and operation of all dust, fume, or mist collection equipment.

Standard Donaldson Torit equipment is not equipped with fire extinguishing or explosion protection systems.

Rating and Specification Information

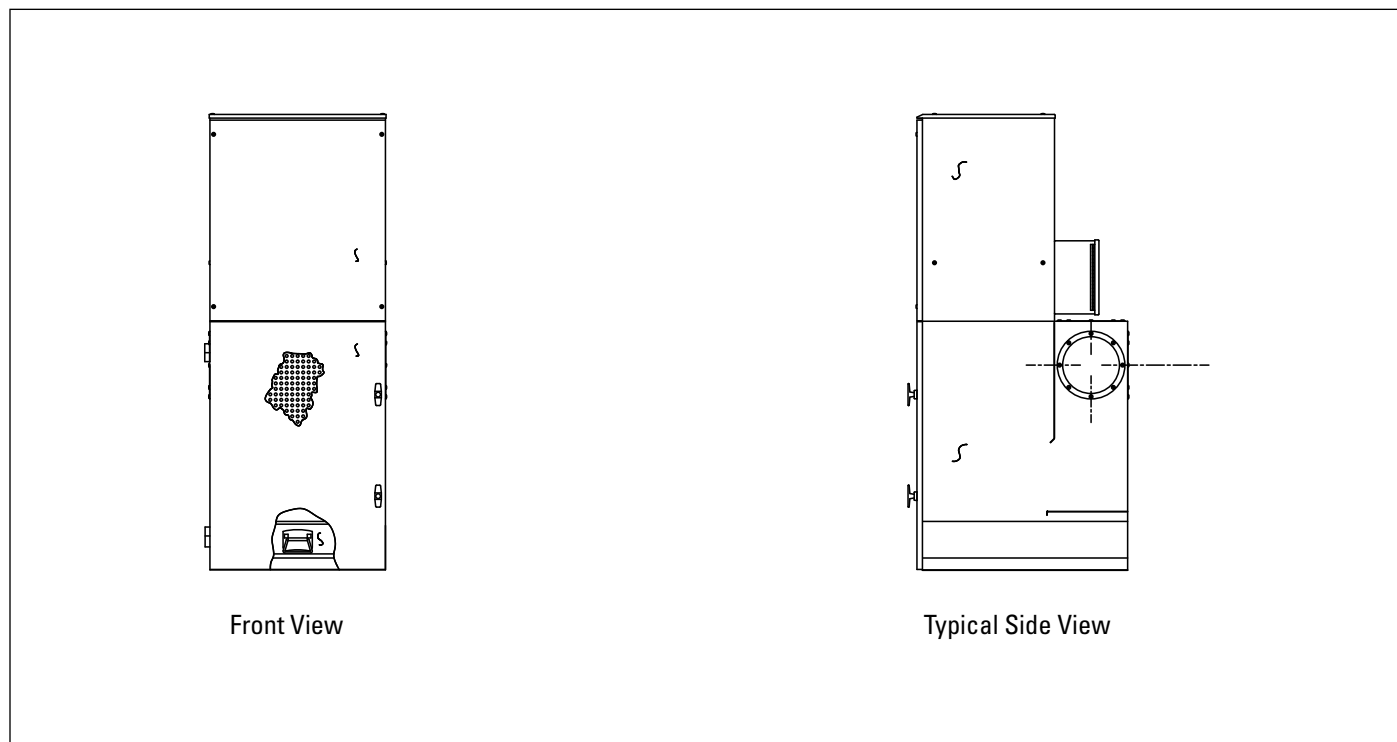

All Units (as per IBC 2006 Specifications*):
 Need to check each product line and change the
 information below to match and watch for IBC year.

- Seismic Spectral Acceleration, S 1.5 g
- Seismic Spectral Acceleration, S_1^s 0.6 g
- Occupancy Category II
- Housing rating, inches water gauge +/- 20
- Power, valves and controls 120-Volt 50/60 Hz

*If unit was supplied with a Record Drawing, the
 specifications on the drawing will supercede the
 standard specifications above.

Operation

Dust enters through the cabinet inlet and passes through a fine mesh pre-filter on the outside of the filter. The pre-filter is spaced 1-in from the filter cartridge and is designed to catch fibrous dust while fine particulate passes through to collect on the outside surfaces of the filter cartridge. Clean, filtered air flows up through the center of the filter cartridge to the blower, through the silencer, and exits through the top clean-air outlet.

Model VS is an intermittent-duty collector, which means that cleaning starts when the fan is turned OFF and the appropriate fan run-down time is complete. The solid-state timer automatically starts the cleaning sequence 60-seconds after the fan is turned OFF for the VS-550,

VS-1200, and VS-1500 and 180-seconds for Models VS-2400 and VS-3000. This is the fan run-down time. Power to controls must remain ON to operate cleaning mechanism.

The vibration motor starts and filter cleaning begins for a preset time of 30-, 60- or 90-seconds. A diaphragm at the bottom of the filter cartridge opens when the fan is turned OFF which allows fine dust particles to fall into the dust drawer or optional hopper for disposal.

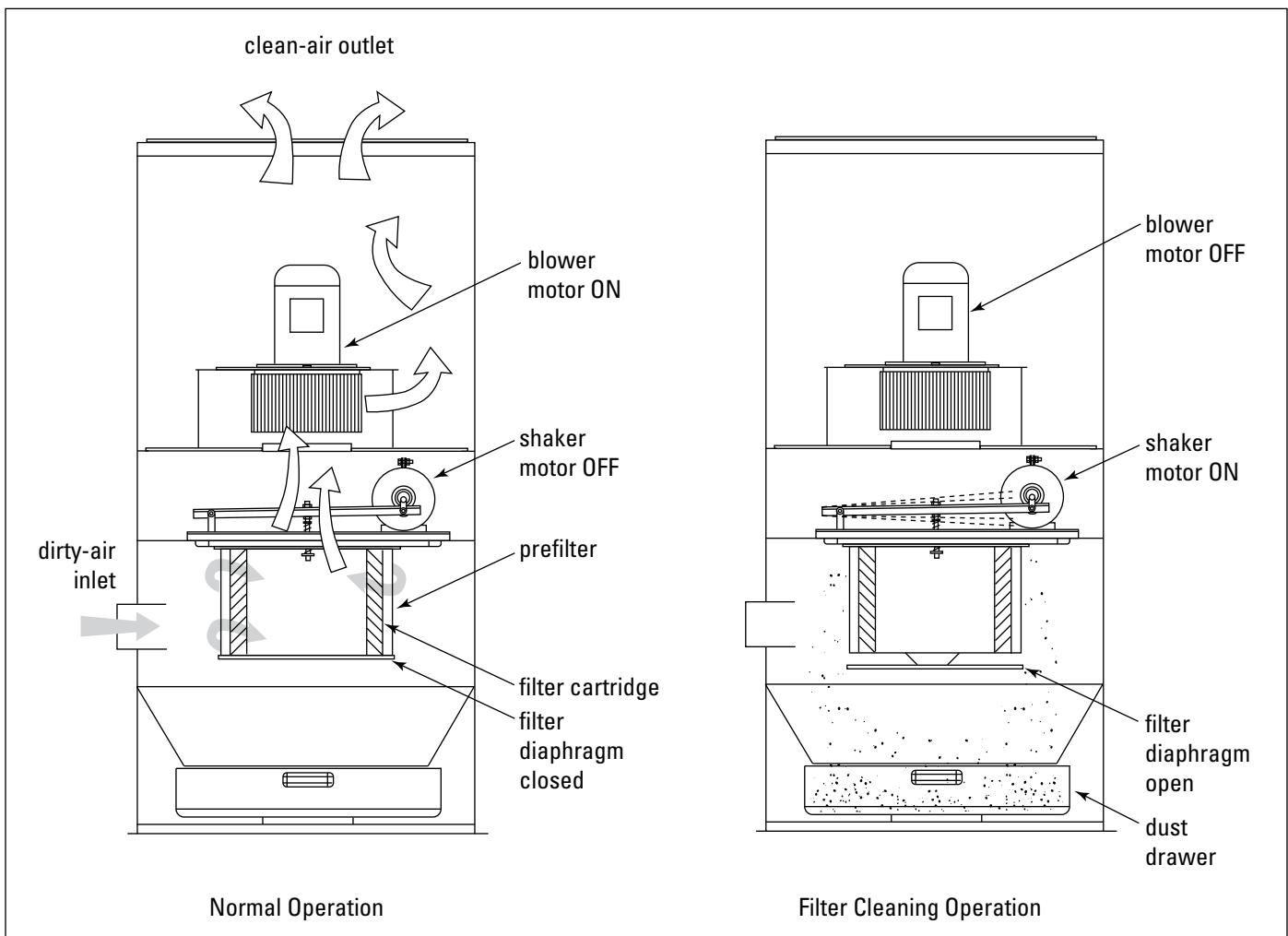

Unit Operation

Inspection on Arrival

1. Inspect unit on delivery.
2. Report any damage to the delivery carrier.
3. Request a written inspection report from the Claims Inspector to substantiate any damage claim.
4. File claims with the delivery carrier.
5. Compare unit received with description of product ordered.
6. Report incomplete shipments to the delivery carrier and your Donaldson Torit representative.
7. Remove crates and shipping straps. Remove loose components and accessory packages before lifting unit from truck.
8. Check for hardware that may have loosened during shipping.
9. Use caution removing temporary covers.

Installation Codes and Procedures



Codes may regulate recirculating filtered air in your facility.

Consult with the appropriate authorities having jurisdiction to ensure compliance with all national and local codes regarding recirculating filtered air.

Safe and efficient operation of the unit depends on proper installation.

Authorities with jurisdiction should be consulted before installing to verify local codes and installation procedures. In the absence of such codes, install unit according to the National Electric Code and NFPA No. 70-latest edition.

A qualified installation and service agent must complete installation and service of this equipment.

All shipping materials, including shipping covers, must be removed from the unit prior to, or during unit installation.

NOTICE

Failure to remove shipping materials from the unit will compromise unit performance.

Inspect unit to ensure all hardware is properly installed and tight prior to operating collector.

Installation



Wind, seismic zone, and other live-load conditions must be considered when selecting the location for all units. Reference the Rating and Specification Information.

Codes may regulate acceptable locations for installing dust collectors. Consult with the appropriate authorities having jurisdiction to ensure compliance with all national and local codes regarding dust collector installation.

Site Selection, Grade-Mounted Units

The unit can be located on a reinforced concrete foundation or rooftop.

Provide clearance from heat sources and avoid any interference with utilities when selecting the location for suspended units.

Portable units require no special installation accommodations.

When outdoor locations are selected, always mount motors with draw holes pointed down for proper drainage of moisture.

Unit Location



Donaldson Torit equipment is not designed to support site-installed

ducts, interconnecting piping, or electrical services. All ducts, piping, or electrical services supplied by others must be adequately supported to prevent severe personal injury and/or property damage.

When hazardous conditions or materials are present, consult with local authorities for the proper location of the collector

Foundation must be capable of supporting the entire weight of the unit, plus the weight of the collected material, piping, and ductwork.

Prepare the foundation in the selected location. Install anchor bolts to extend a minimum of 1 3/4-inches above foundation.

Locate the collector to ensure easy access to electrical and compressed-air connections and routine maintenance.

If explosion protection devices are part of the system, locate the collector in accordance with local code requirements (Example: NFPA 654). These codes may require units handling combustible dust be located either outside or against an exterior wall.

Rigging Instructions

Suggested Tools & Equipment

Clevis Pins and Clamps	Lifting Slings
Crane or Forklift	Pipe Sealant
Drift Pins	Pipe Wrenches
Drill and Drill Bits	Screwdrivers
End Wrenches	Socket Wrenches
Adjustable Wrench	Spreader Bars
Torque Wrench (inch/lbs, 9/16-in Socket)	

Hoisting Information



Failure to lift the collector correctly can result in severe personal injury or property damage.

Do not lift unit by the door handle.

Use appropriate lifting equipment and adopt all safety precautions needed for moving and handling the equipment.

A crane or forklift is recommended for unloading, assembly, and installation of the collector.

Location must be clear of all obstructions, such as utility lines or roof overhang.

Use all lifting points provided.

Use clevis connectors, not hooks, on lifting slings.

Use spreader bars to prevent damage to units casing.

Check the Specification Control drawing for weight and dimensions of the unit and components to ensure adequate crane capacity.

Allow only qualified crane operators to lift the equipment.

Refer to applicable OSHA regulations and local codes when using cranes, forklifts, and other lifting equipment.

Lift unit and accessories separately and assemble after unit is in place.

Use drift pins to align holes in section flanges during assembly.

Electrical Wiring



Electrical work must be performed by a qualified electrician and comply with all applicable national and local codes.

Turn power off and lock out electrical power sources before performing service or maintenance work.

Do not install in classified hazardous atmospheres without an enclosure rated for the application.

All electrical wiring and connections, including electrical grounding, should be made in accordance with the National Electric Code (NFPA No. 70-latest edition).

Check local ordinances for additional requirements that apply.

The appropriate wiring schematic and electrical rating must be used. See unit's rating plate for required voltage.

If the unit is not furnished with a factory-mounted disconnect, an electric disconnect switch having adequate amp capacity shall be installed in accordance with Part IX, Article 430 of the National Electrical Code (NFPA No. 70-latest edition). Check unit's rating plate for voltage and amperage ratings.

Refer to the wiring diagram for the number of wires required for main power wiring and remote wiring.

Standard Equipment

Dust Drawer Units

Standard equipment consists of a self-contained unit housing the filters, blower, clean- and dirty-air chambers, and dust drawers. Locate the unit as close to the dust source as possible, except where explosive or flammable material exists.

Hopper and Leg Installation

1. Prepare foundation in the selected location. Install anchor bolts to extend a minimum of 1 3/4-in above foundation.
2. Lift the hopper using a crane.
3. Stand each leg on its pad in position under hopper.
4. Use drift pins to align holes in the hopper with the holes in the legs.
5. Secure legs to hopper using bolts, washers, and nuts provided. Do not tighten hardware at this time. Do not remove crane.
6. Position and bolt the cross brace in place using the hardware provided. Do not tighten hardware.
7. Bolt inside and outside cross braces together where they form a X. Do not tighten hardware.
8. Lift the hopper and leg assembly and lower slowly to the anchor bolts.
9. Level the hopper at the top flange using steel shims if necessary. Secure leg pads to anchor bolts with the appropriate customer-supplied washers and nuts.
10. Tighten all hardware on the legs, cross braces, and anchor bolts. Recheck level and adjust as necessary.
11. Remove crane.

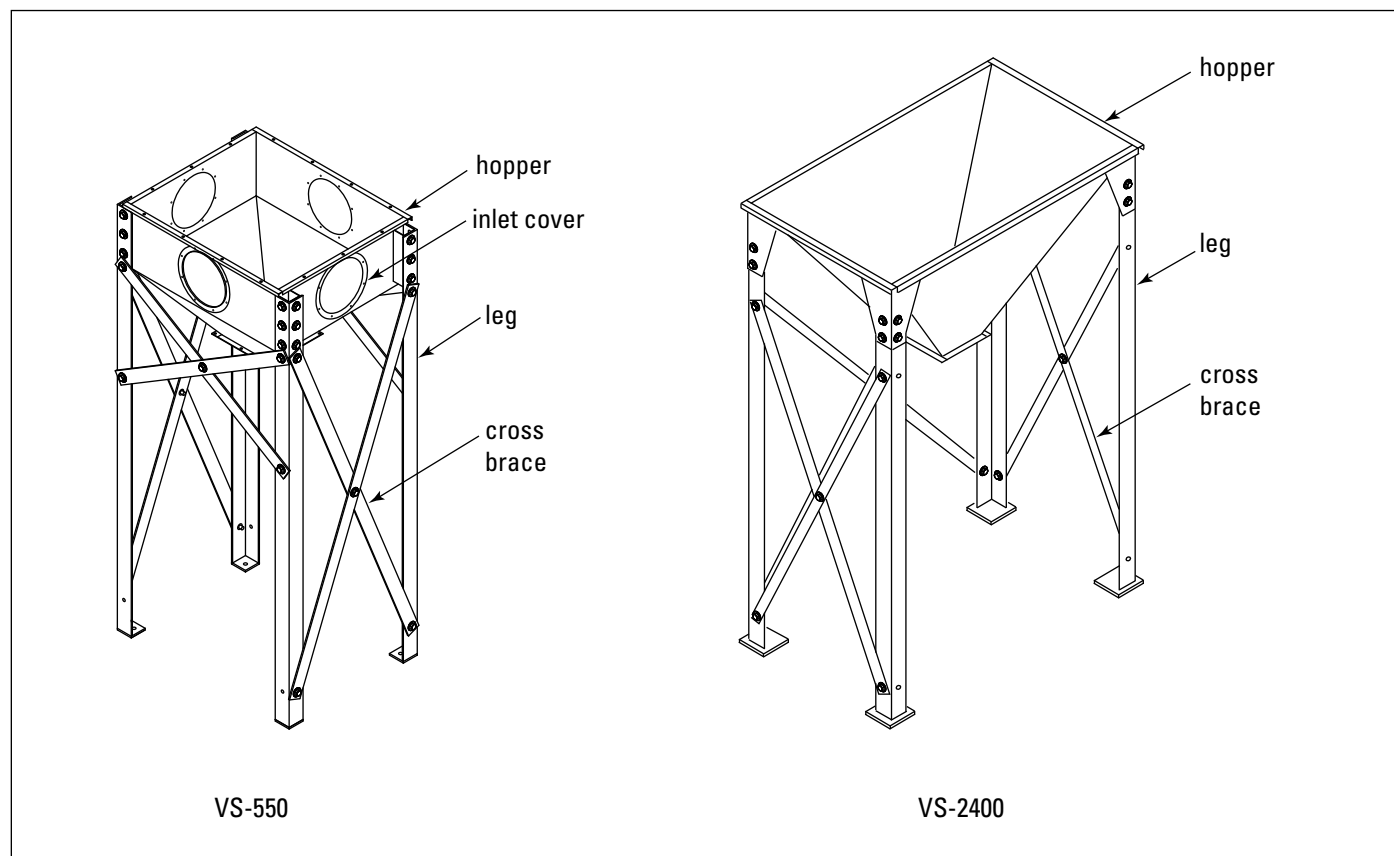

Hopper and Leg Installation

Cabinet Assembly

1. Place 1/4-in diameter, rope-type sealant around the hopper's top flange toward the outside of the bolt pattern.
2. Lift the cabinet into position over the leg and hopper assembly and lower slowly.

Note: Access the lifting lugs on VS-2400 and VS-3000 by removing the top cover panel. Lifting lugs are located on the blower support panel.

3. Align the holes in the hopper flange with the holes in the cabinet and secure using the hardware supplied.

Note: Inlet collars can be located on any side of the VS-500, -1200, or -1500 hopper by removing the cover plate.

Ductwork

Locate the unit to ensure the shortest duct lengths.

Elbow radius should be two times the duct diameter.

Maximum 30° branch entries.

Avoid using tees.

Connect duct joints with sheet metal screws, rivets, or solder and finish with a single wrap of duct tape.

Size all ductwork for the air velocity recommended for the material conveyed.

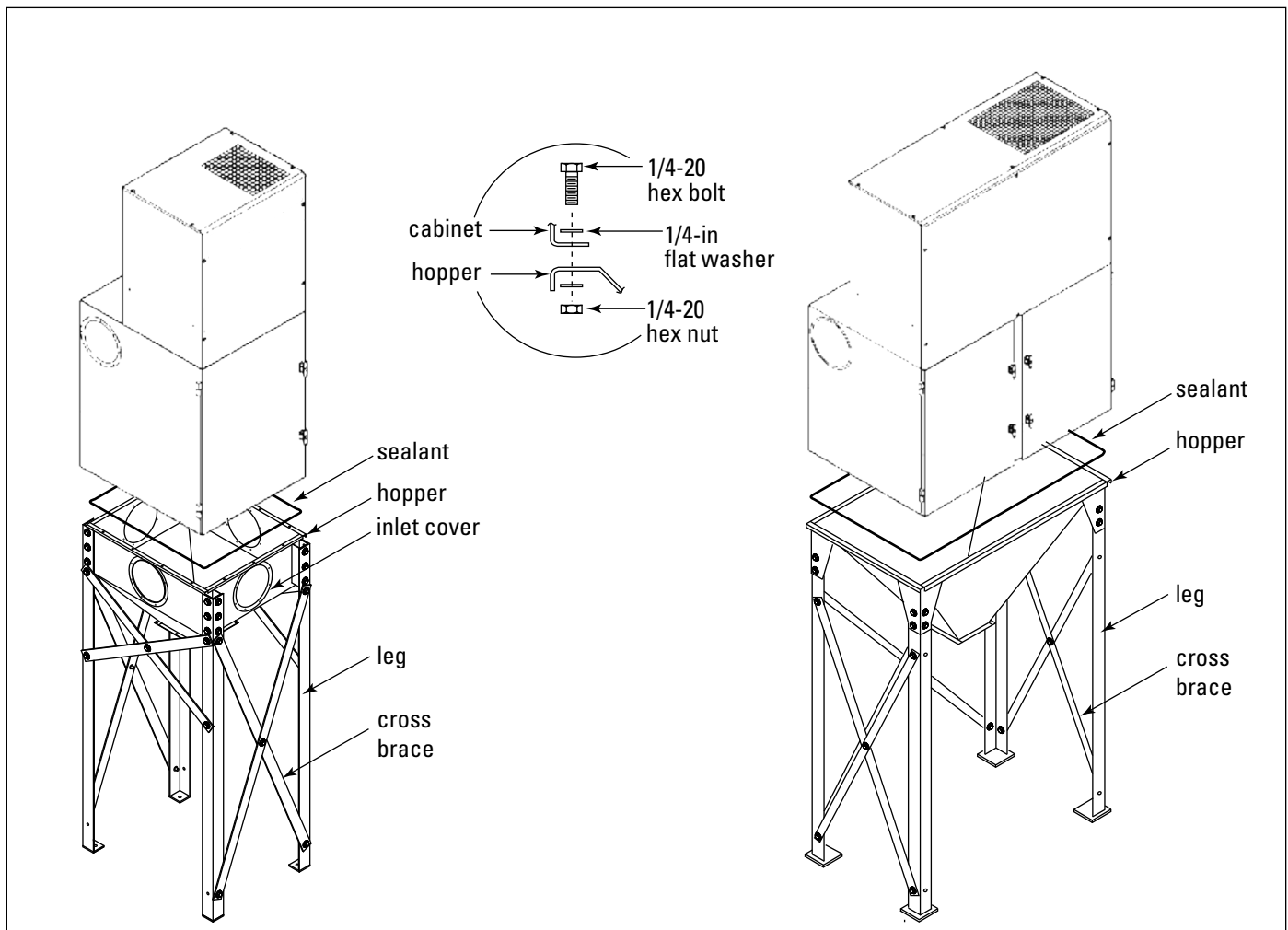

Cabinet Assembly

Electrical Connection



WARNING

Electrical work must be performed by a qualified electrician and comply with all applicable national and local codes.

Turn power off and lock out electrical power sources before performing service or maintenance work.

Do not install in classified hazardous atmospheres without an enclosure rated for the application.

1. Using the wiring diagram supplied, wire the customer-supplied disconnect switch and fan starter. Make the connections to the fan motor, and control box. Use appropriate wire gauge for rated amp load as specified by local codes.
2. Turn the fan motor ON then OFF to check for proper rotation by referencing the rotation arrow located on the motor's mounting plate.

To reverse rotation, three-phase power supply: Turn electrical power OFF at source and switch any two leads on the output-side of the fan-motor starter.



WARNING

Do not interchange a power lead with the ground wire. Severe damage or personal injury may result.

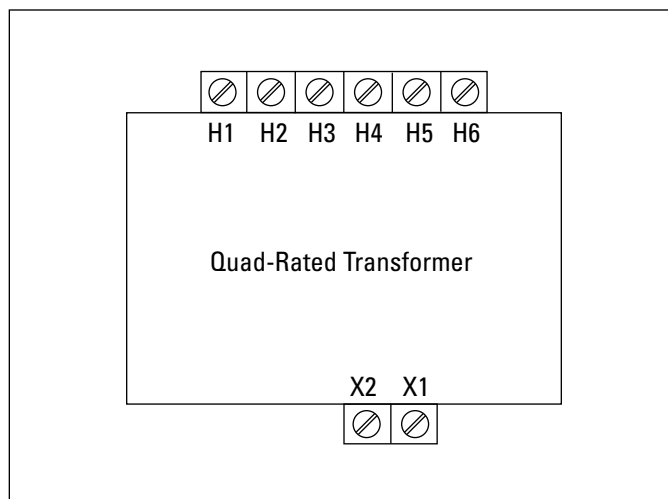

Quad-Rated Transformer

Input Voltage				
H1-H2	H1-H3	H1-H4	H1-H5	H1-H6
200	220	380	440	550
208	230	400	460	575
	240	415	480	600

Output Voltage

120-Volt Nominal

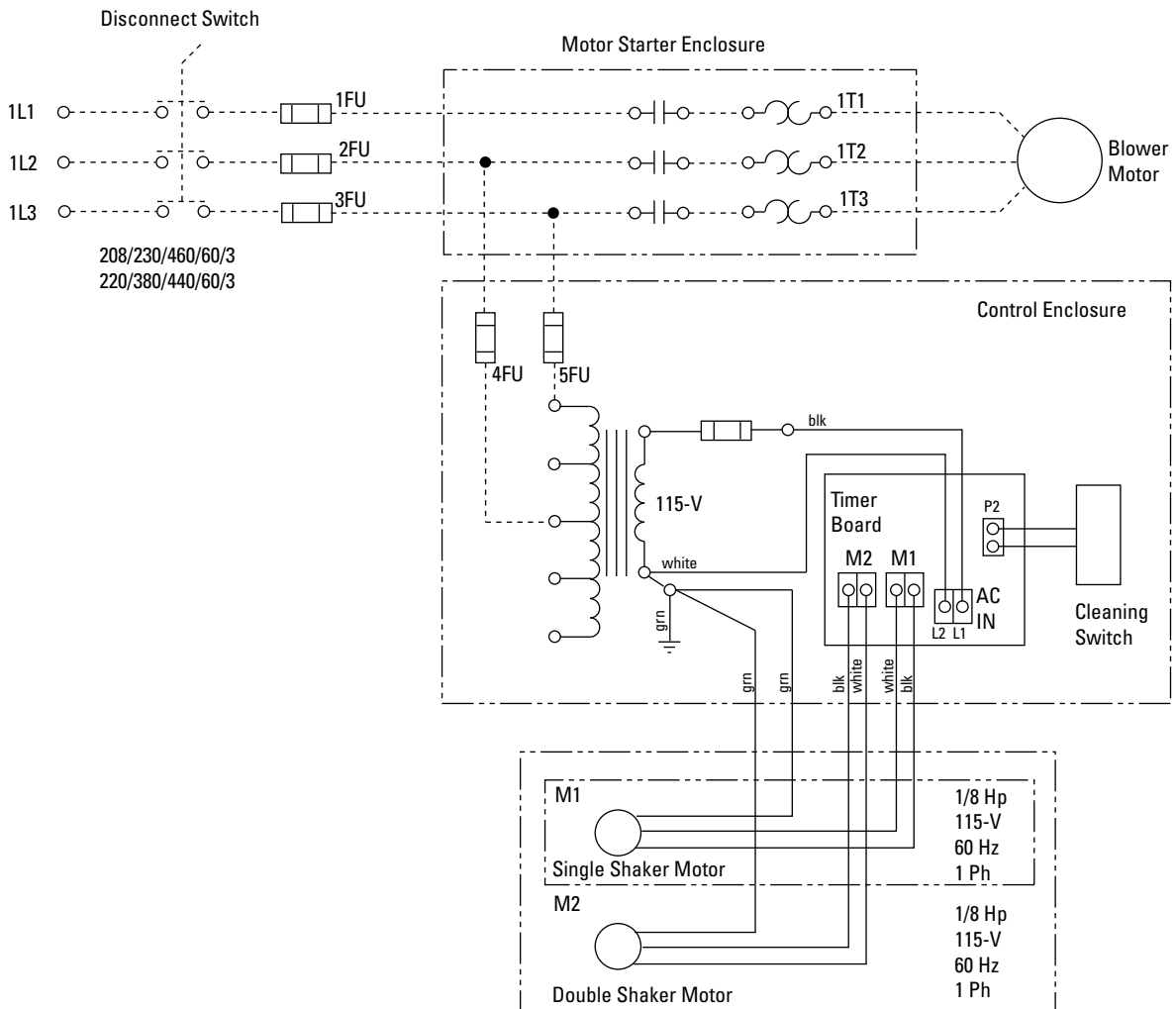

Cleaning Operation

1. Unit shutdown.
2. Rundown time: 60-second, single shaker motor; 180-second, double shaker motor.
3. 60-second cleaning cycle.
4. No time delay on start-up. If start-up is initiated during the cleaning operation, the shaker motor will turn OFF.

Timer Connection

- M1 White and black motor leads factory wired, single and double shaker motor.
 - M2 White and black motor leads factory wired. double shaker motor only
 - L1 Black 115-Volt line voltage IN, factory wired.
 - L2 White 115-Volt line voltage IN, factory wired.
- Note: In grounded systems, connect L2 to the transformer's 110-V neutral terminal.
- L3 Factory wired pressure switch.

Wiring Diagram

Preliminary Start-Up Check

Instruct all personnel on safe use and maintenance procedures.

WARNING

Electrical work during installation must be performed by a qualified electrician and comply with all applicable national and local codes.

Turn power off and lock out electrical power sources before performing service or maintenance work.

Check that the collector is clear and free of all debris before starting.

Do not install in classified hazardous atmospheres without an enclosure rated for the application.

Optional fans over 600 lbs must be independently supported.

1. Check all electrical connections for tightness and contact.
2. Motor and fan should be wired for clockwise rotation when viewed from the back of the motor.

To reverse rotation, three-phase power supply:
Turn electrical power OFF at source and switch any two leads on the motor junction box.

WARNING

Do not interchange a power lead with the ground wire. Severe damage or personal injury may result.

3. All access panels should be sealed and secure.
4. Check that the dust container is properly sealed and clamped.
5. Check and remove all loose items in or near the inlet and outlet of the unit.
6. Check that all remote controls and solenoid enclosures (if applicable) are properly wired and all service switches are in the OFF position.
7. Check that all optional accessories are installed properly and secured.

8. Turn power ON at source.
9. Turn blower fan motor ON.

WARNING

Do not look into fan outlet to determine rotation. View the fan rotation through the back of the motor.

Check that the exhaust plenum is free of tools or debris before checking blower/fan rotation.

Stand clear of exhaust to avoid personal injury.

Maintenance Information

Instruct all personnel on safe use and maintenance procedures.



WARNING Electrical service or maintenance work must be performed by a qualified electrician and comply with all applicable national and local codes.

Turn power off and lock out electrical power sources before performing service or maintenance work.

Do not install in classified hazardous atmospheres without an enclosure rated for the application.

Operational Checklist

1. Monitor the physical condition of the collector and repair or replace any damaged components.

Routine inspections will minimize downtime and maintain optimum system performance. This is particularly important on continuous-duty applications.

2. Monitor pressure drop across filters.

Abnormal changes in pressure drop indicate a change in operating conditions and possibly a fault to be corrected. For example, prolonged lack of compressed air will cause an excess build-up of dust on the filters resulting in increased pressure drop. Cleaning off-line with no flow usually restores the filters to normal pressure drop.

3. Monitor exhaust.
4. Monitor dust disposal.

Filter Removal and Installation



WARNING Use proper safety and protective equipment when removing contaminants and filters.

Dirty filters may be heavier than they appear.

Use care when removing filters to avoid personal injury.

Prefilter Removal

1. Remove the nylon mesh prefilter.
2. Reinstall the prefilter placing the top edge against the upper end cap of the filter cartridge. Stretch the screen for a tight fit and secure using a hook-and-loop fastener.

Note: The prefilter must cover all holes in the perforated liner. Stretch to fit.

Filter Cartridge Removal

1. Disconnect electrical power.
2. Open the bottom access door.
3. Loosen four filter support knobs.
4. Turn the retaining ring counterclockwise to release the ring and filter.
5. Remove the retaining ring and filter and dispose of filter properly.

Filter Installation

1. Check the gasket surface on the shaker panel and clean as necessary.
2. Install new filter reusing the retaining ring and tighten the four filter support knobs by hand.
3. Check the door gasket for condition and replace as necessary.
4. Close bottom access door and secure latches.

Note: Slight bleed-through on new filters is normal and will disappear as the filter seasons.

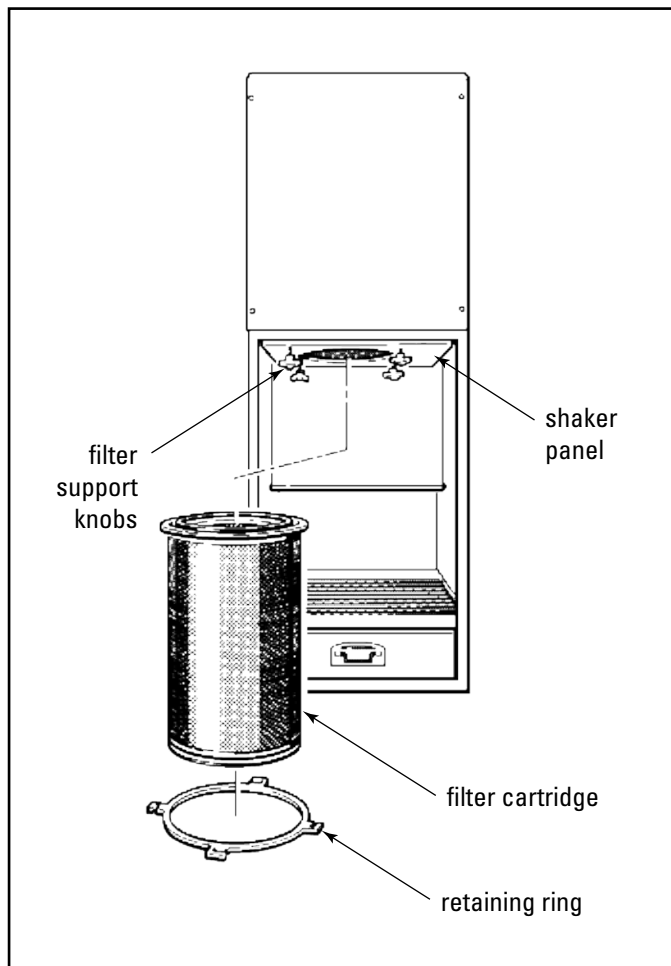

Filter Cartridge Installation

Dust Disposal

1. Turn unit OFF and empty dust container as necessary to minimize dust in the hopper.
2. If the optional 5- or 55-gallon drum attachment is used, empty when drum is $\frac{2}{3}$ full.
3. If optional slide gate is used, close gate before servicing drum.
4. Reinstall drum and open gate.

Optional Equipment

55-Gallon Drum Pack

The drum pack is designed to fit a customer-supplied, standard 55-gallon drum and provides easy access for dust removal and disposal. A flexible hose connects the drum cover hopper. Placing a pallet under the drum allows heavier materials to be moved quickly using a forklift or pallet jack. If a pallet is used, the length of flexible hose may need to be shortened.

1. Place 1/4-in diameter, rope-type sealant between the hopper flange and the drum cover mounting flange toward the inside edge of the bolt pattern.
2. Fasten using the bolts, washers, and nuts supplied.
3. Attach the drum cover to the 55-gallon drum.
4. Use latches to secure the cover to the drum, if equipped.

5-Gallon Pail Pack

1. Apply sealant to the hopper flange or the pail cover mounting plate flange toward the inside edge of the bolt pattern.
2. Fasten the pail pack to the hopper using the bolts, washers, and nuts supplied.

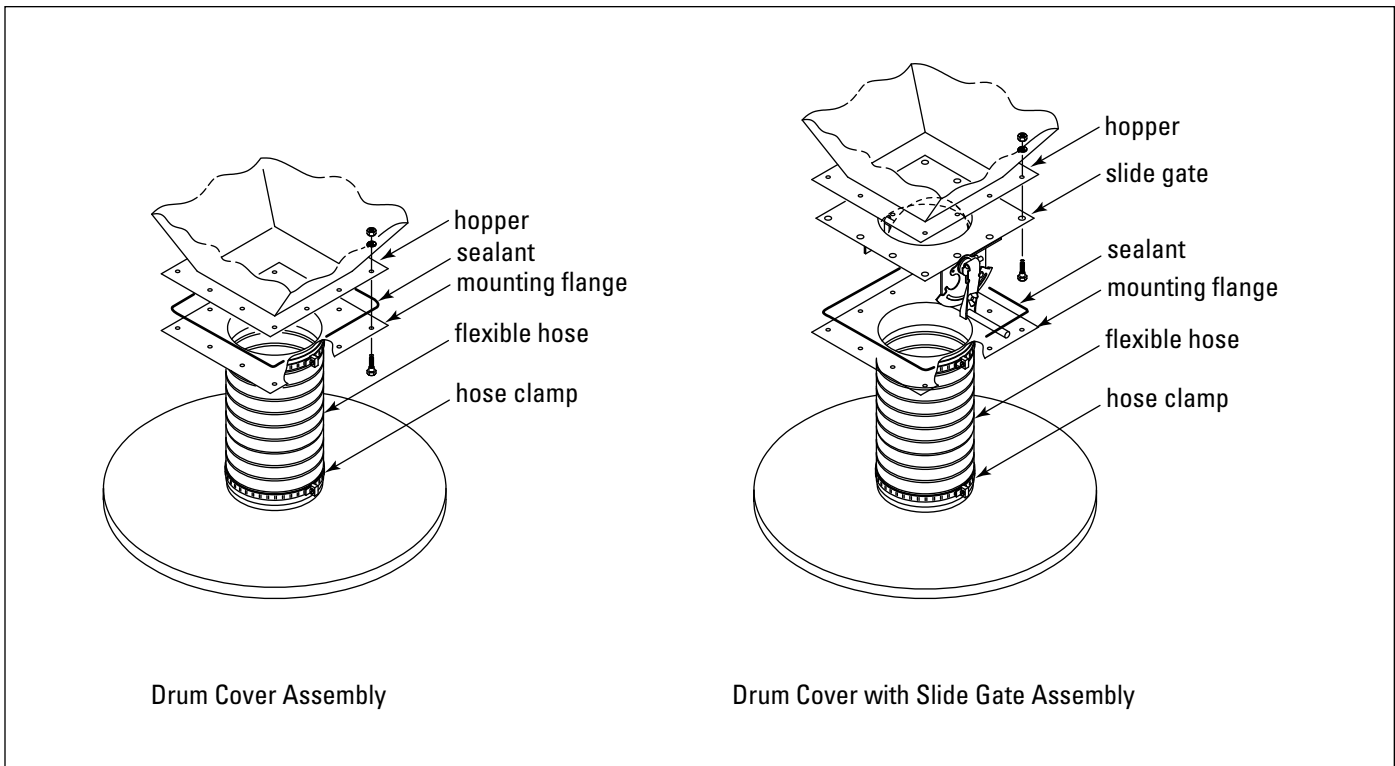

55-Gallon Drum Pack with and without Slide Gate

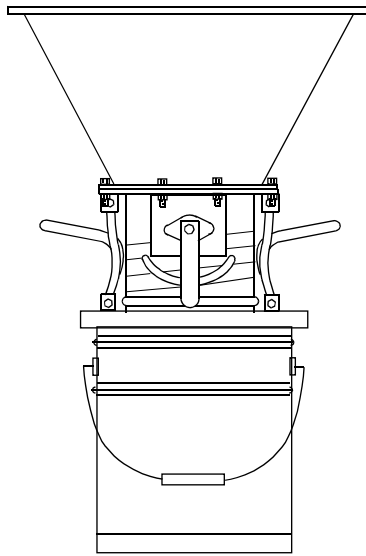

Pail Pack
with Gate Valve

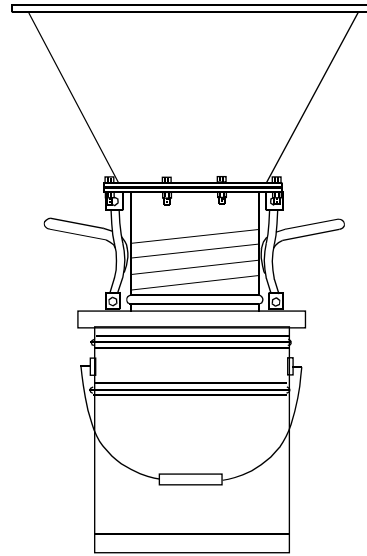

Pail Pack
without Gate Valve

5-Gallon Pail Pack with and without Slide Gate

Control Box

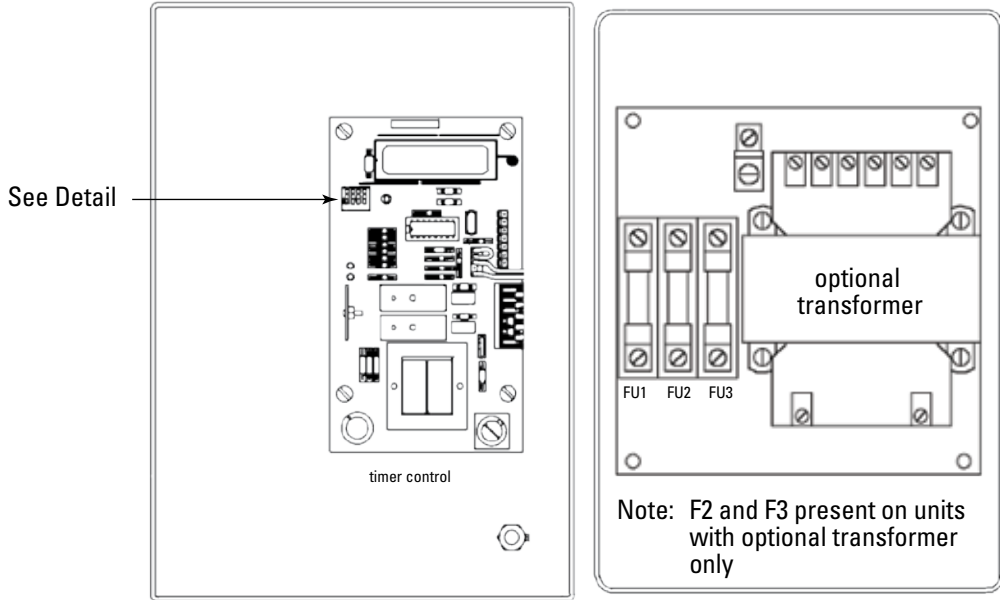

Control Box Assembly

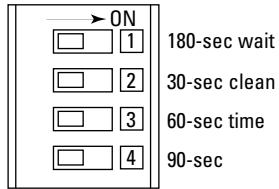

Single VS-550, 1200, and 1500
Switches preset to OFF position.
Default set to 60-sec wait, 60-sec clean.

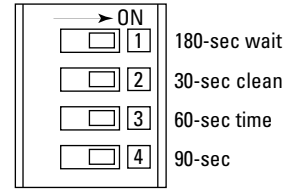

Double VS-2400 and 3000
Switch 1 to ON position.
Set to 180-sec wait, default 60-sec clean.

Control Box Assembly

Shaker Assembly

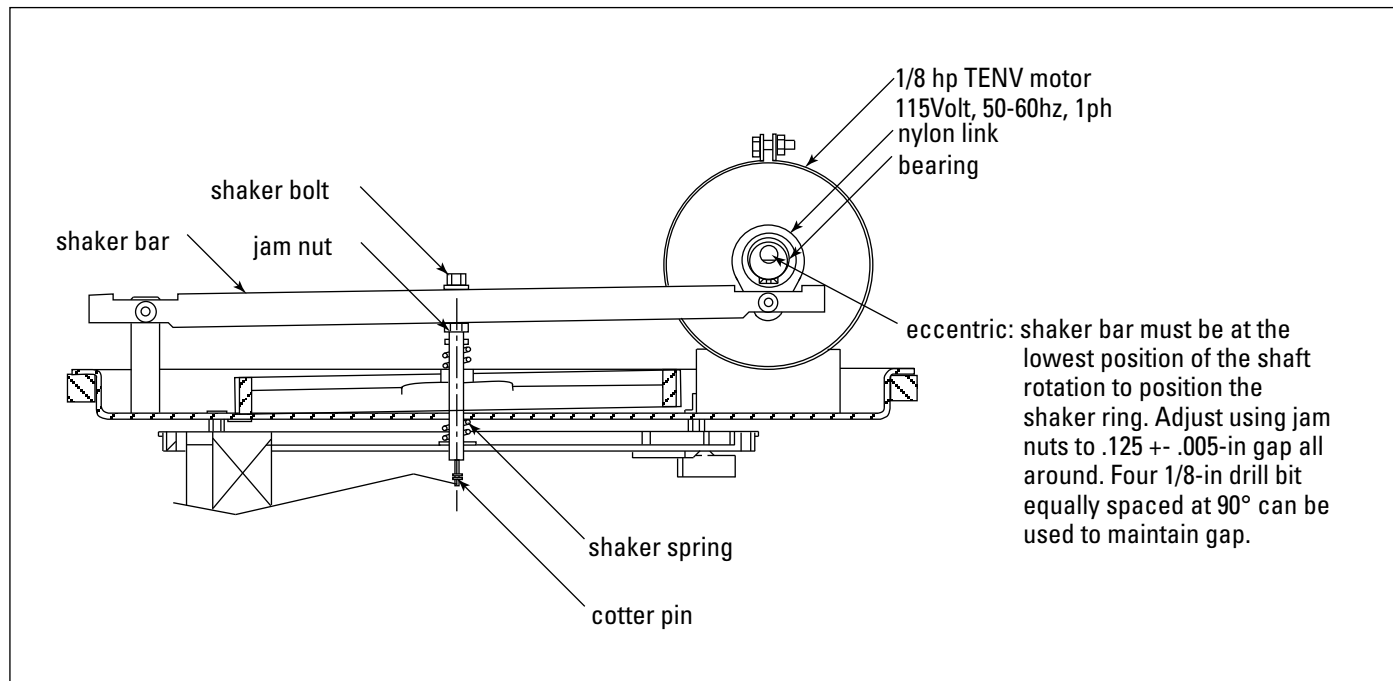

Single and Double Shaker Assembly

Pressure Switch Connection

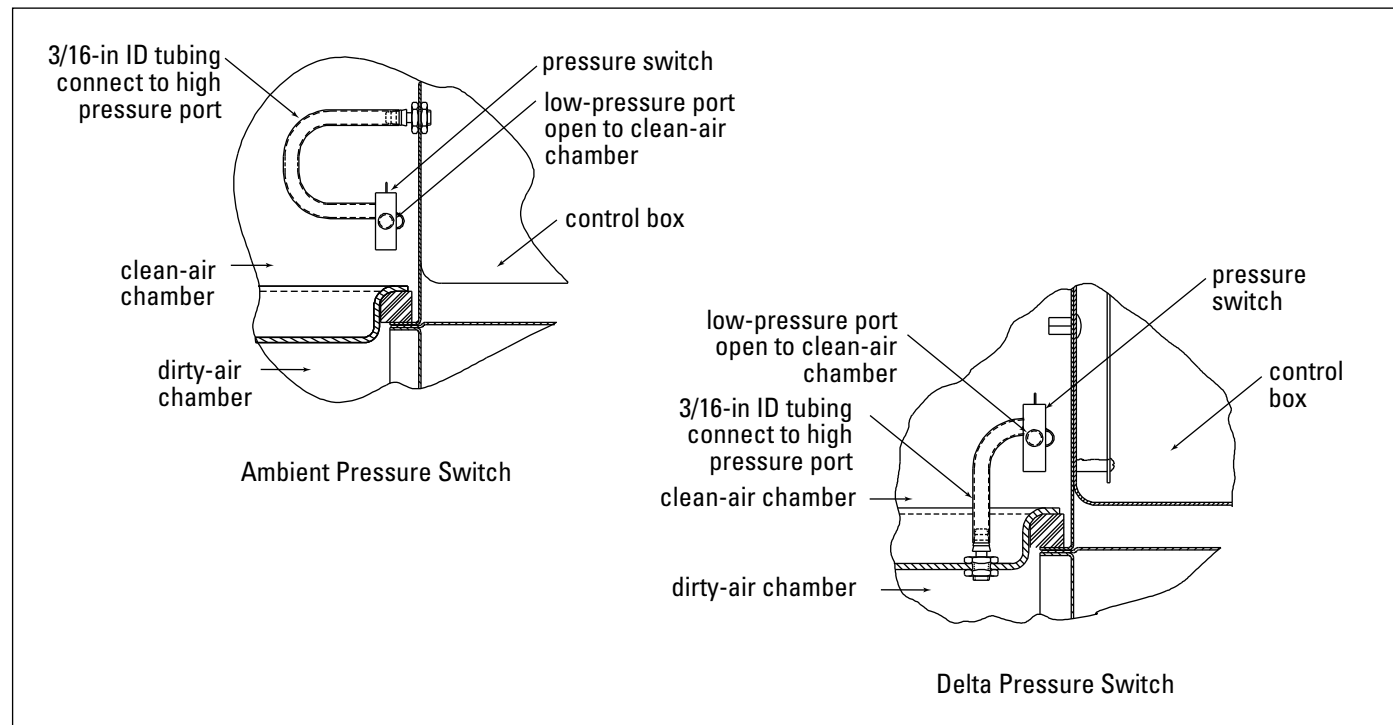

Pressure Switch Connection

Troubleshooting

Problem	Probable Cause	Remedy
Blower fan and motor do not start	Improper motor wire size	Rewire using the correct wire gauge as specified by national and local codes.
	Not wired correctly	Check and correct motor wiring for supply voltage. See motor manufacturer's wiring diagram. Follow wiring diagram and the National Electric Code.
	Unit not wired for available voltage	Correct wiring for proper supply voltage.
	Input circuit down	Check power supply to motor circuit on all leads.
	Electrical supply circuit down	Check power supply circuit for proper voltage. Check for fuse or circuit breaker fault. Replace as necessary.
Blower fan and motor start, but do not stay running	Incorrect motor starter installed	Check for proper motor starter and replace if necessary.
	Access doors are open or not closed tight	Close and tighten access doors. See Filter Replacement.
	Electrical circuit overload	Check that the power supply circuit has sufficient power to run all equipment.
	Inlet too large.	Contact Donaldson Torit for assistance.
Insufficient airflow	Fan rotation backwards	Proper fan rotation is clockwise from the top of the unit. The fan can be viewed through the back of the motor. See Preliminary Start-Up Check.
	Access doors open or not closed tight	Check that all access doors are in place and secured. Check that the hopper discharge opening is sealed and that dust container is installed correctly.
	Fan exhaust area restricted	Check fan exhaust area for obstructions. Remove material or debris. Adjust damper flow control.
	Collapsed or obstructed ductwork	Remove and clean duct. Replace collapsed duct.
	Improper duct size or too much flexible duct	Contact Donaldson Torit for assistance.
	Dust storage area overfilled or plugged	Clean out dust storage area. See Dust Disposal.
	Nylon mesh prefilter plugged or not in place	Remove the nylon mesh filter. See Filter Removal and Installation.
	Shaker ring not gapped correctly	Check and reset the shaker ring gap. See Shaker Assembly illustration.
	Shaker arm restricted	Disconnect the shaker bar and check the nylon link and bearing - it should pivot in the shaker channel easily. With the shaker bar disconnected, allow the shaker motor to run and check the amp draw. If over 2.5 amps, replace the shaker motor.

Problem	Probable Cause	Remedy
Control board indicator light not flashing	No input voltage to transformer	Check and correct voltage at the transformer's primary and secondary terminal. See Electrical Connection.
	No output voltage from transformer	Replace transformer fuse with identical fuse only. Other types may cause shaker motor damage.
	Faulty transformer	Check for 115 to 120-Volts at the transformer's secondary terminals. Replace transformer if no output voltage is present.
Control board indicator light flashing, but shaker motor does not start	Transformer not wired correctly.	Correct transformer wiring.
	Shaker motor not wired correctly	See Electrical Connection.
	Faulty shaker motor	Replace shaker motor.
	Pressure switch tubing not installed correctly	Check tubing connection and condition. Do not kink or pinch tubing. Note: The main blower fan must be ON for a minimum of 30-seconds for the timing sequence to start.
	Check pressure switch adjustment (if adjustable)	Turn screw clockwise until it stops and back out approximately three turns counterclockwise.
Faulty pressure switch	With power to the timer board ON, remove the two wires from the pressure switch. Using a small wire, jumper across the end of the two white wires and maintain contact for at least 30-seconds. Remove the jumper wire and wait 60-seconds for VS-550, 1200, and 1500 or 180-seconds for VS-2400 and 3000. If the shaker motor starts, replace the pressure switch.	
Control board flashing light stops	Primary or secondary transformer fuse blown	Replace transformer fuse with identical fuse only. Other types may cause shaker motor damage.
	Timer board fuse blown	Replace with Littlefuse™ 3-amp, 3AG 125 VAC MDX Slow Blo only.
	Shaker mechanism malfunctioning	Disconnect the black and white wires from the shaker motor M1/J3 circuit on the control board. Connect the shaker motor to 115-Volt power from a separate source and check amp draw. If over 2.5 amps, replace the shaker motor. See Electrical Connection, Control Box and Shaker Assembly.

The Donaldson Torit Warranty

Donaldson warrants to the original purchaser that the major structural components of the goods will be free from defects in materials and workmanship for ten (10) years from the date of shipment, if properly installed, maintained and operated under normal conditions. Donaldson warrants all other Donaldson built components and accessories including Donaldson Airlocks, TBI Fans, TRB Fans, Fume Collector products, Donaldson built electrical control components and Donaldson built Afterfilter housings for twelve (12) months from date of shipment. Donaldson warrants Donaldson built filter elements to be free from defects in materials and workmanship for eighteen (18) months from date of shipment. Donaldson does not warrant against damages due to corrosion, abrasion, normal wear and tear, product modification, or product misapplication. Donaldson also makes no warranty whatsoever as to any goods manufactured or supplied by others including electric motors, fans and control components. After Donaldson has been given adequate opportunity to remedy any defects in material or workmanship, Donaldson retains the sole option to accept return of the goods, with freight paid by the purchaser, and to refund the purchase price for the goods after confirming the goods are returned undamaged and in usable condition. Such a refund will be in the full extent of Donaldson's liability. Donaldson shall not be liable for any other costs, expenses or damages whether direct, indirect, special, incidental, consequential or otherwise. The terms of this warranty may be modified only by a special warranty document signed by a Director, General Manager or Vice President of Donaldson. Failure to use genuine Donaldson replacement parts may void this warranty. THERE EXIST NO OTHER REPRESENTATIONS, WARRANTIES OR GUARANTEES EXCEPT AS STATED IN THIS PARAGRAPH AND ALL OTHER WARRANTIES INCLUDING MERCHANTABILITY AND FITNESS FOR A PARTICULAR PURPOSE, WHETHER EXPRESS OR IMPLIED ARE HEREBY EXPRESSLY EXCLUDED AND DISCLAIMED.



Donaldson
FILTRATION SOLUTIONS

Parts and Service

For genuine Donaldson replacement filters and parts, call the Parts Express Line. For faster service, have unit's model and serial number, quantity, part number, and description available.

Donaldson Company, Inc.
Torit
PO Box 1299
Minneapolis, MN 55440-1299
U.S.A.

800-365-1331 USA
800-343-3639 within Mexico

donaldsonorit@donaldson.com
donaldsonorit.com

Donaldson Company, Inc. is the leading designer and manufacturer of dust, mist, and fume collection equipment used to control industrial-air pollutants. Our equipment is designed to help reduce occupational hazards, lengthen machine life, reduce in-plant maintenance requirements, and improve product quality.

© 2002 Donaldson Company, Inc.
Printed in USA

IOM 4077700, Revision 9
October 2010