

Installation and Operation Manual

RF Baghouse Dust Collector Models RFWP and RFWPH



Throughout this manual statements indicating precautions necessary to *avoid equipment failure* are referenced in a **Note**. Statements indicating potential hazards that could result in *personal injury or property damage* are referenced in a **CAUTION!** box.

Illustrations are for reference only as actual product may vary.

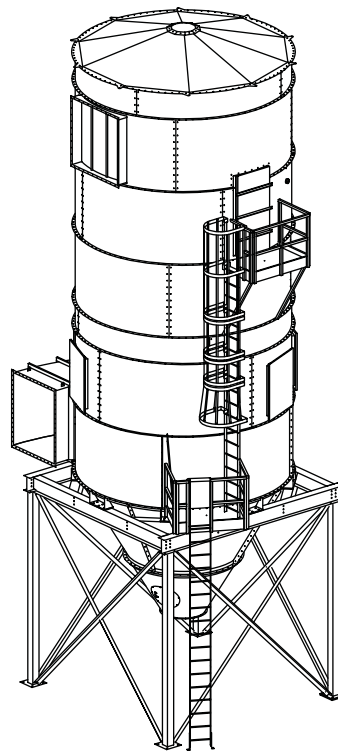

Model RFWP

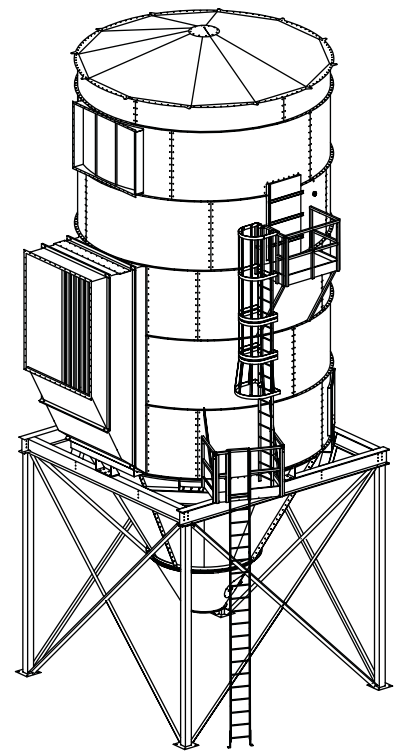

Model RFWPH

This manual is property of the owner. Leave with the unit when set-up and start-up are complete. Donaldson Company reserves the right to change design and specifications without prior notice.



CAUTION!

Application of Dust Control Equipment

- Combustible materials such as buffing lint, paper, wood, grain, coal, aluminum or steel dust, weld fume, or flammable solvents represent fire or explosion hazards. Use special care when selecting and operating all dust or fume collection equipment when combustible materials are present to protect workers and property from damage due to fire and/or explosion. Consult and comply with National and Local Codes relating to fire or explosion and all other appropriate codes when determining the location and operation of dust or fume collection equipment.
- When combustible materials are present, consult with an installer of fire extinguishing systems familiar with these types of fire hazards and local fire codes for recommendations and installation of fire extinguishing and explosion protection systems. Donaldson Torit dust collection equipment is not equipped with fire extinguishing or explosion protection systems.
- DO NOT allow sparks, cigarettes or other burning objects to enter the hood or duct of any dust or fume control equipment as these may initiate a fire or explosion.
- For optimum collector performance, use only Donaldson Torit replacement parts.

Contents

Data Sheet	3	Preliminary Start-Up Check	18
Description	4	Start-Up	19
Purpose and Intended Use	4	Start-UP/Shut-Down Sequence	19
RFWP Involute Operation	5	Start-Up Sequence	19
RFWPH High Inlet Operation	6	Shut-Down Sequence	19
Inspection on Arrival	7	Service Information	20
Installation Codes and Procedures	7	Operational Checklist	20
Installation	8	Maintenance	20
Site Selection, Grade-Mounted Units	8	Troubleshooting	21
Unit Location	8	Warranty	24
Electrical Wiring	9		
Hardware Requirements	9		
Cleaning System Operation	10		
Cleaning Mechanism	10		
Air Supply	12		
Solid-State Timer Installation	13		
Filter Bag Installation	16		
Boltsafe™	16		
Snap-In	16		



This manual contains specific precautionary statements relative to worker safety. Read thoroughly and comply as directed. Discuss the use and application of this equipment with a DonaldsonTorit representative. Instruct all personnel on safe use and maintenance procedures.

Data Sheet

Model Number _____	Serial Number _____
Ship Date _____	Installation Date _____
Customer Name _____	
Address _____	

Filter Type _____	
Accessories _____	
Other _____	

Description

The RF Baghouse is a continuous duty dust collector with bag-style filters designed to handle up to 141,000 cfm depending on the application and dust type. Continuous-duty means no downtime. The filters are pulse-cleaned without turning the unit off. A cleaning-cycle timer energizes the cleaning cycle that cleans each bag at least once every four minutes.

The cylindrical units feature a sectional bolt together design. Standard sizes range from 570 to 905 filter bags (either 10 or 12-ft long) and feature an involute, scroll-type inlet with an internal deflection baffle or a high body inlet. The involute inlet removes heavy materials before they reach the bags, eliminating the need for a separate cyclone precleaner. The high body inlet is for abrasive dust and offers better abrasion resistance.

The RF features a walk-in clean-air plenum, allowing filter bag service from inside the clean air plenum.

Purpose and Intended Use

The RF Baghouse collector is most commonly applied in high-volume, high dust-load applications including woodworking, grain, cement, chemical, coal, and food processing applications (especially sugar and other moisture-sensitive materials).

These RFs are most commonly used in applications over 37,000 cfm.

Sizes are available for applications with any of the following conditions or requirements:

- Heavy dust load
- No compressed air available
- A round unit required for sanitary reasons
- High pressure or vacuum requirement
- A requirement for a single discharge hopper

Operations involving high temperature and humidity may require special attention due to air temperature, material moisture content, and any material chemistry issues which may exist. Custom design modifications to the collector may be required for these applications.



CAUTION!

- Misuse or modification of this equipment may result in personal injury.
- Do not misuse or modify.

RFWP Involute Operation

During normal operation, dust-laden air enters the dirty-air inlet. The scroll-style involute inlet develops a cyclonic airflow causing heavier particulate to drop directly into the hopper. The air continues through an internal flow straightener that evenly distributes the dust-laden air within the

collector cross-section and around the filter bags. Dust is collected on the outside surface of each filter bag forming a filter dust cake. Clean, filtered air then passes through the filter bags, into the clean-air plenum, and discharges through the clean-air outlet.

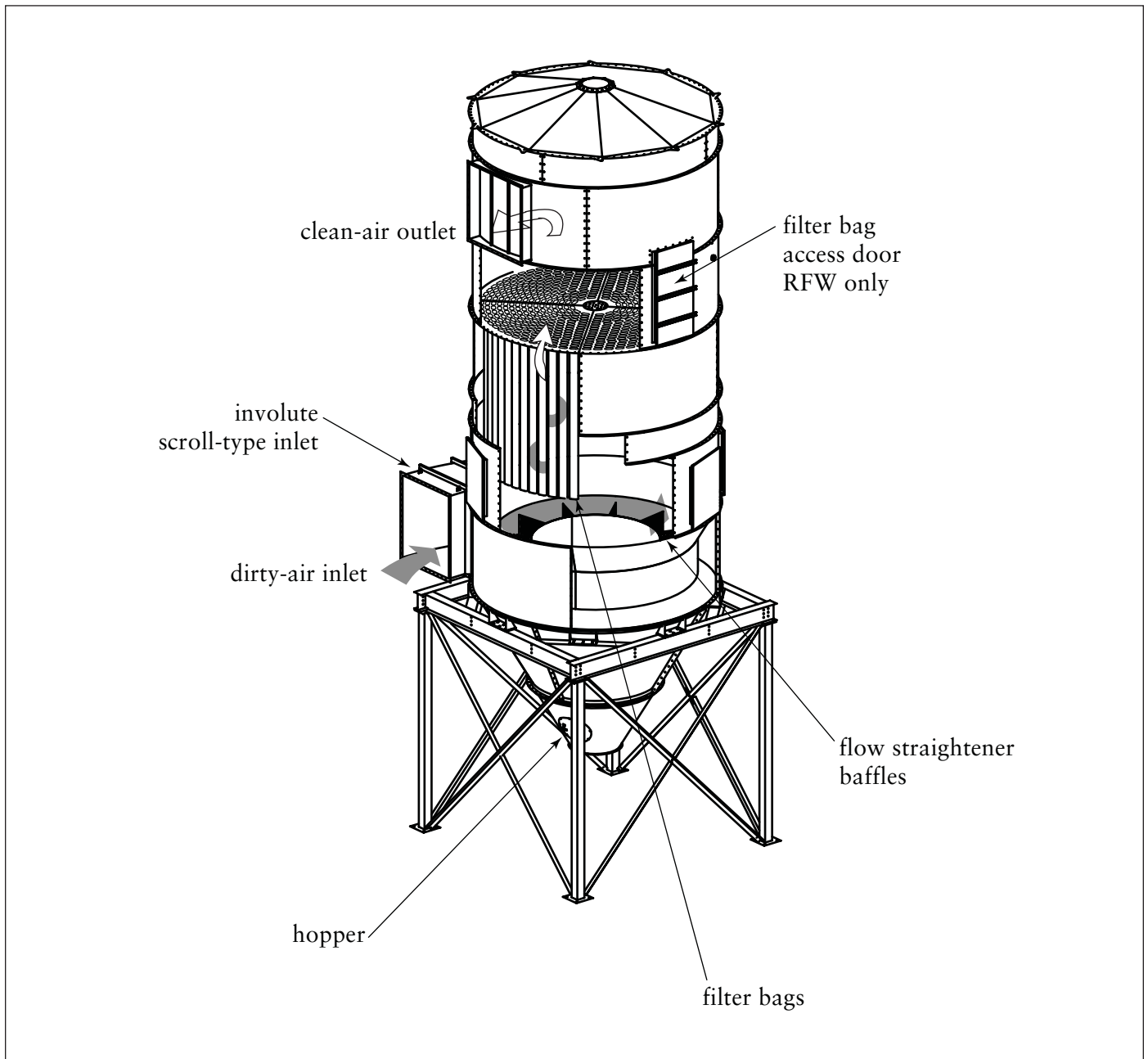

Involute Operation

RFWPH High Inlet Operation

High body inlets are necessary for certain applications including those with highly abrasive materials. In these cases as the air enters the dirty air plenum and passes through a set of self-sacrificing air distribution baffles that reduce the inertia of the abrasive materials causing much of

the dust to fall out of the air stream and into the hopper. The baffles are designed out of 3/16 thick steel offering long-term abrasion resistance. When a baffle section needs to be changed out for a new one, an easy bolt-on/bolt-off access door is opened and the specific worn baffles can be replaced.

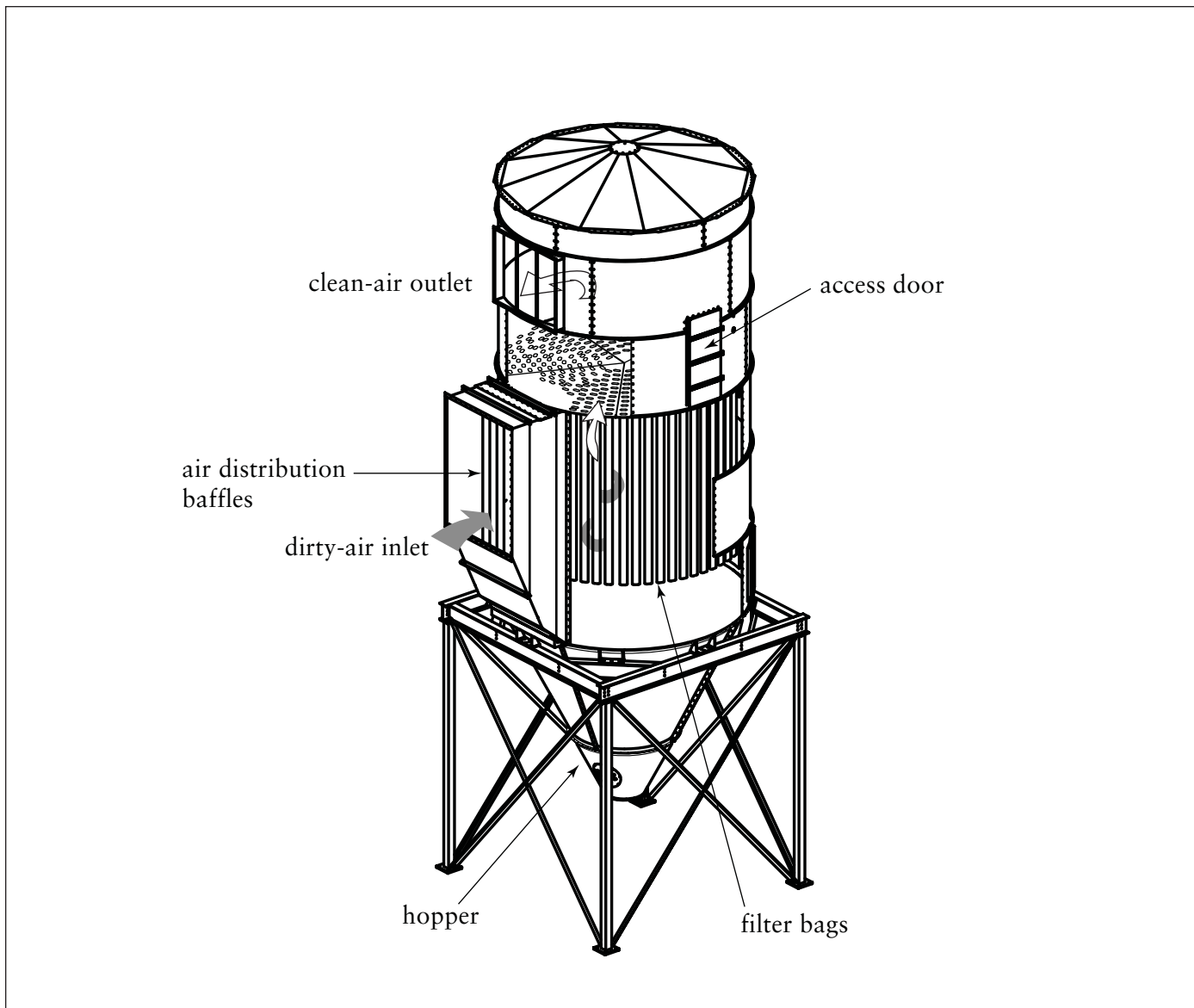

High Inlet Operation

Inspection on Arrival

1. Inspect unit on delivery.
2. Report any damage to the delivery carrier.
3. Request a written inspection report from the Claims Inspector to substantiate claim.
4. File claims with the delivery carrier.
5. Compare unit received with description of product ordered.
6. Report incomplete shipments to the delivery carrier and your Donaldson Torit representative.
7. Remove crates and shipping straps. Remove loose components and accessory packages before lifting unit from truck.
8. Any damaged components should not be used.

Installation Codes and Procedures



CAUTION!

OSHA may have requirements regarding recirculating filtered air in your facility. Consult with the appropriate local authorities to ensure compliance with all codes regarding recirculating filtered air.

1. Safe and efficient operation of the unit depends on proper installation.
2. Authorities with jurisdiction should be consulted before installing to verify local codes and installation procedures. In the absence of such codes, install unit according to the National Electric Code, NFPA No. 70-latest edition.
3. A qualified installation and service agent must complete installation and service of this equipment.
4. Use caution when unloading components. Do not damage components. Do not use damaged components.
5. Do not hang or mount external piping or unsupported accessory items.



CAUTION!

- Combustible materials such as buffing lint, paper, wood, grain, coal, aluminum or steel dust, coal, grain, weld fume, and flammable solvents represent fire or explosion hazards.
- Use special care when selecting and operating all collection equipment when combustible materials are present to protect workers and property from damage due to fire and/or explosion.
- Consult and comply with all national and local codes relating to fire or explosion, and all other appropriate codes when determining the location and operation of dust collection equipment.
- If sprinklers are installed, overflow drain devices are required. Properly size the overflow drains to match the flow rate output of the sprinkler taps.
- Donaldson Torit equipment is not equipped with fire extinguishing or explosion protection systems.
- Take precautions for grounding the collector. Contact Applications Engineering for special applications.
- Installation requires use of an overhead crane. Use proper equipment and protection. Protective gear should be worn to protect workers in case of falling components.

Installation

For full assembly details, see the Field Assembly Manual.

Site Selection, Grade-Mounted Units

1. The unit can be located on a reinforced concrete foundation or other structurally approved surface.
2. Wind, seismic zone, and other live-load conditions must be considered when selecting the location for structure mounted units.
3. Provide clearance from heat sources and interference with utilities when selecting the location.

Unit Location

1. When hazardous conditions or materials are present, consult with local authorities for the proper location of the collector.
2. The foundation or support structure must be sized to withstand all pertinent dead, live, snow and dust loads in addition to shear and overturning reactions from wind, seismic, and explosion venting forces. Remember to also consider all tributary piping and ductwork to the collector and possible water accumulation from a sprinkler system, if applicable.

3. A concrete foundation must be properly reinforced (with rebar, etc.) and of sufficient strength and thickness to withstand above loads. Make sure the foundation is poured at least 28 days in advance to develop full strength prior to setting the collector and epoxy anchor bolts, etc. Refer to the collector specification control drawing for anchor bolt type, size and embedment requirements. Make sure the anchor bolt length extends above the foundation sufficiently to allow for grouting, baseplate thickness and hardware requirements to secure the collector.
4. Locate the collector to ensure the shortest and straightest inlet- and outlet-duct length, easy access to electrical connections and routine maintenance.
5. Ensure placement site does not interfere with overhead wires, guy wires, or air traffic.



CAUTION!

- Combustible materials such as buffing lint, paper, wood, aluminum or steel dust, weld fume, and flammable solvents represent fire or explosion hazards.
- Use special care when selecting and operating all collection equipment when combustible materials are present to protect workers and property from damage due to fire and/or explosion.
- Consult and comply with all National and Local Codes relating to fire or explosion, and all other appropriate codes when determining the location and operation of dust collection equipment.
- Donaldson Torit equipment is not equipped with fire extinguishing or explosion protection systems unless specifically ordered.

Electrical Wiring



CAUTION!

- Electrical installation must be performed by a qualified electrician and comply with all applicable national and local codes.
- Lock out electrical power sources before performing service or maintenance work.
- Do not install in classified hazardous atmospheres without an enclosure rated for the application.
- Handling of electrical components may cause shock.

1. All electrical wiring and connections, including electrical grounding, should be made in accordance with the National Electric Code and NFPA No. 70-latest edition.
2. Check local ordinances for additional requirements that apply.
3. The appropriate wiring schematic and electrical rating must be used. See unit's rating plate for required voltage.
4. If the unit is not furnished with a factory-mounted disconnect, an electric disconnect switch having adequate amp capacity shall be installed in accordance with Part IX, Article 430 of the National Electrical Code and NFPA No. 70-latest edition. Check unit's rating plate for voltage and amperage ratings.
5. Refer to the wiring diagram for the number of wires required for main power wiring and remote wiring.

Hardware Requirements

Typical Hardware

Bolt, Grade 5
 2-Hardened Washers per ASTM F436
 Lock Washer
 Nut, Grade 5
 Flanged Nut, Case Hardened
 Flanged Bolt, Case Hardened

Hardware Size

Size	Assembly	Recommended Bolt Torque (ft/lbs)
3/8-in	Ladder Platform	37
1/2-in	Hopper Body(ies) Involute Inlet High Inlet Roof	90
5/8-in	Tube Sheet	180
3/4-in	Leg Structure	319

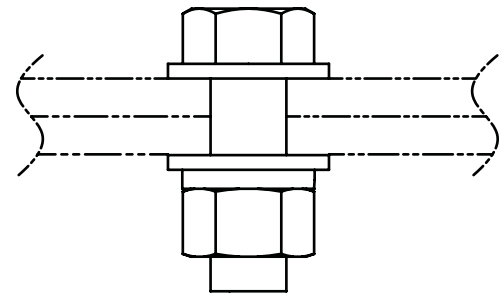

Grade 5 Hardware

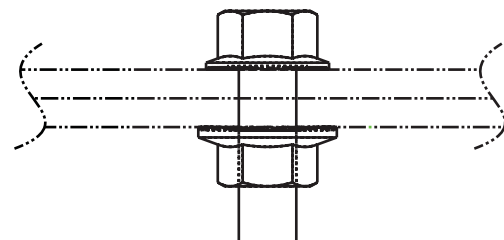

Flanged Hardware

Hardware

Cleaning System Operation

The RF cleaning system automatically cleans each bag at least once every four minutes. During the filter cleaning cycle, a solid-state timer is used to energize a solenoid valve and controls the open and close time of the diaphragm valve. An air reservoir stores the pressurized air. When the solenoid is activated, the diaphragm valve opens and a high-volume of pressurized air is directed through the manifold arms and into the filter bags dislodging the dust cake. The dislodged dust cake then falls into the hopper where it is discharged into a drum, rotary valve, screw conveyor, or pneumatic conveying system.

Cleaning Mechanism

1. Install the gear reducer drive motor. Check that the motor shaft key is in place and enters the keyway in the gear drive correctly. Fasten the motor flange to the gear reducer housing using four hex head cap screws supplied.
2. Fill the gearbox with lubricant according the instructions provided with the reducer. Remove the top pipe plug and install the breather.
3. Remove the plastic exhaust-port plug from the bottom of the solenoid valve.
4. Adjust the drive sprocket, tensioner sprocket and idler so they are in the same horizontal plane.

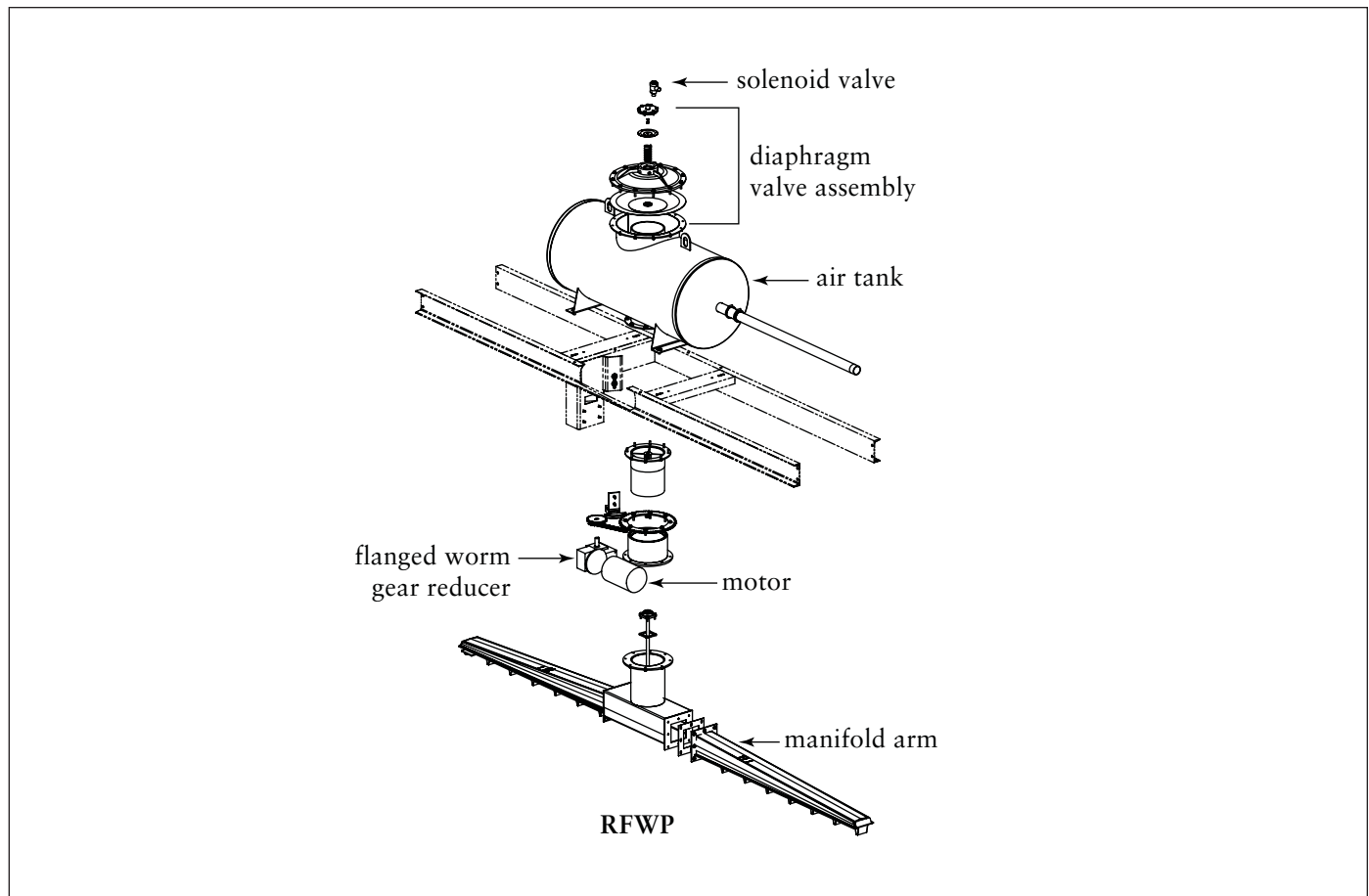

Cleaning Mechanism

5. Wire the motor to a customer-supplied motor starter with overload and short circuit protection.

Note: All electrical wiring and connections, including electrical grounding, must be made in accordance with the National Electric Code and NFPA No. 70-latest edition.

If the unit was supplied with an electrical control panel, the wiring diagram supplied with the control panel takes precedence over the general diagrams shown in this manual.

See Field Assembly Manual for full installation details.

Air Supply

A positive-displacement blower provides the air used for filter cleaning and is sized for each model's cleaning air requirements. Follow the installation instructions provided with the positive-displacement blower.

Note: Fill the gearbox with the lubricant supplied following the instructions provided with the positive-displacement blower. Lubricant may be temperature sensitive and need to be reviewed based on ambient conditions.

Turn the blower ON then OFF to check for proper rotation by referencing the rotation arrow located on the belt guard. Proper rotation is counterclockwise.

To reverse rotation, three-phase power supply:

Turn electrical power OFF at source and switch any two leads on the output-side of the blower motor starter.



CAUTION!

- Electrical installation must be performed by a qualified electrician and comply with all applicable national and local codes.
- Turn power off and lock out electrical power sources before performing installation, service, or maintenance work.
- Do not install in classified hazardous atmospheres without an enclosure rated for the application.

Air Supply Pipe Sizing	
Model	Pipe Diameter
570-905	2-in

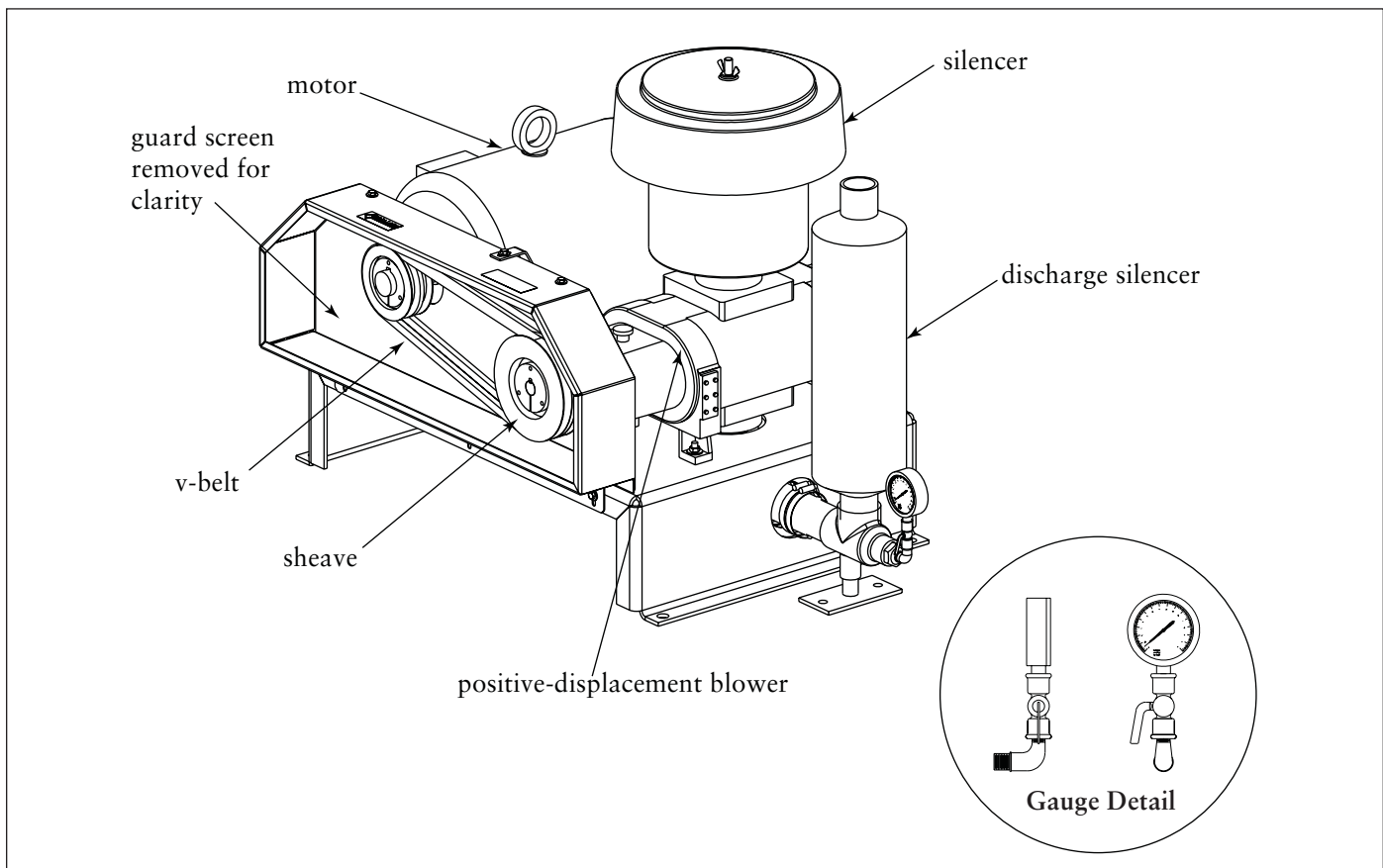

Positive-Displacement Blower Assembly

Solid-State Timer Installation

The solid-state timer is an electronic timer used to control the filter cleaning system.



CAUTION!

The solid-state timer requires a 105 to 135-Volt, customer-supplied power supply.

Note: Do not mount the solid-state timer on the unit or the positive-displacement blower as mechanical vibration can damage the control.

1. Mount the timer near the pressure gauge on the positive-displacement blower or air tank in a location convenient for accessibility and maintenance.
2. Using the wiring diagram supplied, wire the blower motor, blower-motor starter, solid-state timer, and solenoid valve. Use appropriate wire gauge for rated amp load as specified by the National Electric Code.



CAUTION!

- Electrical installation must be performed by a qualified electrician and comply with all applicable national and local codes.
- Turn power off and lock out electrical power sources before performing installation, service, or maintenance work.
- Do not install in classified hazardous atmospheres without an enclosure rated for the application.

Solenoid Connection

The unit is equipped with a 115-V solenoid valve that controls the diaphragm valve, which cleans the filters.

Wire the solenoid to the solid-state timer following the wiring diagram shown or the wiring diagram supplied with the unit. Filter life and cleaning operation will be adversely affected if not wired correctly.

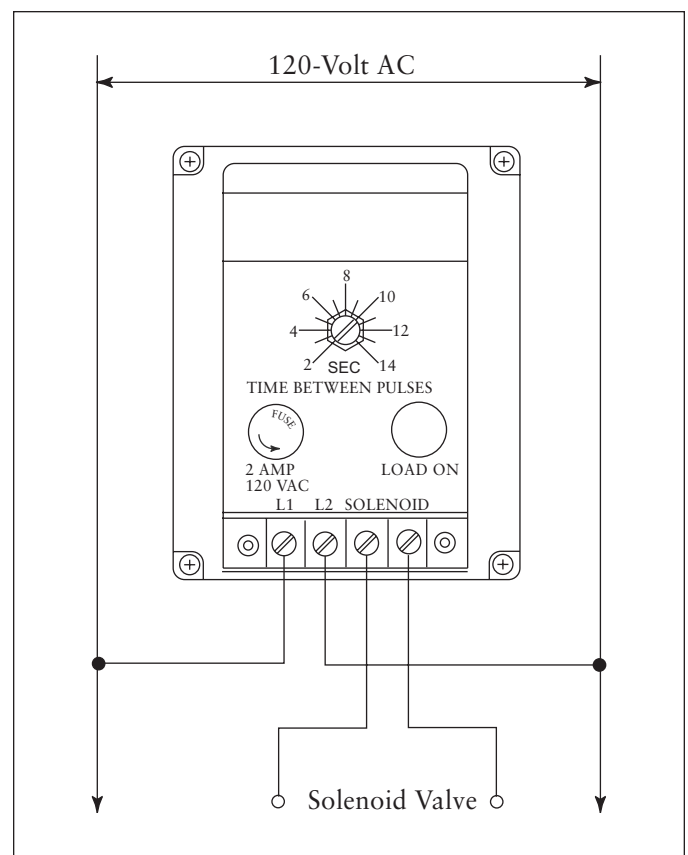

Timer Wiring

Timer and Solenoid Specifications

Note: If the unit was supplied with an electrical control panel, the wiring diagram supplied with the control panel should take precedence over the general diagrams shown in this manual.

Power to the solid-state timer is supplied to Terminals L1 and L2, which operate in parallel with the positive-displacement blower starter's low-voltage coil. On blower start-up, power is supplied to the timer and the preset OFF time is initiated. At the end of the OFF time, the timer energizes the solenoid valve to provide the ON time cleaning pulse for the diaphragm valve.

Input 105-135V/50-60Hz/1Ph

Output Solenoids The load is carried and turned ON and OFF by the 200 watt maximum load-per-output solid-state switch.

Pulse ON Time Factory set at 100-milliseconds, or 1/10-second. Pulse ON time is not adjustable.

Pulse OFF Time Factory set at 10-seconds; adjust the OFF time so that the pressure at the air reservoir peaks at 8 PSI for the 570-608 bag units and 9 PSI for everything larger just before the next pulse. Make final adjustments by observing the LOAD ON light flashing on the timer.

Note: Open the valve to the air reservoir gauge only when adjusting OFF time.

Operating Temperature Range -20° F to 130° F

Transient Voltage Protection 50 kW transient volts for 20-millisecond duration once every 20 seconds, 1% duty cycle.

Solenoid Valve 115-V at 19.7 watts

Interlocking

To insure proper operation of the system the main blower should not start unless the cleaning mechanism, positive-displacement blower, and dust removal system are all operating. Donaldson recommends the installation of an interlock device between these motors. Failure of the interlocked devices should generally not shut down the main blower, but should activate an alarm system, if available. A failure of either the discharge mechanism (rotary airlock or screw conveyor with separate drives) should typically shut down all other drives and alarm the operator. This will avoid filling the collector with dust.

Time Delay, Start-Up

Donaldson Torit recommends starting motors at 3-second intervals to minimize inrush current and to allow interlocking.

Time Delay, Shut-Down

Donaldson Torit recommends a sequenced shut down approach for optimal performance of the collector. After the main blower shuts down, the remaining components should continue to run for several minutes to empty the hopper and dust removal system of all dust that drops from the filter bags after the primary airflow stops.

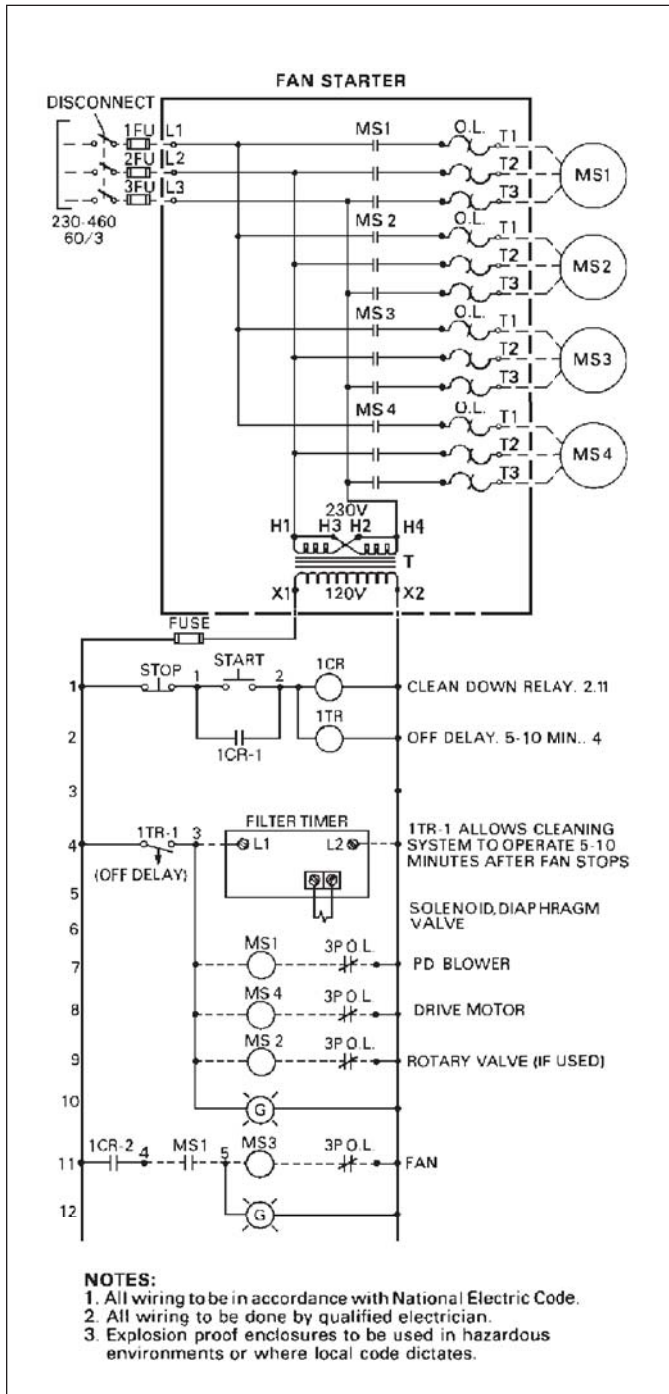

Unit Wiring

Filter Bag Installation



CAUTION!

- Turn power off and lock out electrical power sources before performing service or maintenance work.
- Turn air supply to collector OFF and depressurize the air tank before service or maintenance work is performed.

Snap-In

1. From the clean-air plenum, carefully insert the snap-in filter bag aligning the seam with the long edge of the oval in the tube sheet.
2. Snap the bag in place with the tube sheet between the upper and lower rings on the filter bag collar.
3. Slide the filter cage into the filter bag and seat firmly.

Boltsafe™

1. Slide the filter cage into filter bag until the top edge of the bag reaches the top flange of the filter cage.
Note: Place the bottom seam of the bag parallel to the long side of the oval, filter cage bottom.
2. From the clean-air plenum, carefully insert the filter and cage assembly through the tube sheet aligning the two bolts with the threaded inserts in the tube sheet.
3. Secure with Boltsafe bolts provided.

Note: Hand-start each bolt before tightening either bolt. Do not use a power or impact driver to tighten bolts. A speed wrench using maximum 20 ft/lb is recommended.



CAUTION!

- Filter bag removal may expose worker to the dust contaminant. Use protective measures appropriate for any concerns associated with the containment.
- Improper insertion of case and filter bag may result in a pinch point.

Note: To access bags under the cleaning manifold arm it is necessary to remove the chain on manifold drive sprocket to rotate pulse arms for bag and cage removal.

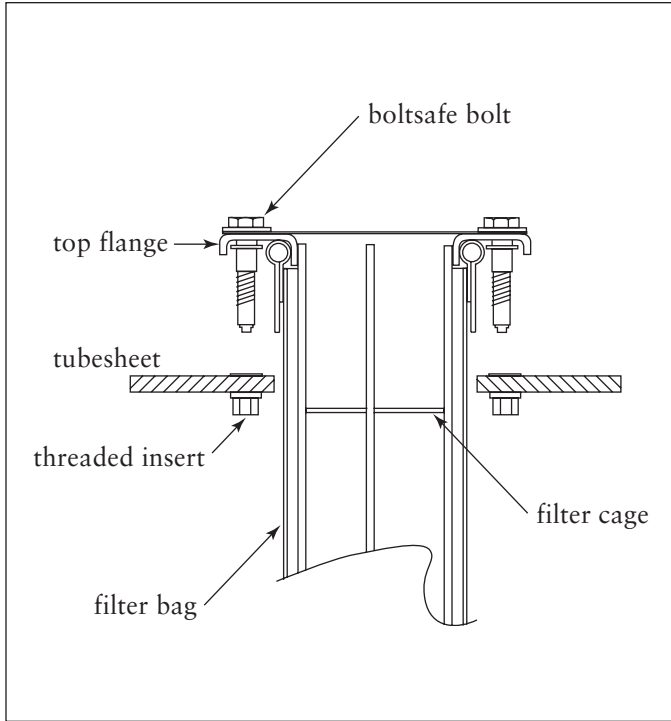

Filter Cage and Bag Installation, Boltsafe

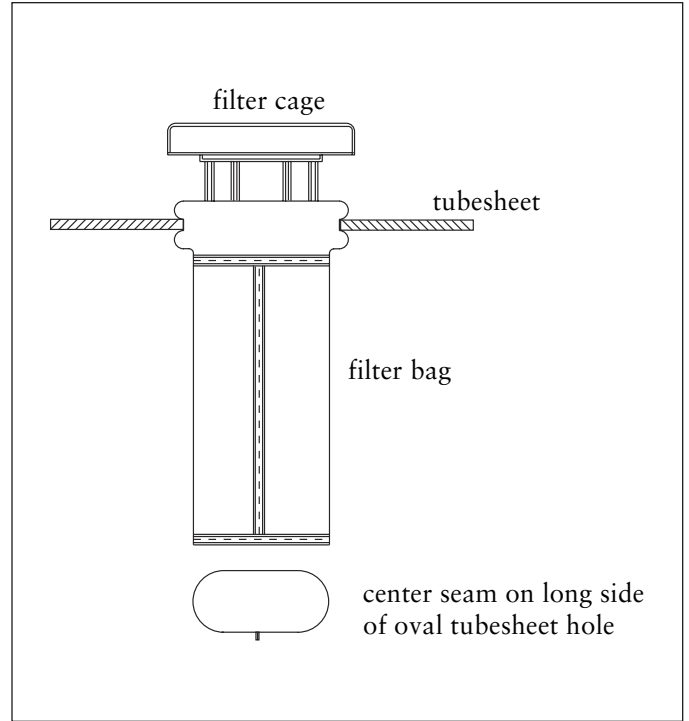

Filter Cage and Bag Installation, Snap-In

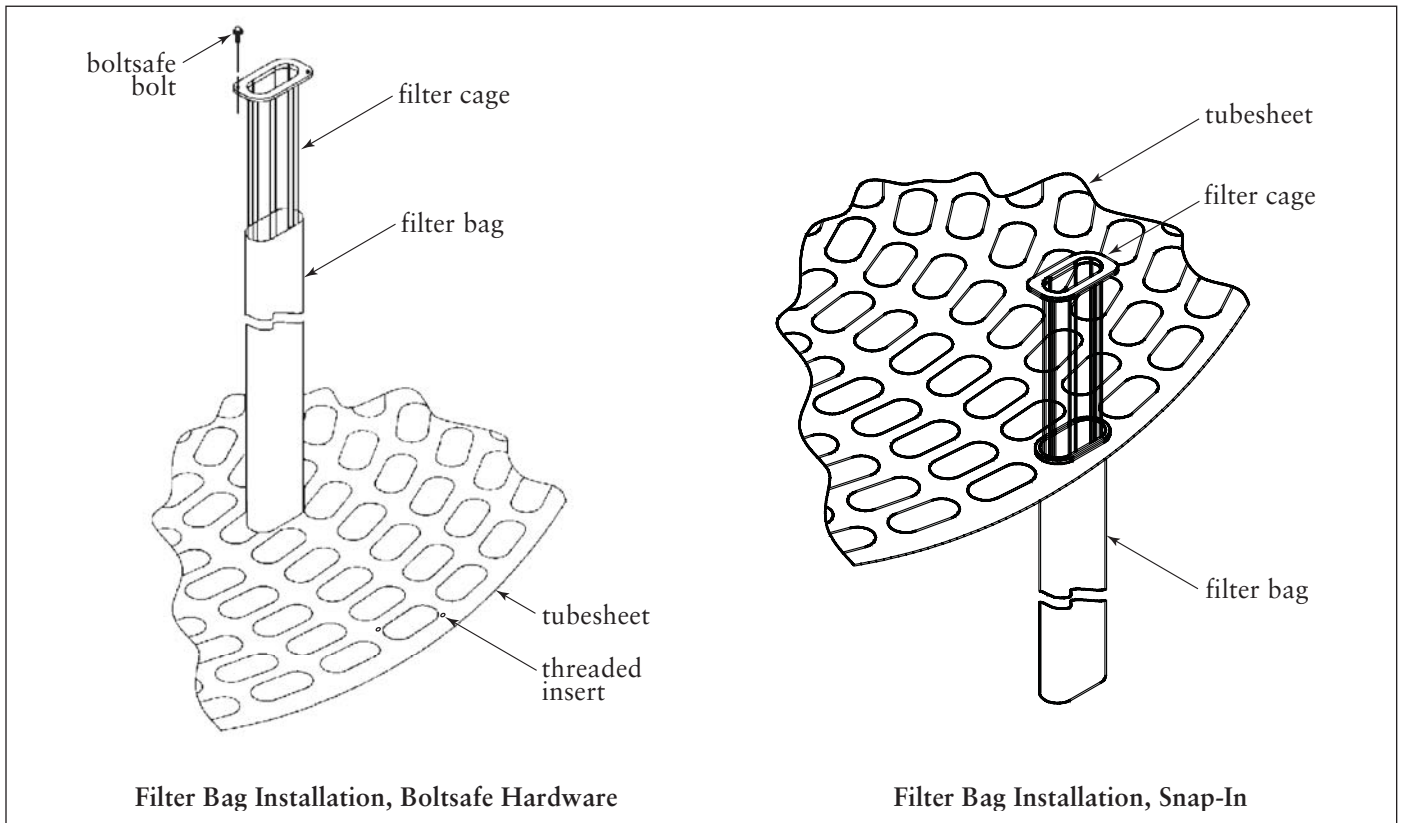

Filter Bag Installation, Boltsafe Hardware

Filter Bag Installation, Snap-In

Filter Bag Installation

Preliminary Start-Up Check

1. Check all electrical connections for tightness and contact.
2. Check for and remove all loose items in or near the inlet and outlet of the unit.
3. Check that all remote controls are wired into the control system, and all service switches are in the OFF position.
4. Check that all optional accessories are installed properly and secured.
5. Check that hopper discharge is open and the storage container is sealed, if equipped.
6. Turn power ON at source.
7. Turn the cleaning air blower ON then OFF to check for proper rotation. Confirm actual rotation by referencing the rotation arrow located on the belt guard. Proper rotation is generally counterclockwise.

To reverse cleaning air blower rotation, three-phase power supply:

Turn electrical power OFF at source and switch any two leads on the output-side of the fan-motor starter.

8. Turn the system blower ON then OFF to check for proper rotation. Confirm actual rotation by referencing the manufacturer's rotation arrow.

To reverse system blower rotation, three-phase power supply:

Turn electrical power OFF at source and switch any two leads on the output-side of the fan-motor starter.

9. Adjust the system blower for proper airflow by adjusting the volume control damper on the blower discharge, if equipped.
10. Check arm rotation by observing from outside the collector with main fan and PD pump locked out.



CAUTION!

- Do not look into blower outlet to determine rotation.
- Check that the exhaust plenum is free of tools or debris before checking blower/fan rotation.
- Stand clear of exhaust to avoid personal injury.

Start-Up

1. Start the positive-displacement cleaning blower and check for proper rotation.
2. Turn power to timer and solenoid ON.
3. Check solenoid and diaphragm valve operation.
4. Adjust the cleaning control timer to allow the cleaning system air reservoir tank pressure to rise to 9 psi between pulses. Too short of an OFF time will result in inadequate cleaning pressure and will adversely impact filter performance; too long of an OFF will result in the pressure relief valve discharging cleaning air.
5. Close the isolation petcock between the positive-displacement blower and the gauge.
6. Check the cleaning drive for proper rotation (clockwise).
7. Start the system as shown in Start-Up Sequence.
8. Adjust the system blower for proper airflow with the volume control damper, if equipped.
9. Measure initial pressure drop across the tube sheet and filter bags and start dust-creating process. Pressure drop will gradually rise until an equilibrium pressure drop is achieved, generally 3 to 4 "wg for seasoned filters, although anything between 1 to 6 "wg is considered normal.

Start-Up/Shut-Down Sequences

The recommended sequences for motor start-up and shut-down are outlined below. These sequences assure minimal material build-up in the hopper of the collector. Not following these sequences can adversely impact the life of the filters and may result in equipment damage.

Start-Up Sequence

1. Pneumatic conveyor or transfer blower, if equipped.
2. Rotary airlock and screw conveyor **with separate drives**: Start simultaneously; **with common drive**: Start.
3. Manifold drive.
4. Pulse timer.
5. Positive-displacement cleaning blower.
6. Main blower.

Shut-Down Sequence

1. Main blower.
2. Positive-displacement cleaning blower.
3. Pulse timer.
4. Manifold drive.
5. Rotary airlock and screw conveyor **with separate drives**: Shut-down simultaneously; **with common drive**: Shut-down.
6. Pneumatic conveyor or transfer blower, if equipped.

Service Information



CAUTION!

- Turn power off and lock out electrical power sources before performing service or maintenance work.
- Turn air supply to collector OFF and depressurize the air tank before service or maintenance work is performed.

Operational Checklist

1. Monitor overall performance of the collector.
2. Monitor exhaust.
3. Monitor pressure drop across filters.
4. Monitor dust disposal.

Maintenance

Weekly

1. Check that pressure drop is within normal operational range (from 1 to 6 "wg).
2. Check for proper air pressure at reservoir (8 PSI for 570-608 collectors and 9PSI for all larger units).
3. Check for proper lubricant level in positive-displacement blower.

Quarterly

1. Check condition of the clean-air plenum. If dust accumulation is present, check filter bags for wear, tears or loose seals. Replace as necessary.
2. Check solenoid and diaphragm valve operation.
3. Check door seals and replace as necessary.
4. Check cleaning arm drive chain and positive-displacement blower belt tension.
5. Check positive-displacement blower and gear reducer oil levels. Add oil through breather mounting holes or other oil fill locations. Reference the blower owner's manual for proper lubricant.
 - 0°F-32°F - use ISO 68 lubricant
 - 32°F-90°F - use ISO 100 lubricant
 - 90°F-120°F - use ISO 150 lubricant
6. Inspect explosion vents, if applicable, for signs of wear or cracks.
7. Inspect inlet area including air straightener section.

Troubleshooting

Problem	Probable Cause	Remedy
Blower fan and motor do not start	Improper motor wire size	Rewire using the correct wire gauge as specified by national and local codes.
	Not wired correctly	Check and correct motor wiring for supply voltage. See motor manufacturer's wiring diagram. Follow wiring diagram and the National Electric Code.
	Unit not wired for available voltage	Correct wiring for proper supply voltage.
	Input circuit down	Check power supply to motor circuit on all leads.
	Electrical supply circuit down	Check power supply circuit for proper voltage. Check for fuse or circuit breaker fault. Replace as necessary.
Blower fan and motor start, but do not stay running	Incorrect motor starter heater elements installed	Check for proper heater elements and replace if necessary.
	Electrical circuit overload	Check that the power supply circuit has sufficient power to run all equipment.
Clean-air outlet discharging dust	Filter bags not installed correctly	See Filter Bag Installation.
	Torn or damaged filter bags	Inspect filter bags using a flashlight. Replace as necessary. Use only genuine Donaldson replacement parts. See Filter Bag Installation.

Troubleshooting

Problem	Probable Cause	Remedy
Insufficient airflow	Blower rotation backwards	Compare rotation to blower manufacturer's rotation arrow.
	Access doors open or not closed tight	Check that all access doors are in place and secured.
	Fan exhaust area restricted	Check fan exhaust area for obstructions. Remove material or debris.
	Filter bags need replacement	Remove and replace using genuine Donaldson replacement filters. See Filter Bag Installation.
	Pulse cleaning not energized	Use a voltmeter to check supply voltage to the timer. Check and replace timer fuse if necessary. See Solid-State Timer Installation.
	Solenoid valve failure; constant air leakage	Replace solenoid valve. Lock out all electrical power to the unit and bleed the compressed air system before removing the valve.
	Solenoid valve failure; failure to open	Check voltage output from Solid-State Timer. If output voltage is present, replace the solenoid valve. Lock out all electrical power to the unit and bleed the compressed air system before removing the valve.
	Diaphragm valve failure	Replace the primary and secondary diaphragms and springs. Note: To reassemble the smaller secondary diaphragm, remove the solenoid valve and pipe fittings and push down on the top of the diaphragm to hold it in the closed position while tightening the retaining bolts. Lock out all electrical power to the unit and bleed the compressed air system before any component repair work is completed.
	Solid-State Timer failure	Using a voltmeter, check supply voltage to the timer board. Check and replace the fuse on the timer if necessary. If the fuse is good and input power is present, but output voltage to the solenoid valve is not, replace the timer. See Solid-State Timer Installation.
	Solid-State Timer out of adjustment	See Solid-State Timer and Timer Wiring Diagram.

The Donaldson Torit Warranty

Donaldson warrants to the original purchaser that the major structural components of the goods will be free from defects in materials and workmanship for ten (10) years from the date of shipment, if properly installed, maintained and operated under normal conditions. Donaldson warrants all other Donaldson built components and accessories including Donaldson Airlocks, TBI Fans, TRB Fans, Fume Collector products, Donaldson built electrical control components and Donaldson built Afterfilter housings for twelve (12) months from date of shipment. Donaldson warrants Donaldson built filter elements to be free from defects in materials and workmanship for eighteen (18) months from date of shipment. Donaldson does not warrant against damages due to corrosion, abrasion, normal wear and tear, product modification, or product misapplication. Donaldson also makes no warranty whatsoever as to any goods manufactured or supplied by others including electric motors, fans and control components. After Donaldson has been given adequate opportunity to remedy any defects in material or workmanship, Donaldson retains the sole option to accept return of the goods, with freight paid by the purchaser, and to refund the purchase price for the goods after confirming the goods are returned undamaged and in usable condition. Such a refund will be in the full extent of Donaldson's liability. Donaldson shall not be liable for any other costs, expenses or damages whether direct, indirect, special, incidental, consequential or otherwise. The terms of this warranty may be modified only by a special warranty document signed by a Director, General Manager or Vice President of Donaldson. Failure to use genuine Donaldson replacement parts may void this warranty. **THERE EXIST NO OTHER REPRESENTATIONS, WARRANTIES OR GUARANTEES EXCEPT AS STATED IN THIS PARAGRAPH AND ALL OTHER WARRANTIES INCLUDING MERCHANTABILITY AND FITNESS FOR A PARTICULAR PURPOSE, WHETHER EXPRESS OR IMPLIED ARE HEREBY EXPRESSLY EXCLUDED AND DISCLAIMED.**

Parts and Service

For genuine Donaldson Torit replacement filters
and parts, call the Parts Express Line

800-365-1331 USA
800-343-3639 within Mexico

www.donaldsontorit.com

For faster service, have unit's model and serial number,
part number, description, and quantity available.



Donaldson[®]
Filtration Solutions

Donaldson Company, Inc.
Industrial Air Filtration
P.O. Box 1299
Minneapolis, MN 55440-1299
donaldsontorit@donaldson.com

Donaldson Company, Inc. is the leading designer and manufacturer of dust, mist, and fume collection equipment used to control industrial-air pollutants. Our equipment is designed to help reduce occupational hazards, lengthen machine life, reduce in-plant maintenance requirements, and improve product quality.