

Field Assembly
Instructions

Field Assembly Manual

Bolted LP Reverse Air Filter



Throughout this manual statements indicating precautions necessary to avoid equipment failure are referenced in a **Note**. Statements indicating potential hazards that could result in *personal injury* or *property damage* are referenced in a **CAUTION!** box.

Illustrations are for reference only, as actual product may vary.

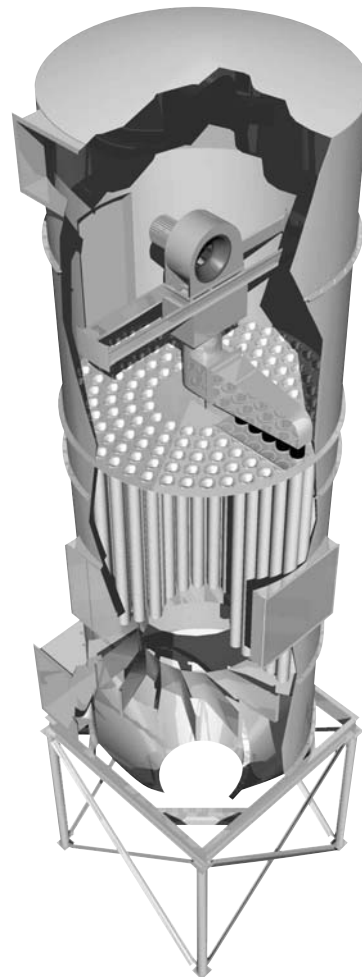

This manual is property of the owner. Leave with the unit when set-up and start-up are complete. Donaldson Company reserves the right to change design and specifications without prior notice.



CAUTION!

Application of Dust Control Equipment

- Combustible materials such as buffing lint, paper, wood, aluminum or steel dust, weld fume, or flammable solvents represent fire or explosion hazards. Use special care when selecting and operating all dust or fume collection equipment when combustible materials are present to protect workers and property from damage due to fire and/or explosion. Consult and comply with National and Local Codes relating to fire or explosion and all other appropriate codes when determining the location and operation of dust or fume collection equipment.
- When combustible materials are present, consult with an installer of fire extinguishing systems familiar with these types of fire hazards and local fire codes for recommendations and installation of fire extinguishing and explosion protection systems. Donaldson Torit dust collection equipment is not equipped with fire extinguishing or explosion protection systems.
- DO NOT allow sparks, cigarettes or other burning objects to enter the hood or duct of any dust or fume control equipment as these may initiate a fire or explosion.
- For optimum collector performance, use only Donaldson Torit replacement parts.



This manual contains specific precautionary statements relative to worker safety. Read thoroughly and comply as directed. Discuss the use and application of this equipment with a Donaldson Torit representative. Instruct all personnel on safe use and maintenance procedures.

IMPORTANT

Thank you for purchasing a Donaldson Torit reverse air filter. Your new Donaldson Torit filter is built to the highest industry standards. Great care has been taken to design and manufacture a high quality, low maintenance product that is economical to use and maintain.

This manual is intended to assist in the assembly of your filter and should be used in conjunction with the “Installation, Operation and Maintenance Manual” provided. The instructions in this manual are general in nature and apply to a variety of models. Each situation dictates the need for any special precautions and it is the user’s responsibility to ensure that adequate safety measures are employed in installation, operation and maintenance. As always, follow good safety practices around all equipment.

Preliminary Inspection

Donaldson Torit filters are shipped as completely assembled as transportation allows. Due to the nature of the shipping requirements and the filter size, the LP is fabricated as a bolt together unit to enable quick and easy assembly and installation. Upon arrival inspect all components for damage that may have occurred during shipping. Check the bill of lading or packing list to verify the proper equipment and quantities. Should any discrepancies arise contact the carrier immediately.

All filters are equipped with lifting ears on the plenum (top) section. Nylon straps with clevises should be attached to all lift ears and lifted using appropriate lifting equipment (i.e. crane). Units that are partially assembled should be off loaded using appropriate lifting equipment (i.e. crane , forklift) using nylon strapping and or wooden blocks to prevent damage to the filter.

Off-loading and Staging

The components for your filter are grouped together by section (i.e. bag section panels, inlet section panel, hopper panels, etc.) to assist in organizing the staging and assembly. It is advised that before unloading the filter that a large flat staging area be provided near the actual filter installation site so that components may be separated and staged in order of use. Components should be layed out so that equipment used to move them can access the individual parts easily.

Assembly Requirements

The Donaldson Torit filter is designed to bolt together without the need of field modifications or fabrication. It is assumed that the installers are experienced and competent in the erection of similar structures. This filter is not a do-it-yourself kit. It is however designed and manufactured so that assembly time is minimized.



CAUTION!

- Misuse or modification of this equipment may result in personal injury.
- Do not misuse or modify.

Order of Assembly

The following list summarizes the order in which to assemble the filter. This is a suggested sequence that years of experience have proven to be effective. Depending on your situation a different sequence may be more appropriate. Each of the following steps is explained in detail on the following pages. Please refer to them for clarification and further important details. This list is intended as a summary only.

- 1) Assemble the channel frames.
- 2) Erect legs and cross bracing and place channel frame onto legs.
- 3) Assemble tubesheet. This step is critical because all other sections will be assembled on the tubesheet.
- 4) Assemble hopper and lift into place.
- 5) Assemble inlet section and lift into place.
- 6) Assemble bag sections and lift one onto the other, bolt together and set aside.
- 7) Assemble plenum top and set aside.
- 8) Assemble plenum access section and set aside.
- 9) Lift tubesheet and attach upper support column if provided. Lift tubesheet onto bag sections.
- 10) Lift access section onto tubesheet and secure. Install internal cleaning mechanism.
- 11) Install bags and cages in filter.
- 12) Lift plenum top onto access section. Secure in place.
- 13) Attach exhaust ducting to plenum
- 14) Attach access platforms and ladders.
- 15) Lift filter assembly onto inlet section and bolt together.
- 16) Install additional ducting and supports as necessary.
- 17) Install rotary airlock onto filter hopper.
- 18) Install magnehelic gauge.
- 19) Install all electrical connections.
- 20) Inspect all structural connections for proper torque.
- 21) Inspect all electrical, and mechanical connections.
- 22) Place filter into service.

1) Channel Frame Assembly

The channel frame consists of three different pieces in the following quantities:

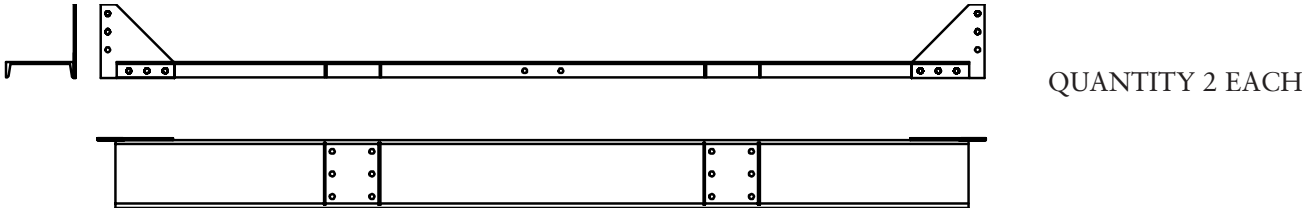

QUANTITY 2 EACH

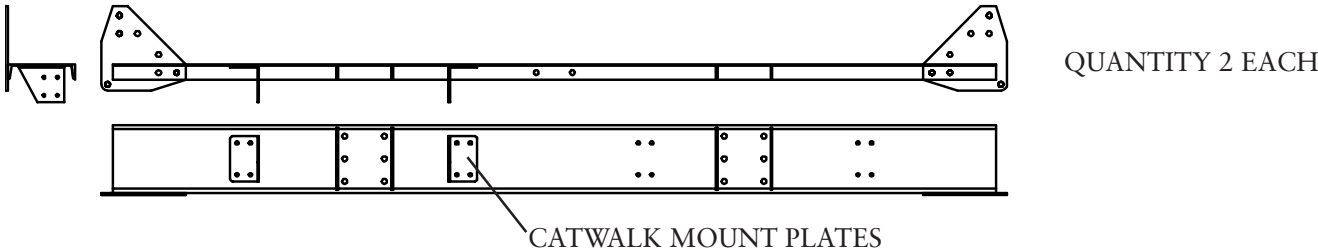

QUANTITY 2 EACH



QUANTITY 4 EACH

Place the channel pieces on a flat level surface for assembly. Use the 1" unc A325 bolts provided for all connections. Locations where bolts pass through channel legs must have a wedge washer placed on the bolt for proper connection. Note catwalk mounts can be bolted onto any side, however attention must be paid to the orientation of the catwalk entry.

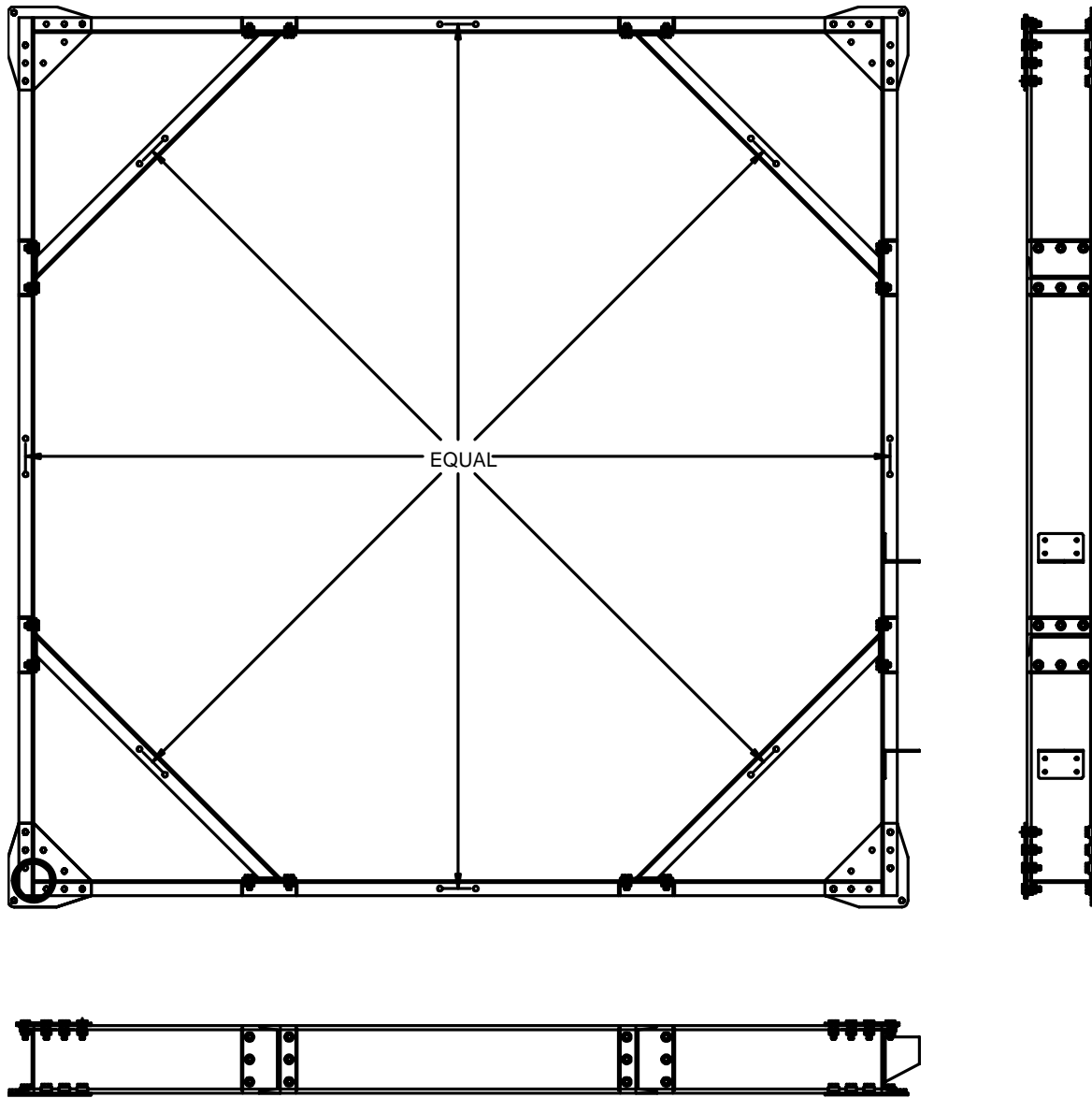

The channel frame as viewed from the top and sides.

Level and square all members of the frame. Tighten all bolts. Note the channel member with the two protruding plates. These plates are mounts for the lower catwalk and it is important that the frame is placed in the correct orientation so that the access ladders will line up.

2) Leg and Cross Brace Assembly

The legs and cross braces will vary in size and qty per job. The following example covers typical erection protocol.

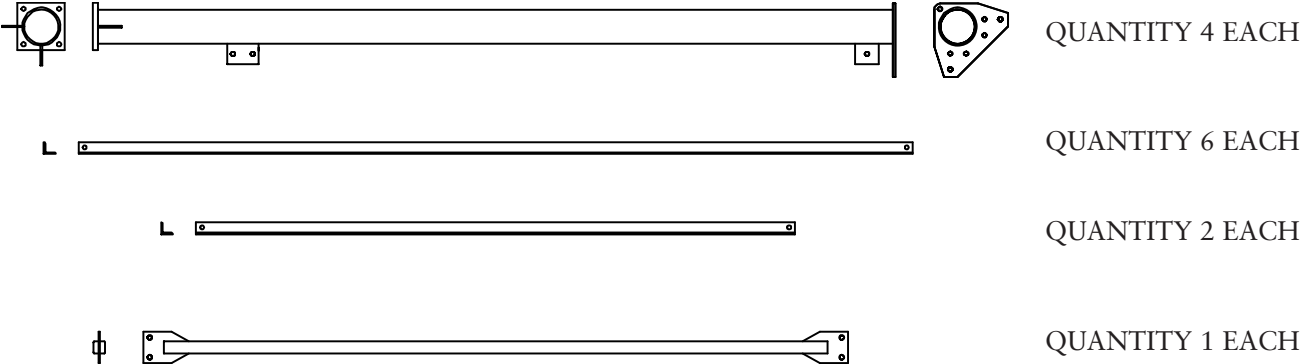

Lift each leg onto the foundation. Temporary supports must be used to stabilize the leg columns. Bolt the cross braces on the legs. Bolt the horizontal brace if provided. Bolts should be hand tight at this point to allow for alignment of the legs to the channel frame. Lift channel frame into place and bolt to legs. Level the top of the frame so that the filter will not lean to any one direction. Tighten all bolts. Some area's building codes require that bolt torque be checked by an approved testing service. Please check your local building codes.

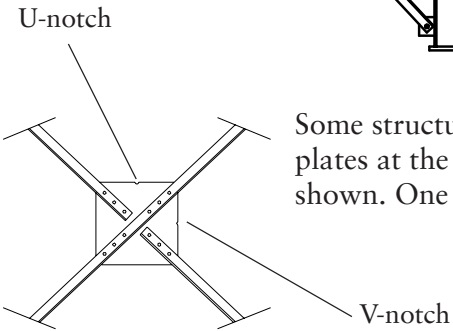
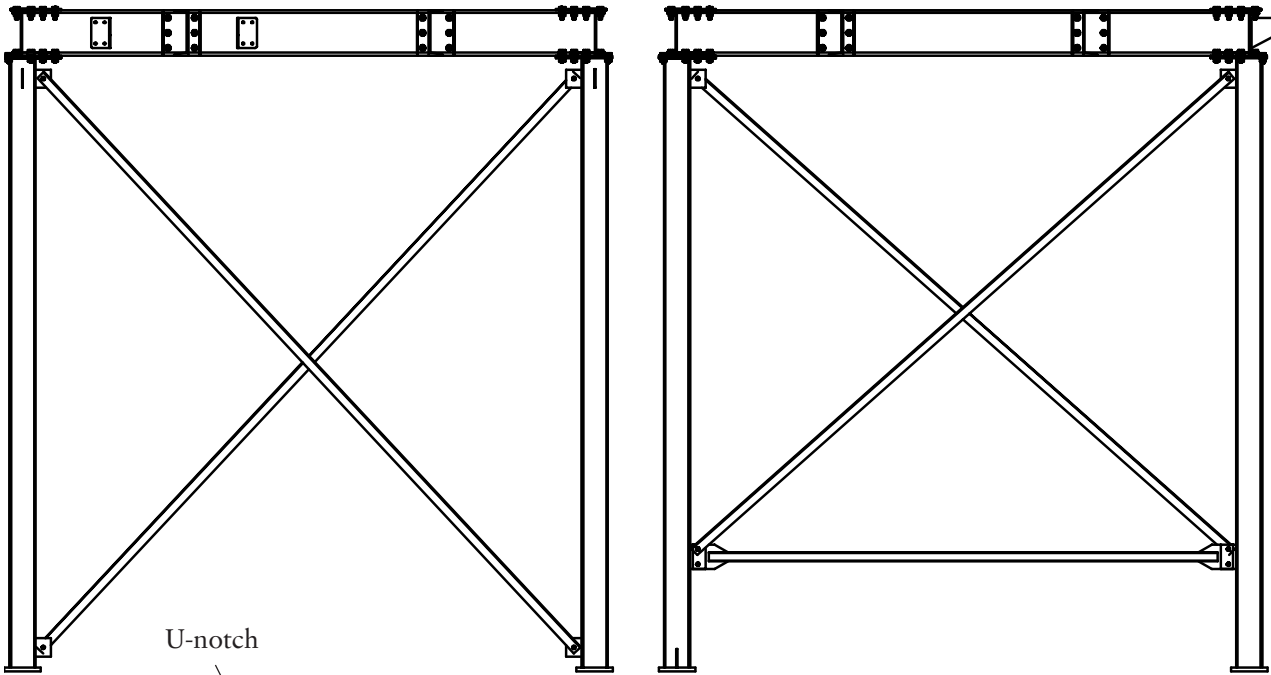

Some structures require double x-braces. These will have splice plates at the point of intersection. The plates are oriented as shown. One long brace should be placed in each direction.

3) Tubesheet Assembly

The tubesheet consists of the following items:

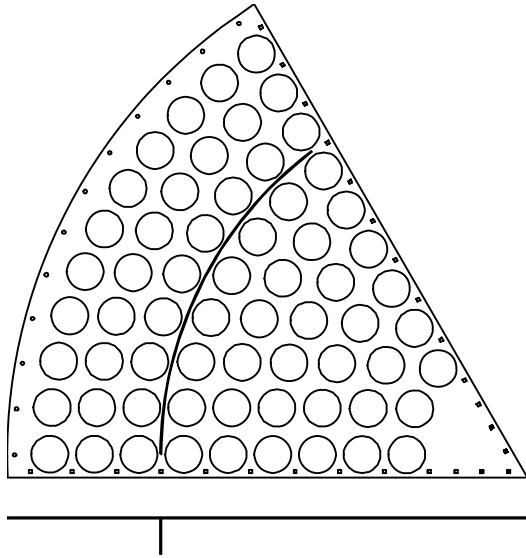

QUANTITY 6 EACH

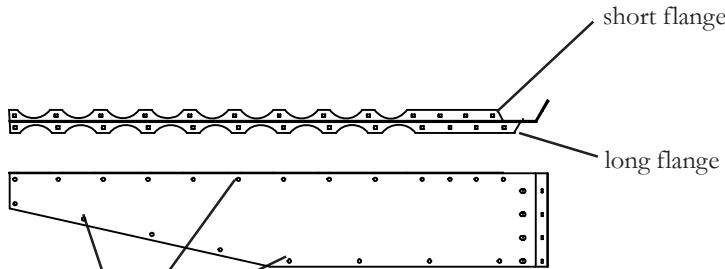

QUANTITY 6 EACH

Use 1/2 unc x 3/4 bolts in these holes

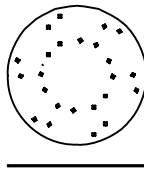

QUANTITY 1 EACH

The assembly of the tubesheet is critical because it is used as a template for the assembly of all the other sections. The tubesheet radial stiffeners consist of two similar pieces bolted together. It is important that the correct pieces are placed together. The pieces are distinguished by the length of the flange (see figure above). The stiffeners must be bolted together forming a central hexagonal tube (see diagram next page). The bolts should be hand tightened at first so that all the pieces can be aligned before tightening. After the stiffeners are together place a bead of silicone on each side of the stiffener flange so that an air tight seal is developed when the tubesheet pie section is bolted in place. After all the pie sections are in place bolt the center plate with bearing in place. Align and tighten all bolts. Note: on some models the pie sections are in multiple pieces and require splice plates.

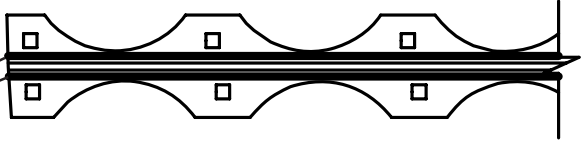
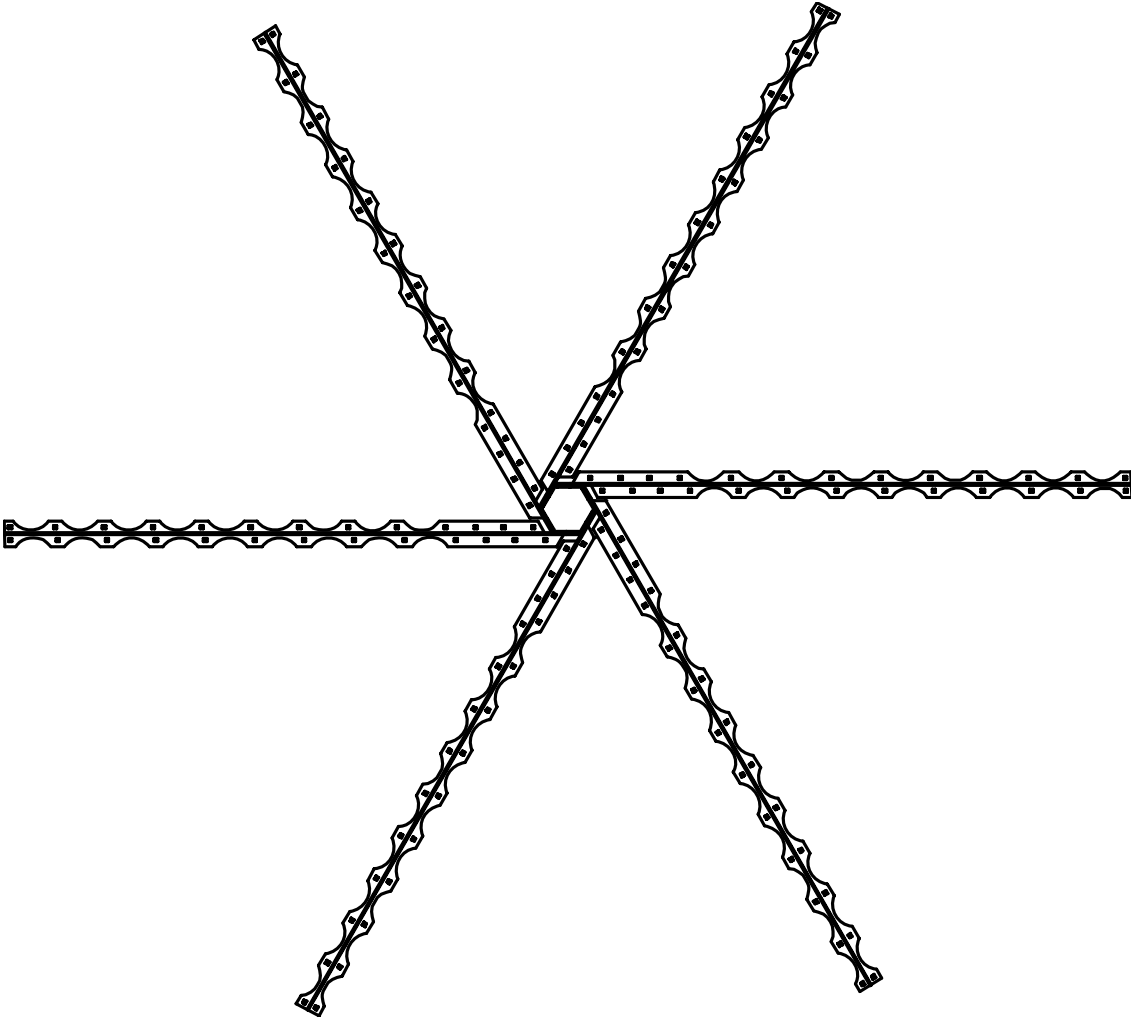

1/4" bead of silicone

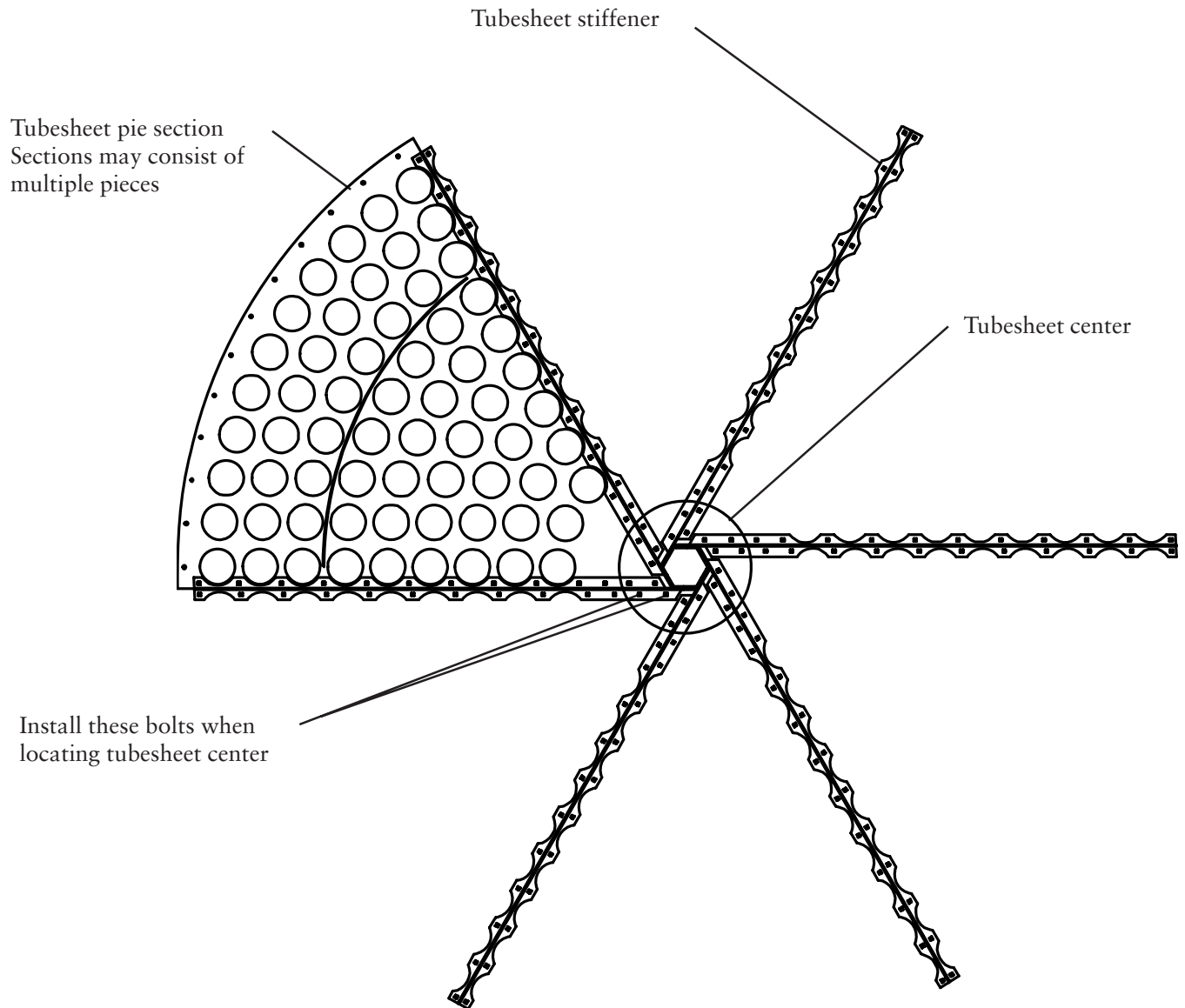

4) Hopper Assembly

The hopper consists of the following items:

The hopper is assembled upside down on top of the tubesheet to insure proper fit as the filter is erected.

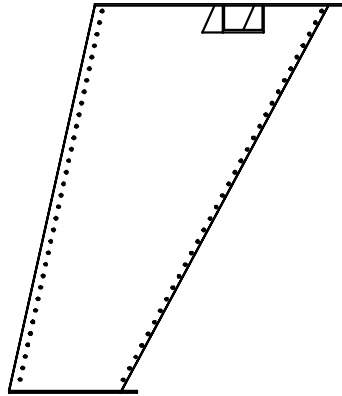

QUANTITY 8 EACH
On 528 and up there
are also 6 mid hopper
panels



QUANTITY 8 EACH
On 528 and up there
are also 6 mid hopper
splice plates

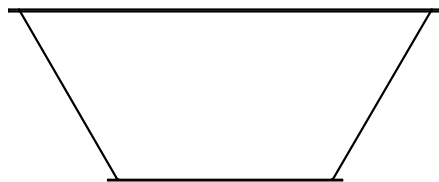

QUANTITY 1 EACH

Place the first panel with large flange onto the tubesheet and align flange holes with outer tubesheet bolt holes. Temporarily support the other end of the panel. Place a bead of silicone on one splice plate as shown (see next page). Bolt splice plate to the inner side of the panel. All carriage bolts are placed with heads on the inner surfaces of the filter. A neoprene bonded washer should be placed on the bolt on the outside of the filter followed by a hex nut. Position next panel in place and repeat (see page 12). After all panels are in place apply a bead of silicone to the smaller flange and place the lower cone onto the hopper. On larger models there is a middle hopper section consisting of 6 panels. Assemble this section and lift onto previously assembled section. Care must be taken to properly orient the lower cone so that the discharge flange on the airlock transition is correctly positioned for your particular installation. Tighten all bolts and remove hopper from tubesheet. Right the hopper and lift it into place on the frame. Attach the hopper using the provided 1" unc bolts.

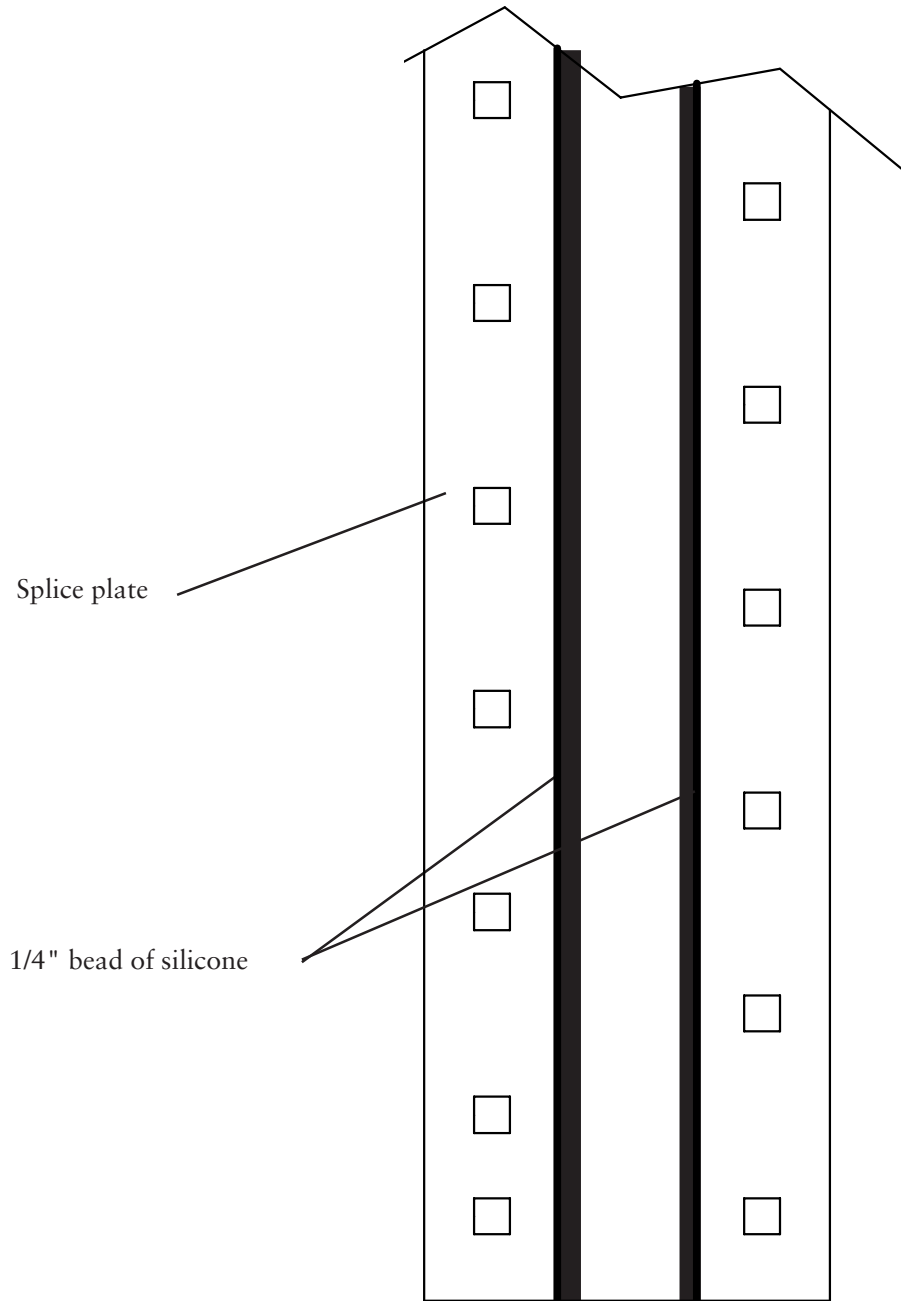

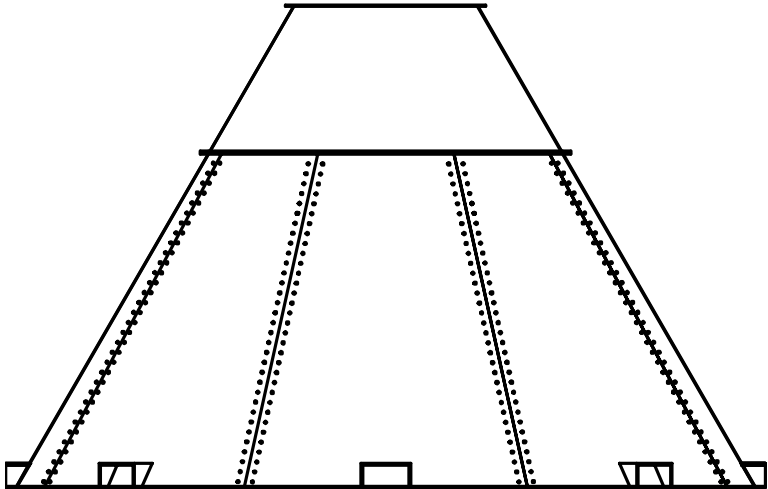
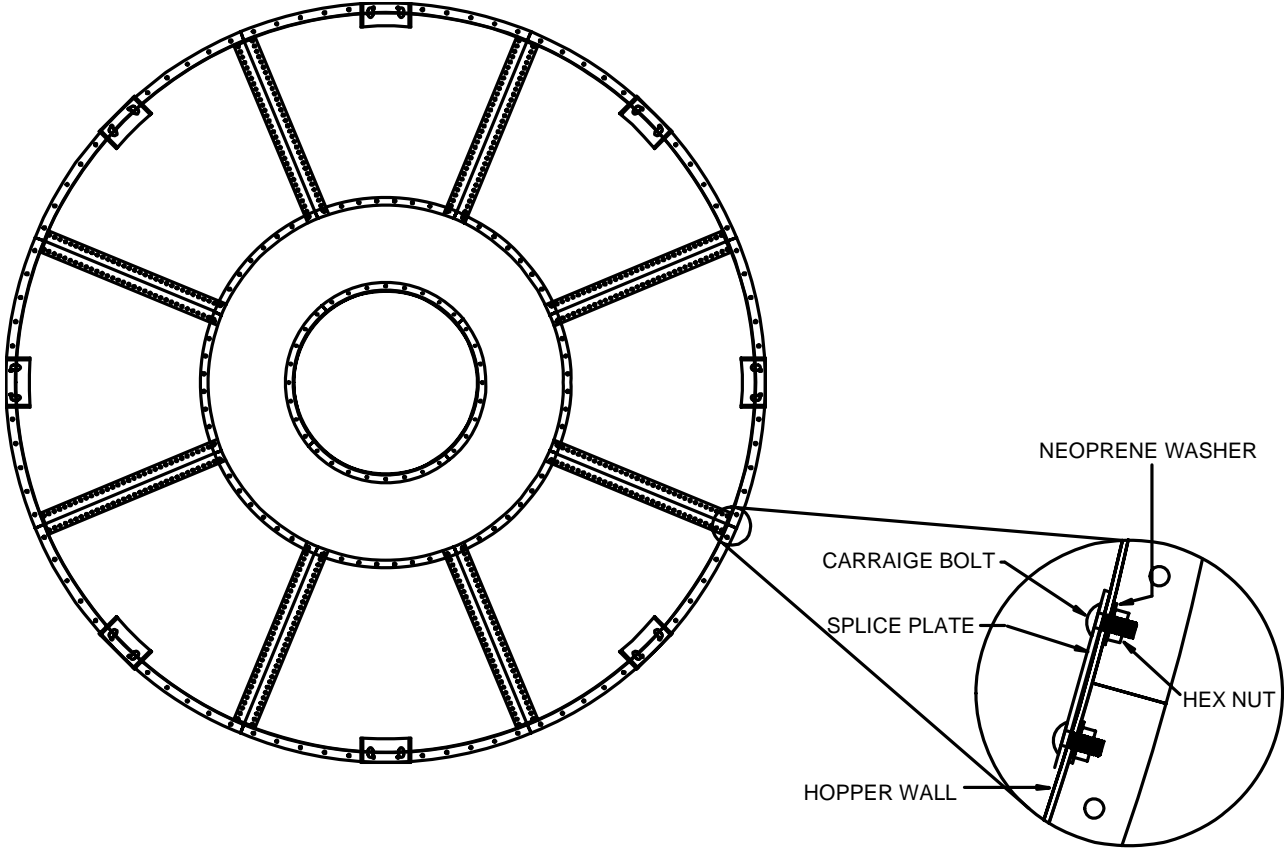

5) Inlet Assembly - S.E.A.L.

The S.E.A.L. inlet consists of the following items:

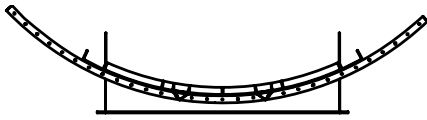

QUANTITY 1 EACH

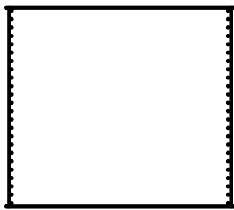
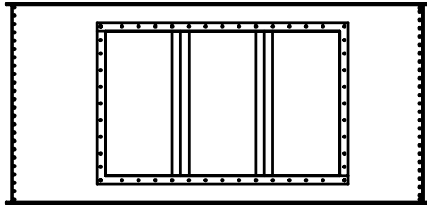

This panel has one or two deflector mounts.

QUANTITY 1 or 2 EACH

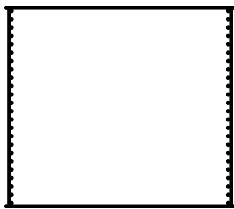

This panel is plain

QUANTITY 2 or 4 EACH

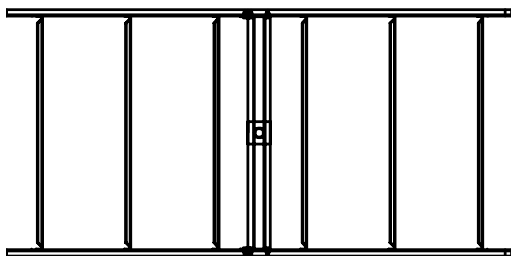

Deflector is usually shipped assembled.

QUANTITY 1 EACH

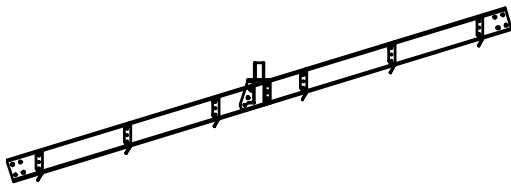

QUANTITY 4 or 6 EACH

Place the panels onto the tubesheet and align flange holes. Place silicone on splice plates and position into place. Install all splice plate bolts as shown in section 3 and tighten. Install deflector plates between deflector rails. Align rails and tighten deflector plate bolts. Lift deflector assembly into place and install mount bolts.

Prepare the top hopper flange with a bead of silicone placed between the flange holes and the interior of the hopper. Remove inlet section from tubesheet and lift onto hopper using the bolt-on assembly lift ears provided. It is helpful to stagger flange seams as the filter is stacked up if orientation allows. Therefore it is recommended that each succeeding section be rotated so that maximum overlap is achieved.

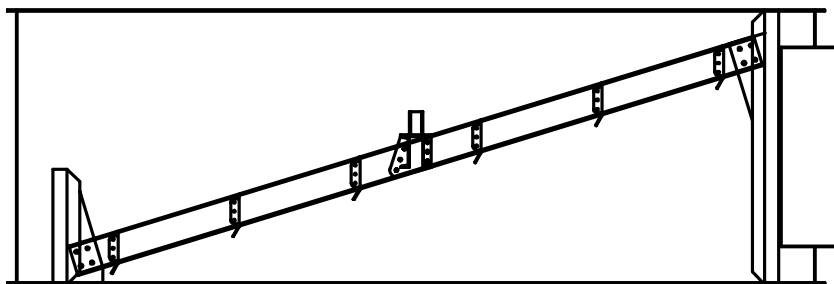
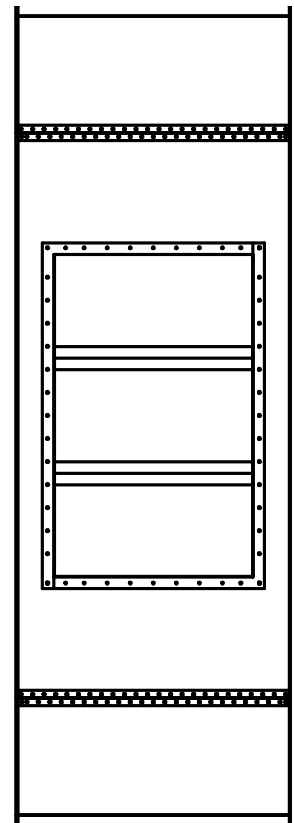
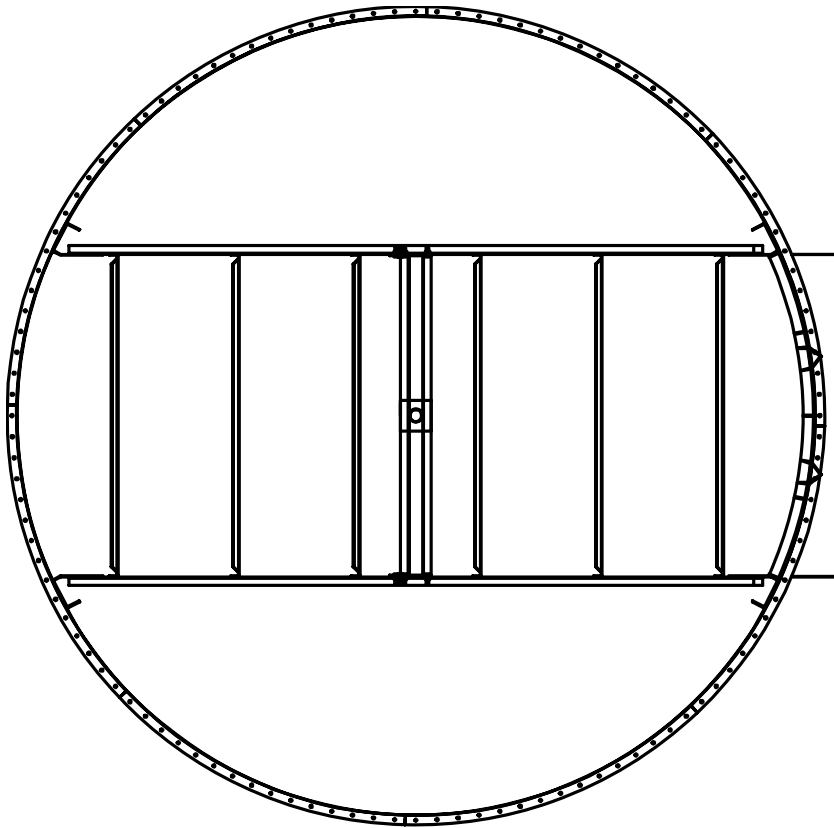

6) Inlet Assembly -Tangential

The tangential inlet consists of the following items:

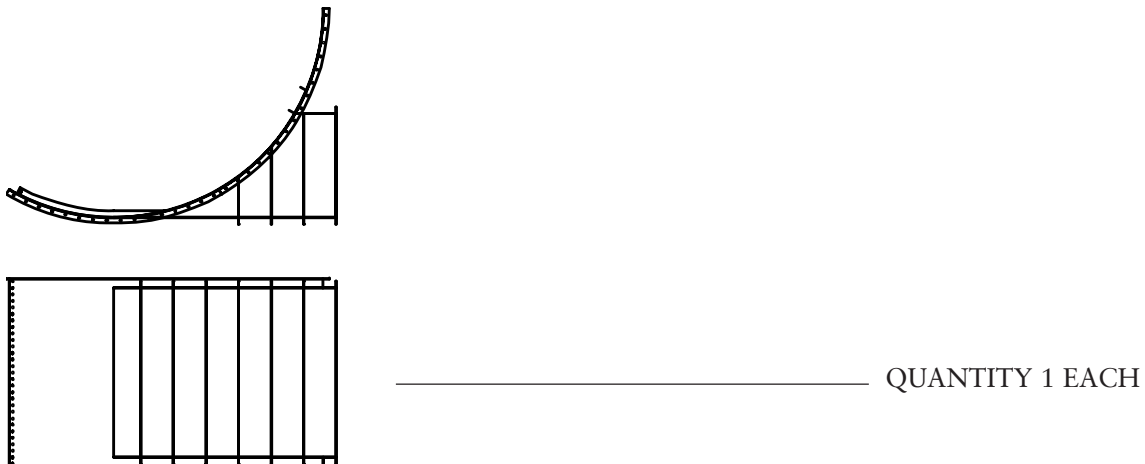
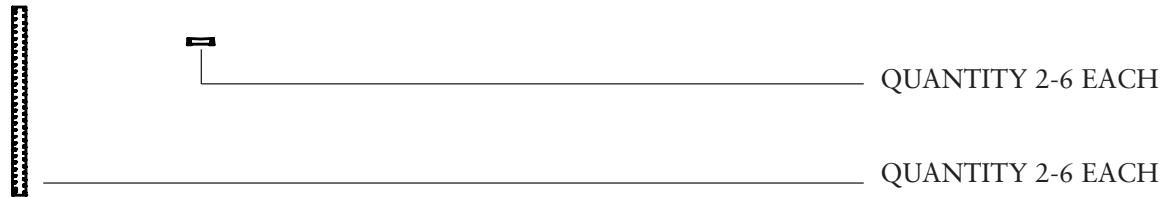

Place the short panels onto the tubesheet and align flange holes. Place silicone on splice plates and position into place. Install all splice plate bolts as shown in section 3 and tighten. Bolt deflector plates to wall and each other. Deflectors can be installed for clockwise rotation (shown) or counter clockwise (opposite shown). Tighten deflector plate bolts. Lift deflector assembly off of tubesheet and set aside.

Place the inlet walls onto tubesheet and align flange holes. Place silicone on splice plates and position into place. Install all splice plate bolts as shown in section 3 and tighten. Install spiral deflector splices on top of spiral deflectors with bolt heads down.

Prepare the top inlet section flange with a bead of silicone placed between the flange holes and the interior of the inlet section. Lift the deflector section on to the inlet section and secure with bolts.

Prepare the top hopper flange with a bead of silicone placed between the flange holes and the interior of the hopper. Remove inlet section from tubesheet and lift onto hopper using the bolt-on assembly lift ears provided. It is helpful to stagger flange seams as the filter is stacked up if orientation allows. Therefore it is recommended that each succeeding section be rotated so that maximum overlap is achieved.

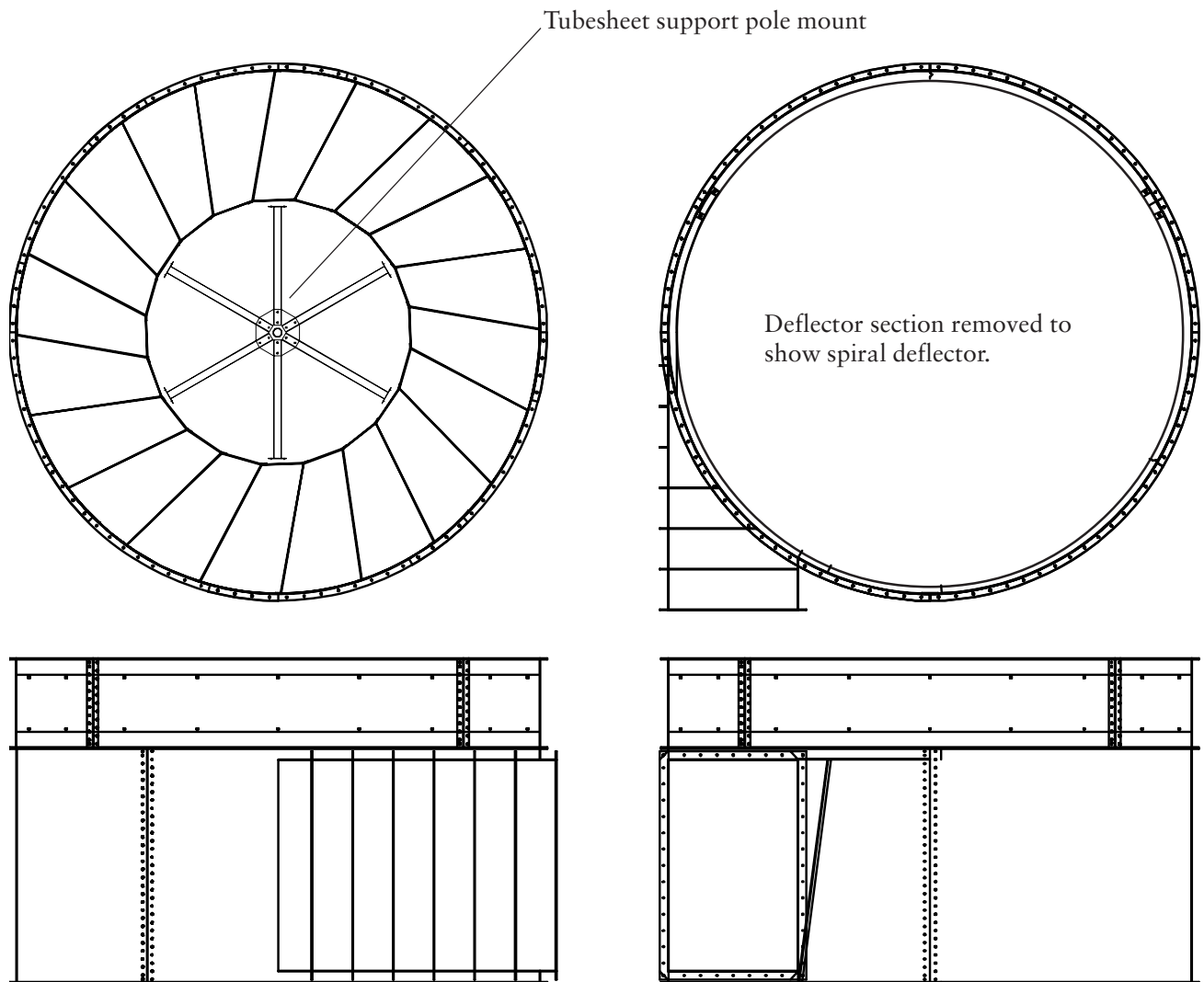

7) Bag Section Assembly

The bag section consists of the following items:

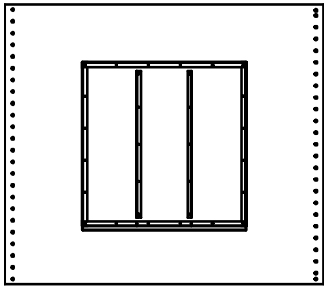

QUANTITY 8 EACH

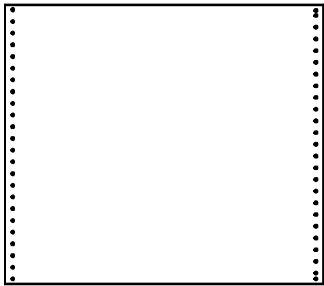

QUANTITY 0 or 8 EACH



QUANTITY 8 or 16 EACH

The bag section consists of two barrel sections each of which has four explosion relief panels. One panel may have a magnetic gauge filter installed near the top corner. If so this panel must be used on the upper bag section and located near the door panel of the access section. If no filter is present then see page 24. Place the panels onto the tubesheet and assemble with splice plates as explained in previous sections. Support the first bag section on 4" x 4" blocks under the lower flange in 8 evenly spaced places. The bag section is blocked for easier bag installation in step 11. Lift the second bag section onto the other prepared bag section. Align and bolt in place. It is recommended that the barrel sections be rotated with respect to each other so that maximum flange overlap is achieved (see next page).

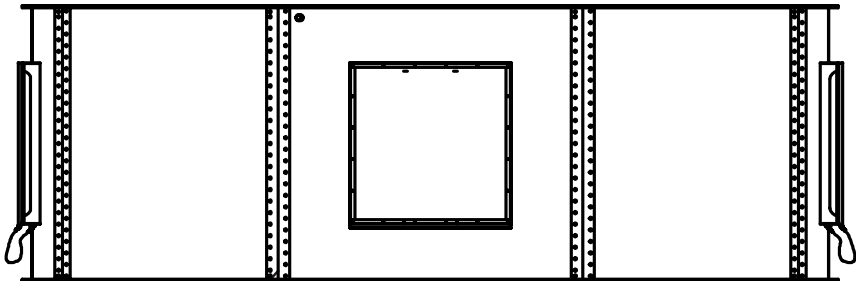
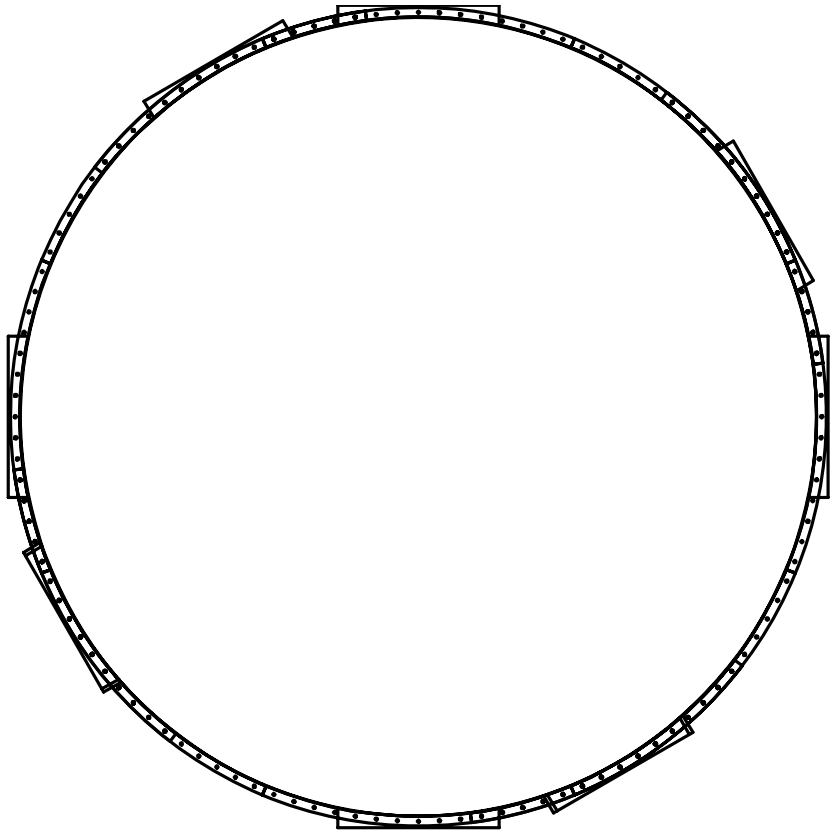

Overlap flange seams

Rotate with respect
each other

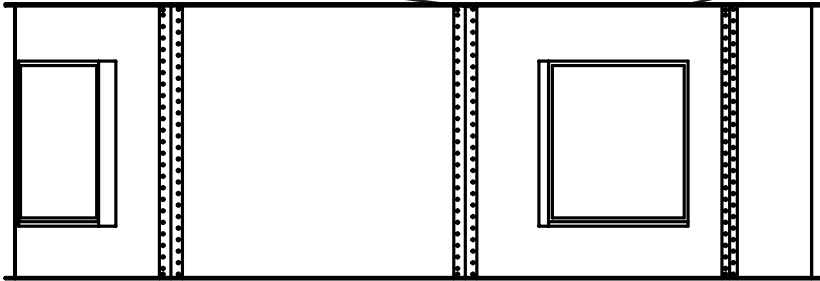

8) Plenum Top Assembly

The plenum top consists of the following items:



QUANTITY 1 EACH

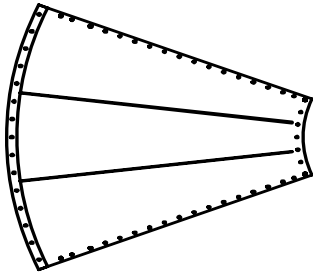

QUANTITY 8 EACH



QUANTITY 3 or 6 EACH

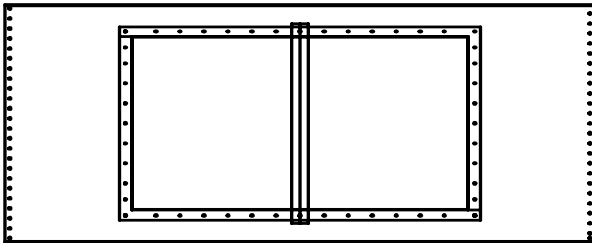
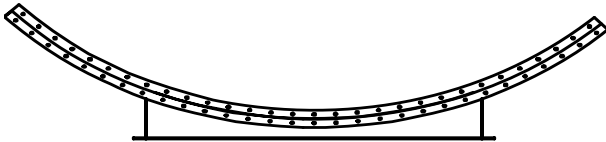

QUANTITY 1 EACH



lift ear

QUANTITY 4 or 7 EACH



sealing plate

QUANTITY 8 EACH

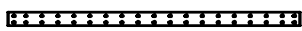

top splice plate

QUANTITY 8 EACH



wall splice plate

QUANTITY 4 or 7 EACH

Place the wall panels onto the tubesheet and assemble with splice plates as discussed in previous sections leaving attaching the lift ears at the same time. Align and tighten all the wall splice bolts. Place one of the eight top panels onto the top wall flange and bolt in place. Temporarily support the other end of the panel. Install the remaining seven panels and splice plates applying silicone to the splice plates as before. Leave the last 5 bolts out of the end of the splice plate closest to the wall and the two closest to the cap. Place top cap piece onto top panels, silicone and bolt in place. Install the eight sealing plates at the wall connection. It is imperative that sufficient silicone be used to create an air tight seal.

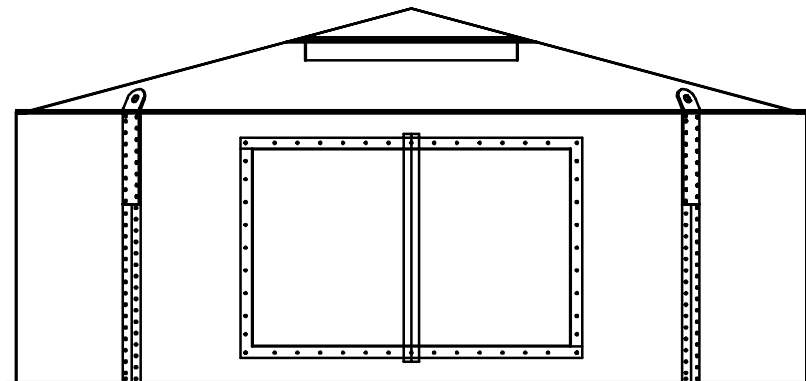
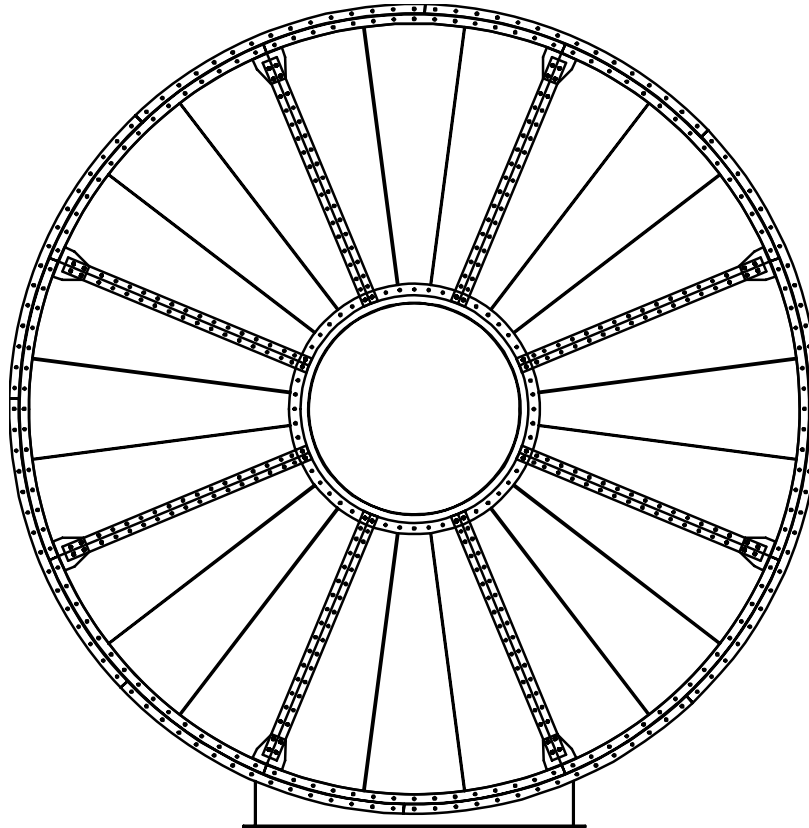

9) Plenum Access Assembly

The plenum access assembly consists of the following items:

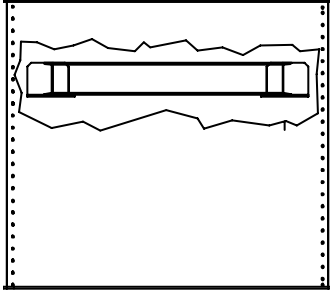

QUANTITY 2 EACH

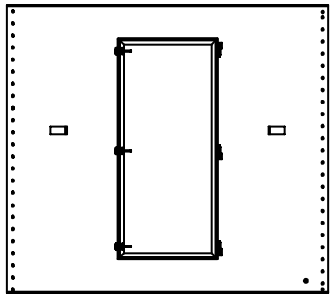

QUANTITY 1 EACH

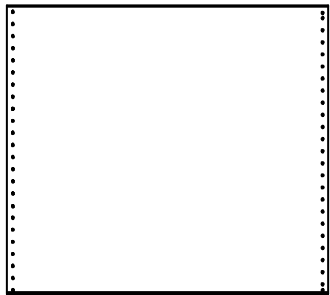

QUANTITY 1 or 3 EACH

Assemble access section walls onto tubesheet. Bolt wall sections together with splice plates as in previous sections. Set section aside.

10) Install Tubesheet & Support Column

At this point the tubesheet can be installed. Large models have a tubesheet support column that allows for leveling the tubesheet. The following procedure should be followed on these models. Lift the tubesheet with the crane and attach the upper portion of the support column to the tubesheet center pipe using the provided 5/8 unc by 6 all-thread bolt (see next page). The holes are slotted so that tubesheet stiffeners will come to rest onto the column plate. Lift the tubesheet with column onto the prepared bag section assembly.

TUBESHEET SUPPORT COLUMN

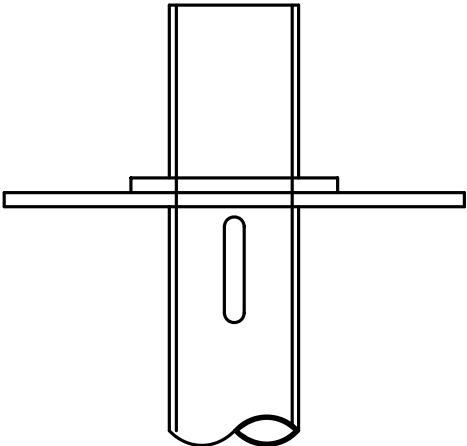
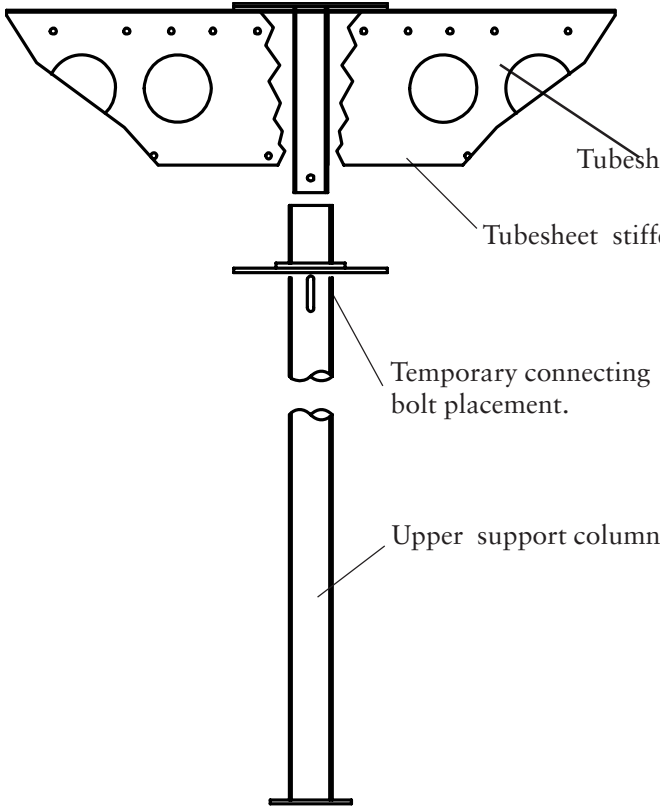

Adjust leveling bolts so they are flush with the nut plate. Slide lower support column onto deflector assembly support stub. After filter section is placed onto inlet and secured connect the upper and lower columns with bolts provided. Use leveling screws to lift tubesheet so that it is level. Insure that the top column plate is firmly against the stiffeners and is not pressing against the temporary connecting bolt.

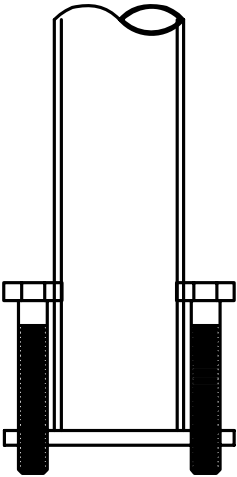
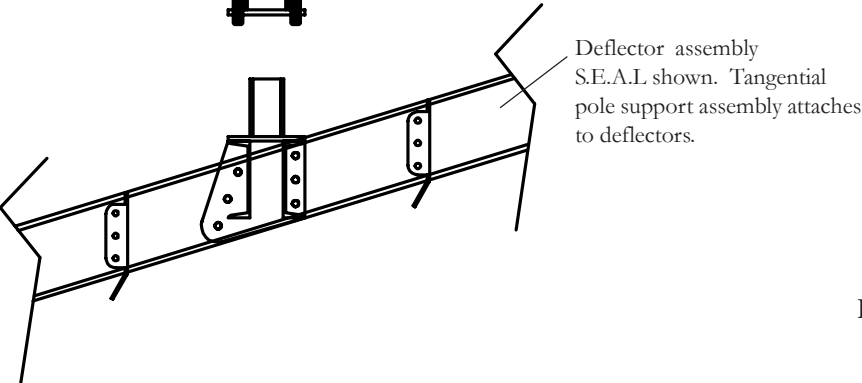
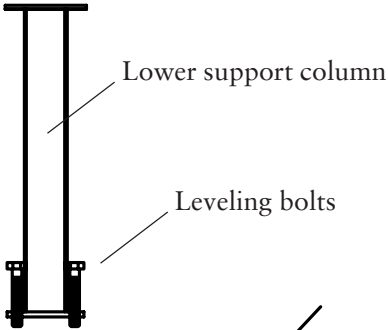

11) Internal Cleaning Assembly

The cleaning assembly consists of the following items:

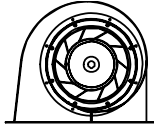

QUANTITY 1 EACH

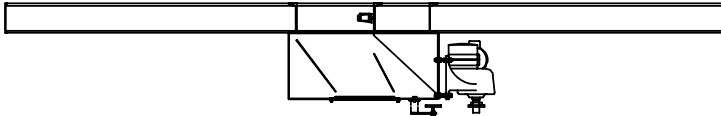

QUANTITY 1 EACH

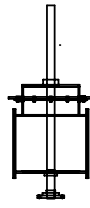

QUANTITY 1 EACH

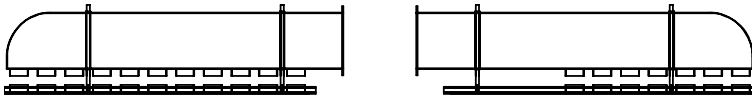

QUANTITY 1 or 2 EA.

Prepare the tubesheet and lift access section into place. Install all bolts and tighten. Lift rotating elbow into place. Slip shaft into bearing on tubesheet. Temporarily support rotating elbow by placing wooden blocks between the tubesheet and the elbow base. Lift the channel frame with seal box into plenum. Align internal bearing with rotating elbow shaft and lower channel frame onto wall mounts. Install all bolts in wall mounts hand tight. Using a level or a framing square on the rotating elbow flange check that the shaft is vertical in all quadrants. Check that elbow is centered in seal box opening. Rotate elbow by hand and check for any obstructions. The urethane seal should drag on elbow pipe. Lift sweep arm(s) into access section and place on tubesheet. Attach the arm(s) to the rotating elbow. Rotate assembly by hand and check for obstructions especially near wall splice plates.

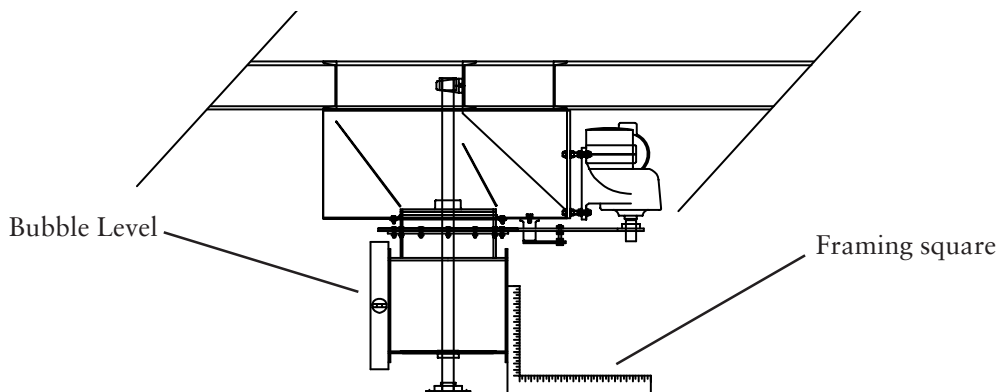

Once shaft is correctly aligned tighten all mount bolts and bearing set screws. Install the drive chain on the sprocket as shown in the diagram below.

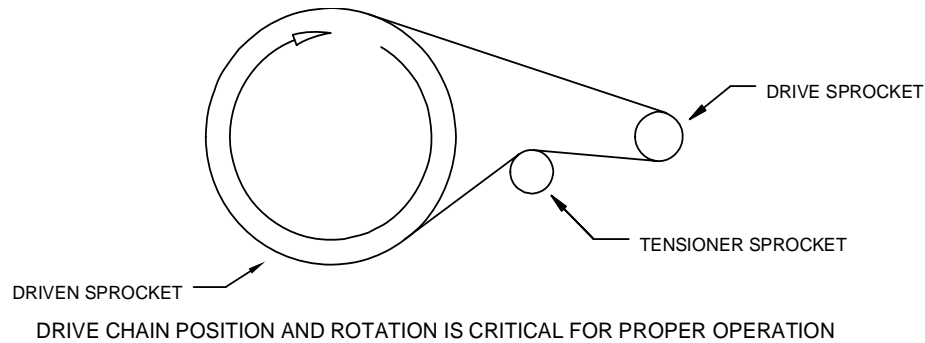

Prepare channels for placement of fan by applying a bead of silicone on the mating surface. Lift fan into place and secure with provided bolts making sure to use the wedge washers on the channels.

12) Install Bags & Cages

At this point it is recommended that the bags and cages be installed because of ease of handling. The bags and cages can be lifted in over the open top of the access section and installed as follows. The filter bags are held in place by a snap band that is incorporated in the bag collar. The closed end of the bag is lowered into the bag section through the tubesheet and the collar is snapped into place. The cage is then lowered into the bag. If the bag section is resting on the ground the cages will not seat completely at this time. However when the filter is lifted into place the cages will have clearance to be seated.

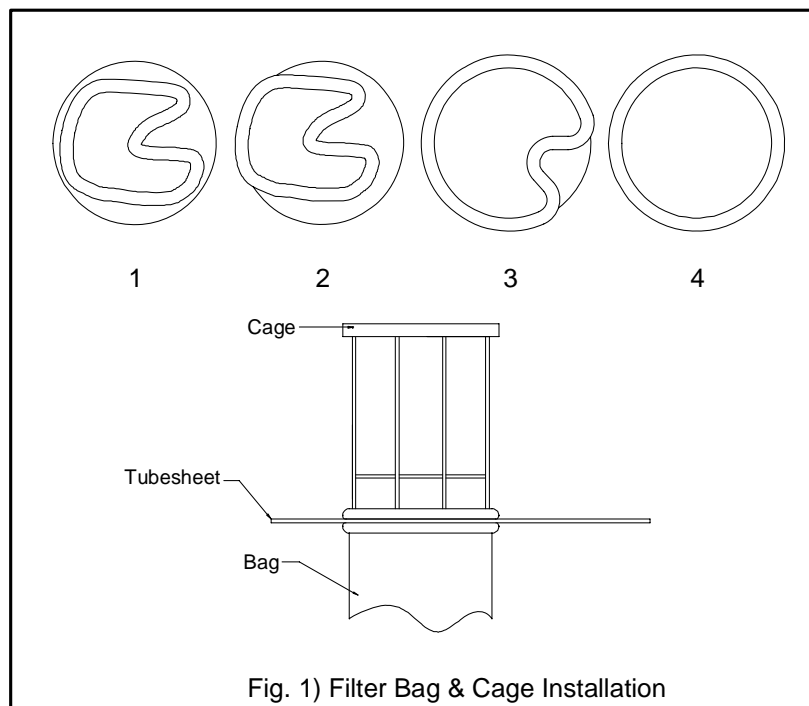

13) Plenum Access and Top Assembly

The plenum access assembly is now ready for the plenum top. Prepare the mating flange with silicone and lift top onto access assembly. Place top in desired orientation with respect to the access door. Install all flange bolts and tighten. Drill a 5/8" dia. hole as shown below and install the magnehelic gauge filter (see next page for details). At this point the filter is ready to be lifted into position.

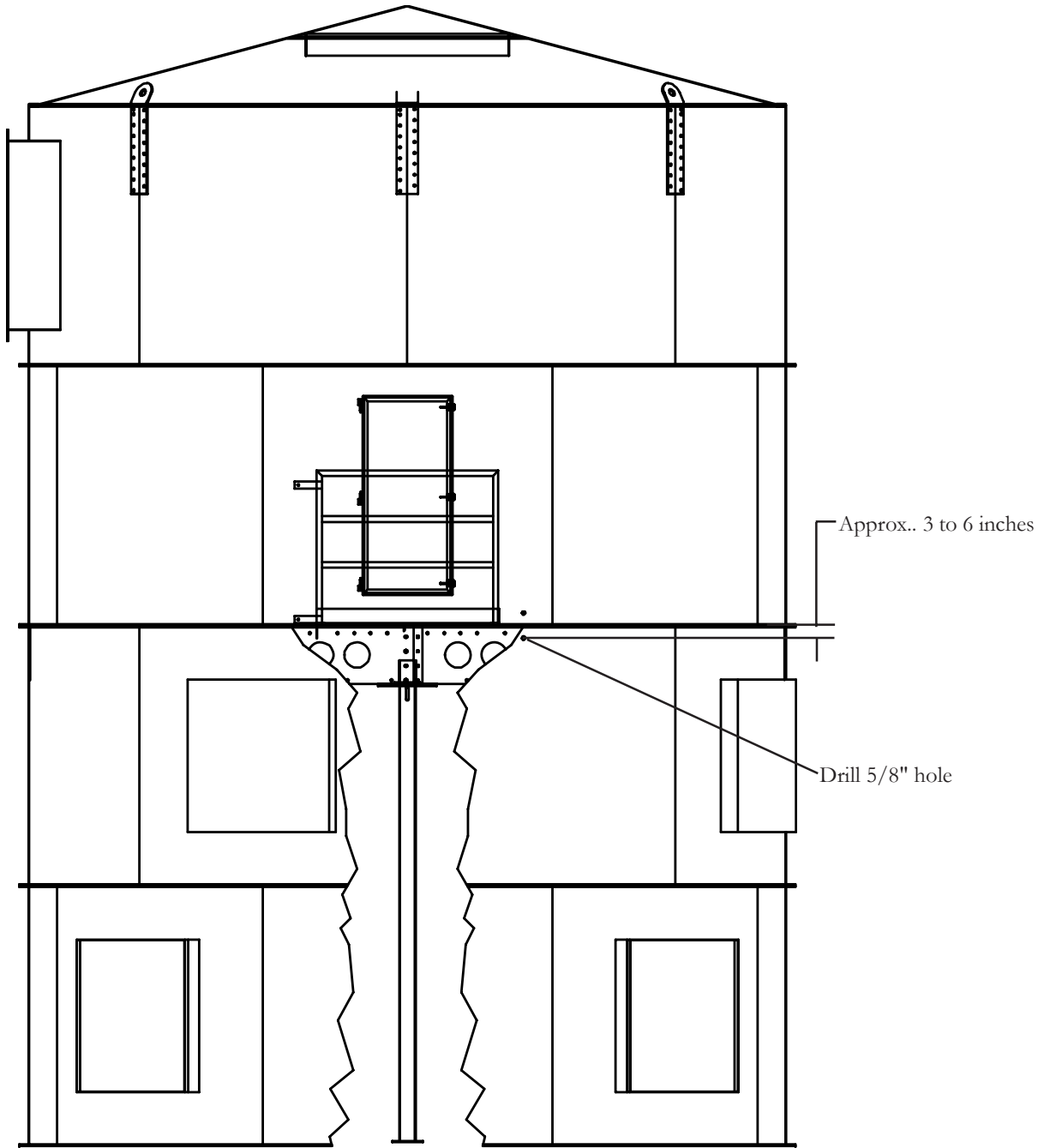

The drawing above shows all the section with seams and features staggered. The actual orientation of each section will vary.

- 1) PACK COTTON FIBERS INTO BULKHEAD FITTING.
- 2) PRESS POLY TUBE INTO FITTING TO SECURE FIBERS

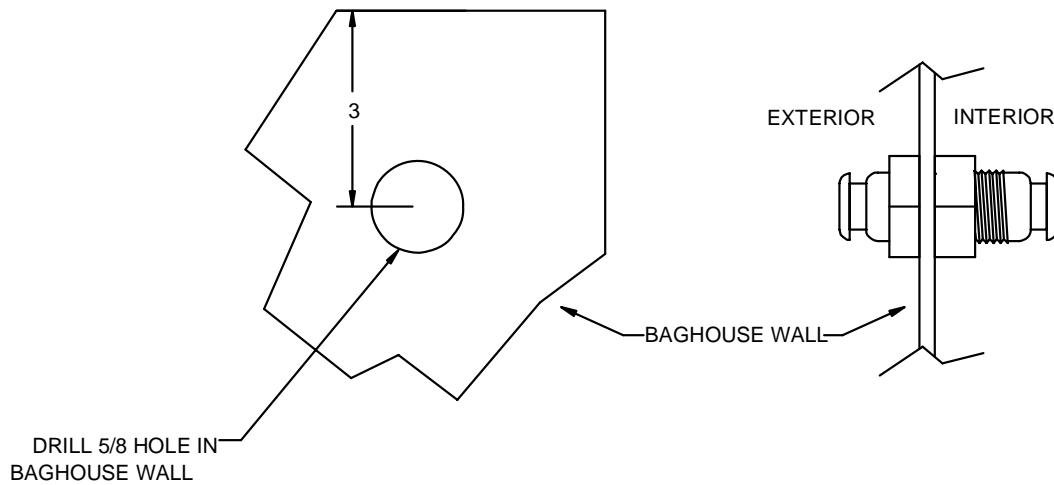
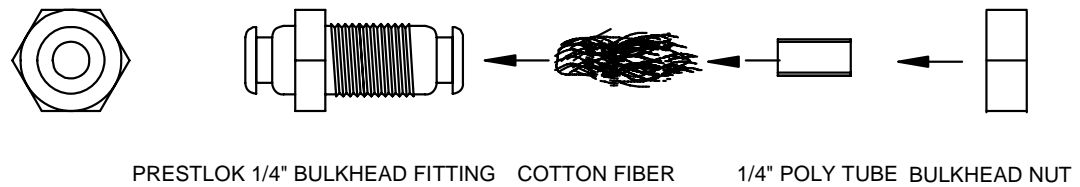

Magnehelic Gauge filter installation

The hole for the magnehelic gauge filter was not drilled at the factory because the actual position of the panel is based on the installation orientation. Therefore it is necessary to drill a 5/8" hole in the bag section panel that is just below the plenum panel with the access door. The interior of the bag section can be accessed by removing one bag and cage closest to the location where the hole is to be drilled.

14) Attach Exhaust Ducting

Depending on the ducting configuration some of the pieces of ducting can be attached to the exhaust flange and lifted at the same time. Any ducting that is attached to the exhaust must be sufficiently supported along its length so as not to damage the filter.

15) Attach Ladders & Platforms

The upper platform mounts to the plenum access section. The lower platform mounts to the main structural support frame. The ladders are bolt together and are marked as being upper or lower.

16) Lift Plenum & Ducting

If not already done in one of the previous two steps prepare the inlet section flange with silicone and lift the top/plenum/bag section onto the filter. Align the flange holes and bolt in place.

17) Install Additional Ducting

After filter is completely erected the rest of the ducting may be connected. It is important to insure that the ducting is adequately supported and that the weight is not entirely on the filter.

18) Install Rotary Airlock

The rotary airlock flange should be prepared with silicone to insure an air tight seal. Lift the airlock into place and bolt into place. Depending on the configuration of the product out fall from the airlock additional support may be required.

19) Install Magnehelic Gauge

The magnehelic gauge is provided with a mounting plate and is typically located near the access ladder at face level. Run two lines of the 1/4" poly tubing provided from the plenum connections down to the gauge. Attach the tubing to the filter at the section flanges with the clips provided to keep it in place.

20) Install Electrical Connections

All electrical connections are the responsibility of the customer. Follow all local and national electrical codes when installing service. Any wiring on the interior of the filter must be rated for explosive environments. Consult your local codes.

21) Inspect Structural Connections

Before placing filter into service it is important that all structural connections be inspected for proper torque. It is recommended that all structural bolts be checked and retightened if necessary.

22) Inspect Electrical & Mechanical Connections

Before placing filter into service it is important that all electrical connections are inspected and approved. The internal fan was checked before shipping however before starting the fan it is recommended that the fan wheel is checked for clearance. This is done by locking out the power source to the fan and then spinning the fan wheel by hand. Listen for any sounds of the wheel rubbing against the inlet cone. If there is no apparent rubbing then bump start the fan and listen for rubbing while fan is at operational speed. If no rubbing is present then the fan set screws should be checked and retightened and the fan is ready for service. It is also important to check that the fan is rotating in the correct direction as indicated by the rotation sticker on the housing.

The gear drive boxes are shipped with the proper amount of oil. However before starting the rotating arm drive check the oil level in the gearbox and place vent cap into proper position. Consult the manufacture's tags that are attached to the gearbox. Visually inspect that there are no obstructions in the drive chain or in the path of the sweep arm assembly. Bump start the drive and note the rotation of the arm. The rotation must be the direction in which the chain tensioner is on the slack side of the drive (see Tubesheet Support Column).

23) Place Filter into Service

The filter should now be ready for service. Please consult the Installation, Operation and Maintenance Manual for further instructions.

The Donaldson Torit Warranty

Donaldson warrants to the original purchaser that the products will be free from defects in materials and workmanship for one (1) years from the date of shipment, if properly installed, maintained and operated under normal conditions. Donaldson does not warrant against damages due to corrosion, abrasion, normal wear and tear, product modification, or product misapplication. Donaldson also makes no warranty whatsoever as to any goods manufactured or supplied by others including electric motors, fans and control components. After Donaldson has been given adequate opportunity to remedy any defects in material or workmanship, Donaldson retains the sole option to accept return of the goods, with freight paid by the purchaser, and to refund the purchase price for the goods after confirming the goods are returned undamaged and in usable condition. Such a refund will be in the full extent of Donaldson's liability. Donaldson shall not be liable for any other costs, expenses or damages whether direct, indirect, special, incidental, consequential or otherwise. The terms of this warranty may be modified only by a special warranty document signed by a Director, General Manager or Vice President of Donaldson. Failure to use genuine Donaldson replacement parts may void this warranty. **THERE EXIST NO OTHER REPRESENTATIONS, WARRANTIES OR GUARANTEES EXCEPT AS STATED IN THIS PARAGRAPH AND ALL OTHER WARRANTIES INCLUDING MERCHANTABILITY AND FITNESS FOR A PARTICULAR PURPOSE, WHETHER EXPRESS OR IMPLIED ARE HEREBY EXPRESSLY EXCLUDED AND DISCLAIMED.**

Parts and Service

For genuine Donaldson Torit replacement filters
and parts, call the Parts Express Line

800-562-0072

www.donaldsontorit.com/lmcwest

For faster service, have unit's model and serial number,
part number, description, and quantity available.



Donaldson
Filtration Solutions

Donaldson Company, Inc.
Industrial Air Filtration
P.O. Box 1299
Minneapolis, MN 55440-1299
donaldsontorit@donaldson.com

Donaldson Company, Inc. is the leading designer and manufacturer of dust, mist, and fume collection equipment used to control industrial-air pollutants. Our equipment is designed to help reduce occupational hazards, lengthen machine life, reduce in-plant maintenance requirements, and improve product quality.