

## Delta P Plus Control

### Installation and Operation Manual

Installation, Operation, and Service Information



This manual is property of the owner. Leave with the unit when set-up and start-up are complete. Donaldson Company reserves the right to change design and specifications without prior notice.

Illustrations are for reference only as actual product may vary.



**This is the safety alert symbol. It is used to alert you to potential personal injury hazards. Obey all safety messages that follow this symbol to avoid possible injury or death.**



## APPLICATION OF DUST CONTROL EQUIPMENT

Combustible materials such as buffing lint, paper, wood, metal dusts, weld fume, or flammable coolants or solvents represent potential fire and/or explosion hazards. Use special care when selecting, installing, and operating all dust, fume, or mist collection equipment when such combustible materials may be present in order to protect workers and property from serious injury or damage due to a fire and/or explosion.

Consult and comply with all National and Local Codes related to fire and/or explosion properties of combustible materials when determining the location and operation of all dust, fume, or mist collection equipment.

When combustible materials are present you must consult with an expert in fire extinguishing and/or explosion protection systems, who is also familiar with the local codes, for support and guidance on the selection and installation of an appropriate fire and/or explosion protection system.

DO NOT allow sparks, cigarettes or other burning objects to enter the hood or duct of any dust, fume, or mist collection equipment as these may initiate a fire or explosion of any combustible materials accumulated in the collector.

Portions of dust, mist, and fume-collection equipment, including the clean- and dirty-air plenums may be considered "OSHA Confined Spaces." Refer to the appropriate OSHA regulations to determine if a specific installation should be considered a confined space and if a permit program is required.

Recirculating filtered air in your facility can be a hazard. Consult with OSHA to ensure compliance with all codes regarding recirculating filtered air.

Improper operation of a dust, fume, or mist control system may contribute to conditions in the work area or facility that could result in severe personal injury and product or property damage. Check that all dust, fume, or mist collection equipment is properly selected, installed, and operated for its intended use.

This manual contains specific precautionary statements relative to worker safety. Read this manual thoroughly and comply as directed. Instruct all personnel on the safe use and maintenance procedures related to this equipment. Discuss any questions on the application, use, or maintenance of this equipment with a Donaldson Torit representative.

For optimum collector performance, use only Donaldson Torit replacement parts.

## Contents

Description.....	1	Delta P Plus Control Calibration .....	5
Operation.....	1	Optional Settings.....	7
Inspection on Arrival.....	2	Troubleshooting.....	9
Electrical Wiring.....	2	Replacement Parts .....	11
Installation.....	2		
Setpoint Adjustment.....	3		
Quick Start Instructions .....	3		
Adjustments .....	3		
Password Protected Settings .....	3		



**DANGER** indicates a hazardous situation which, if not avoided, will result in death or serious injury.



**WARNING** indicates a hazardous situation which, if not avoided, could result in death or serious injury.



**CAUTION**, used with the safety alert symbol, indicates a hazardous situation which, if not avoided, could result in minor or moderate injury.



**NOTICE** is used to address practices not related to personal injury that may result in damage to equipment.

## Data Sheet

Model Number _____	Serial Number _____
Ship Date _____	Installation Date _____
Customer Name _____	
Address _____	
_____	
Filter Type _____	
Accessories _____	
Other _____	

## Description

The Delta P Plus controller continuously monitors and displays differential pressure drop in inches of water or decaPascals on the panel face. When combined with a pulse timer, it can control the collector cleaning mechanism to maintain the differential pressure drop between chosen limits. Three cleaning modes are available along with an alarm function and a 4 – 20 mA signal output.

## Operation

Three cleaning modes, Differential Pressure Cleaning (DFF), Downtime Cleaning (DTC), and Combined Differential and Downtime Cleaning (ALL) are available with this controller and can be individually chosen by the user.

- Differential Pressure Cleaning (DFF) - When the differential pressure drop reaches the controller's HIGH setpoint, the controller closes an output relay initiating the cleaning cycle. When the differential pressure drop reaches the LOW setpoint, the relay opens and the cleaning cycle stops. This sequence continues as long as the collector is running, maintaining the differential pressure drop within a specified range.
- Downtime Cleaning (DTC) – The Delta P Plus controller monitors for the differential pressure drop to exceed the LOW setpoint. (Indicates the blower has been started). When the differential pressure drop later approaches zero (indicating the blower has been shut down), the Delta P Plus engages the cleaning cycle for a pre-selected time. A delay timer allows the blower to come to a stop before the cleaning cycle starts.

The delay timer and cleaning cycle durations are both user adjustable but password protected.

- Combined Differential and Downtime Cleaning (ALL) –The ALL mode combines the two functions described above, maintaining the differential pressure drop in a specified range, then initiating a down-time cleaning cycle when the differential pressure drop approaches zero. The downtime cleaning function can be toggled on or off from the keyboard.

**Note:** The DTC and ALL cleaning modes incorporate compressed air cleaning of the filters when the main collector fan is not running. This may result in collected material “drifting” out the inlet duct of the collector. An isolation valve in the inlet duct of the collector can reduce or eliminate that drifting.

Consideration should be made on the use of the DTC or ALL cleaning mode on small collectors where the relatively low volume of the collector may produce pressure spikes with each pulse of the cleaning cycle. Such pressure spikes may accelerate the fatigue, or damage of ancillary items such as pressure sensors or explosion relief panels.

## Alarm

The alarm is used to indicate that the differential pressure drop has exceeded a preset value. The alarm setpoint is set to a value exceeding the HIGH setpoint used to start the filter cleaning cycle. The purpose of the alarm is to notify the user, via a light on the panel or dry contact output, that the cleaning system cannot reduce the pressure drop possibly due to a cleaning system failure, lack of compressed air, or the end of the filter's useful life. It can also be used to notify the user that the pressure drop has reached a certain value (process related). There is a time delay prior to activating the alarm to prevent nuisance trips of the alarm. The Delta P Plus Control also provides an input connection for a remote alarm reset/disable.

**Note:** Once the differential pressure drop reaches the Alarm value, the relay and LED remain activated until the pressure drop falls below the value set for the HIGH set point or until you deactivate the alarm using a remote reset/disable.

## Inspection on Arrival

1. Inspect unit on delivery.
2. Report any damage to the delivery carrier.
3. Request a written inspection report from the Claims Inspector to substantiate claim.
4. File claims with the delivery carrier.
5. Compare unit received with description of product ordered.
6. Report incomplete shipments to the delivery carrier and your Donaldson Torit representative.

## Electrical Wiring



**WARNING** Electrical service or maintenance work must be performed by a qualified electrician and comply with all applicable national and local codes.

Turn power off and lock out electrical power sources before performing service or maintenance work.

Do not install in classified hazardous atmospheres without an enclosure rated for the application.

All electrical wiring and connections, including electrical grounding, should be made in accordance with the National Electric Code, NFPA No. 70-latest edition.

Check local ordinances for additional requirements that apply.

The appropriate wiring schematic and electrical rating must be used. See unit's rating plate for required voltage.

## Installation



**WARNING** Electrical service or maintenance work must be performed by a qualified electrician and comply with all applicable national and local codes.

Turn power off and lock out electrical power sources before performing service or maintenance work.

Do not install in classified hazardous atmospheres without an enclosure rated for the application.

### NOTICE

The Delta P Plus controller is factory set for 115 V. To operate at 230 V, the jumper settings on the printed circuit board must be changed. See the Optional Settings and Connections section for instructions. Verify voltage selector matches the voltage available prior to energizing the system.

1. Choose a location that permits access to the keypad for adjustments and observation of the pressure drop. Preferably locate the control enclosure near the collector, but if possible mount the control enclosure indoors.
2. Mount the control enclosure using the proper quantity and sized of fasteners.

### NOTICE

Use vibration isolators in high vibration areas.

3. Connect the output contacts to the correct contact terminals of the pulse control timer per the supplied electrical drawing. These connections will start/stop the cleaning cycle.
4. Wire the auxiliary alarm circuit, if desired. This relay output can be used to activate visual or audible alarms provided by others. If not wired, the alarm LED light on the control panel will be the only indication of a fault condition

### NOTICE

Use proper grounding and handling procedures to prevent permanent damage to this device. Handle the printed circuit board by the edges only. Do not touch the socketed E2PROM pins.

5. Wire all remaining auxiliary connections at this time. See the Optional Settings and Connections section for a list of these options.
6. Thirty-five feet of plastic tubing is supplied with the control and must be cut in two sections. Connect one section of tubing from the control enclosure's high-pressure port to the pressure tap on the dirty-air plenum. Connect the remaining section of tubing from the control enclosure's low-pressure port to the pressure tap on the clean-air plenum. Additional tubing can be ordered from your representative.
7. Apply power to the control. Set the high- and low-pressure setpoints to start and stop the cleaning cycle. Set the alarm setpoint to activate the alarm display. See Control Calibration section.

## Setpoint Adjustment

### Quick Start Instructions

1. Press the MENU key, Lo appears. Press the SET key and the current value appears in the display. Use the arrow keys ▲ ▼ to change this value. Press SET again, and the display will blink twice, indicating that the new set point has been accepted.

The Lo setting selects the differential pressure drop value used to stop the pulse cleaning cycle, 2.0" w.g. is a typical initial value.

2. Press the MENU key twice, Hi appears. Press the SET key and the current value appears in the display. Use the arrow keys ▲ ▼ to change this value. Press SET again, and the display will blink twice, indicating that the new set point has been accepted.

The Hi setting selects the differential pressure drop value used to start the pulse cleaning cycle, 4.0" w.g. is a typical initial value.

3. Press the MENU key three times, AL appears. Press the set key and the current value appears in the display. Use the arrow keys ▲ ▼ to change this value. Press SET again, and the display will blink twice, indicating that the new setpoint has been accepted.

The AL setting selects the differential pressure drop value used to close the Alarm relay and turn on the Alarm pilot light on the display.

4. Press the DOWNTIME CLEAN key, and the display will read either On or Off. Pressing the same key again will toggle the reading [On to Off or Off to On]. Press the SET key to lock in your choice.

### Adjustments

1. Pressing the MENU key repeatedly scrolls through the following programming choices:
  - Lo — Low set point
  - Hi — High set point
  - AL — Alarm set point
  - rtn — Return to reading current conditions
  - PAS — Password (for access to secured functions)
3. The SET key shows current value and locks in values after adjustments.
4. The DOWNTIME Clean button toggles the function on and off when available.
5. Not pressing any buttons for 10 seconds allows the control to return to monitoring the filter system.

### Password Protected Settings

To reach the password protected settings, press the MENU key 5 times, the display will show PAS.

Press the SET key, use the up arrow key ▲ to set the value to "4", press set again.

When the display blinks twice, press the MENU key repeatedly until you reach the parameter you wish to change.

Once you have selected a parameter, use the arrow keys ▲ ▼ to change the value within the setting range shown in the table.

Press the SET key to lock in the value.

Parameters	Description	Setting Range	Factory Default	Units	Function
		ALL			ALL - Combines differential pressure (Delta P) based cleaning with downtime cleaning ON/OFF selectable from keypad.
P 6	Mode Select	DTC	ALL	--	DTC - Filters downtime cleaned only, not based on filter Delta P.
		DFF			DFF - Filter cleaning based on Delta P with downtime cleaning not available.
P 7	Display Units 0 = in. w.g. 1 = daPa	0 - 1	0	--	Selects units of measure for the digital display.
P 8	Downtime Start Relay	30 - 99	30	Seconds	Adjustable time lag between the pressure dropping below the value set in parameter P 11 and the start of downtime cleaning.
P 9	Downtime Pressure Enable Relay	30 - 99	30	Seconds	Adjustable time required to be above the value set as the High Set Point (Hi) before the downtime feature is enabled.
P 10	Downtime Cleaning Time	1 - 999	10	Minutes	The amount of time the downtime cleaning will continue once the time set in P 9 expires.*
P 11	Downtime Start Pressure	0 - 9.6 (245)	0.3 (13)	In. Water (daPa)	The falling pressure that triggers the downtime cleaning sequence. **
P 12	Pressure Sensor Input Filtering	0 - 2	1	--	Sets the time used for Delta P value averaging (0 = 250 ms, 1 = 2.5 sec, 2 = 10 sec).
P 13	Reset to Factory Defaults	0 - 1	0	--	0 = No Reset 1 = Reset
P 14	Zero Offset	0 - 1	0	--	0 = No Operations 1 = Offset and Displayed Zero
P 15	Software Version	--	--	--	
P 16	Password	--	--	--	Factory password, no user adjustable items in subsequent parameters.

\* If the downtime cleaning sequence is in progress and the pressure drop indicates a fan restart, the cleaning sequence will end.

\*\* If P 11 is set as equal to or greater than the Lo value, the Lo value will automatically increase 0.2" above the P 11 value.

## Delta P Plus Control Calibration

The only user calibration is the zero adjustment of the display. Due to slight changes in electronic components over time or pressure within the plant environment, the display may read something other than 0.0 while at rest. Use the following procedure to recalibrate the operating system.

1. Turn power to the Delta P Plus Control ON for a minimum of 30-minutes to stabilize the operating temperature.
2. Disconnect the pressure tubing, either leaving it to atmosphere, or connecting the two barbed fittings together with a short length of tubing.
3. Use the Menu key to select PAS.
4. Press SET, then use the arrow keys to display "4", press SET again.
5. Press the MENU key repeatedly until you reach P 14.
6. Press SET, then use the arrow keys to display "1", press SET again.
7. After 10 seconds with no further button action, the display will return to reading the pressure.

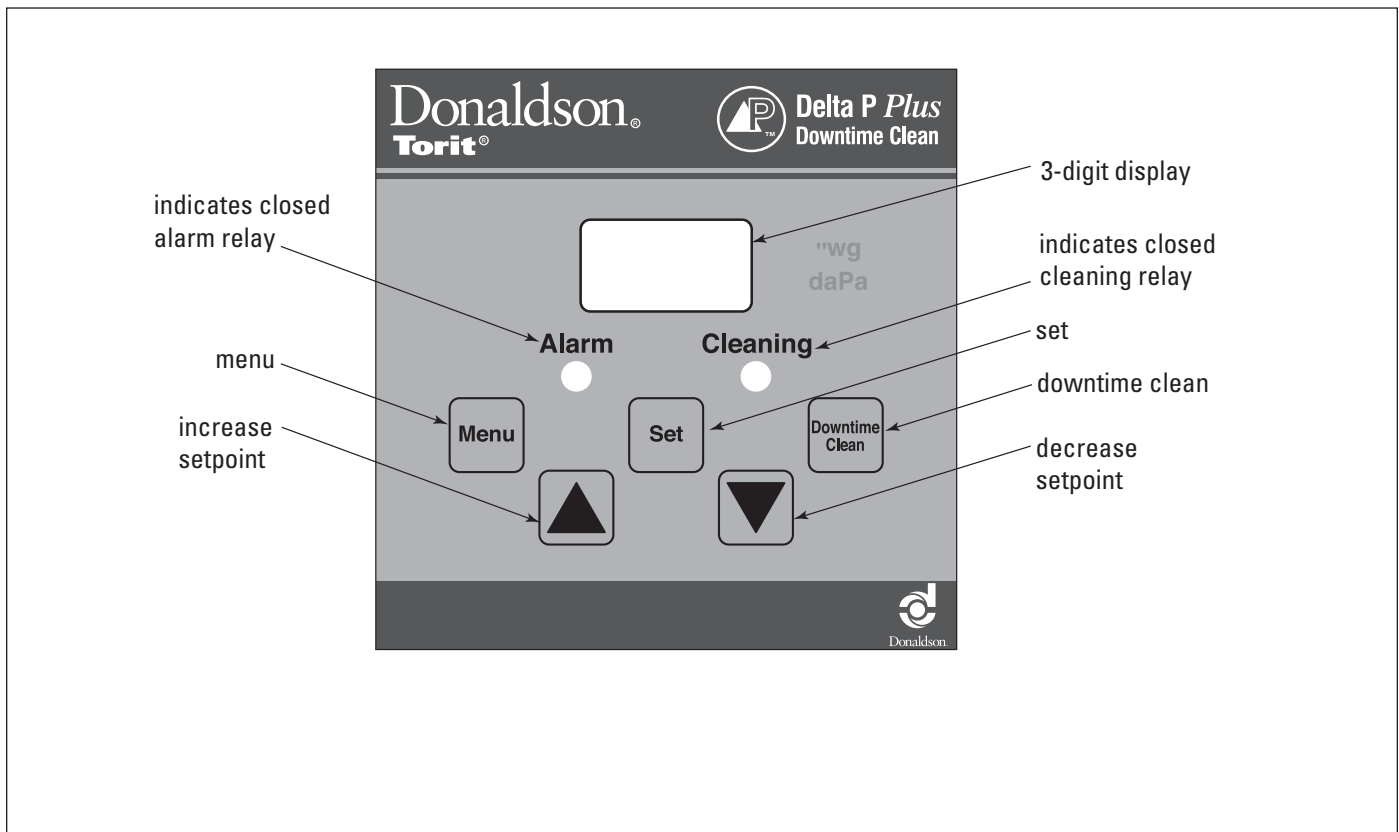

Delta P Plus Control Display Panel

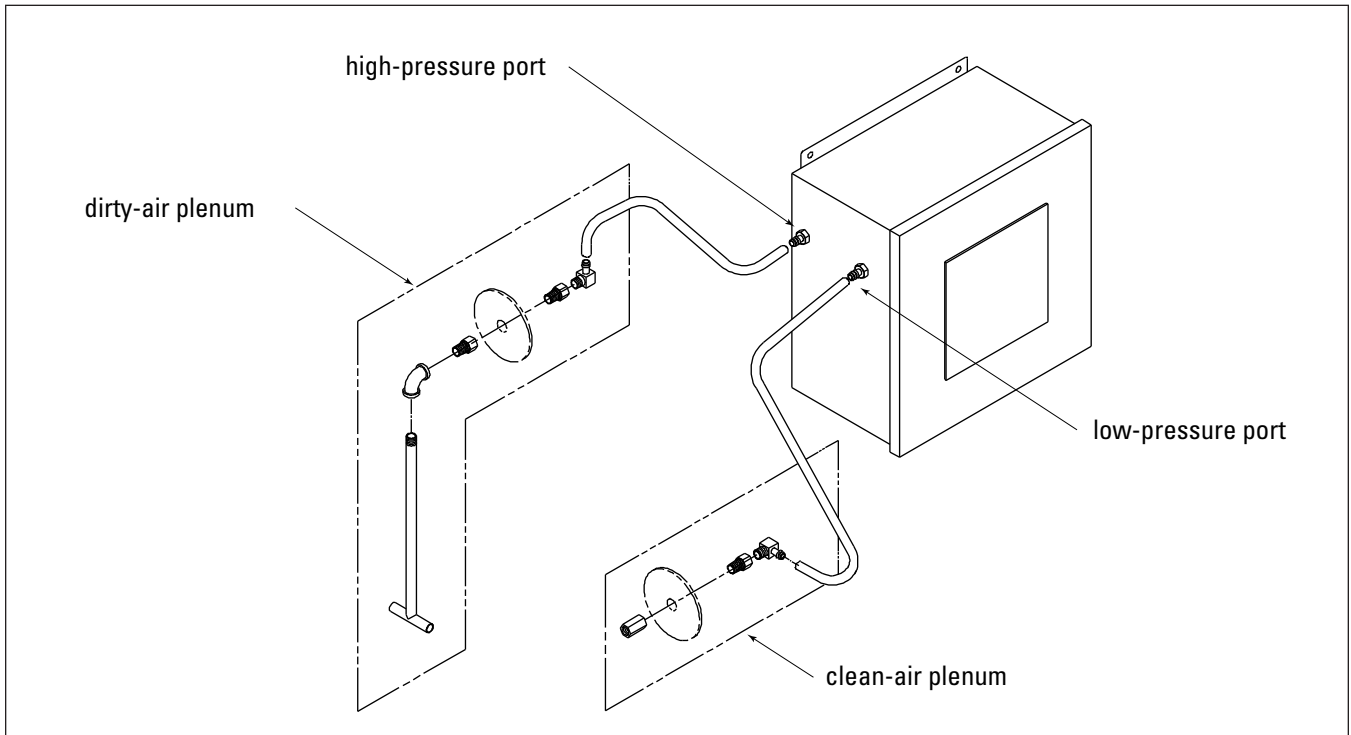

Delta P Plus Control Installation

## Optional Settings

See Printed Circuit Board illustration.

### 230 VAC Power Supply

To operate at 230 VAC, remove two jumpers labeled W1 and W3. Reinsert one of the jumpers in position W2.

### Change from English to Metric (SI) Units

1. Turn power to the Delta P Plus Control ON.
2. Use the Menu key to select PAS.
3. Press SET, then use the arrow keys to display "4", press SET again.
4. Press the MENU key repeatedly until you reach P 6.
5. Press SET, then use the arrow keys to display "0", press SET again.
6. After 10 seconds with no further button action, the display will return to reading the pressure.

### Disable Setpoint Adjustment

To restrict setpoint changes, install a jumper wire across the PROG. DISABLE terminals (3 & 4) on Terminal Block 2, TB2. The current settings will still be displayed, but no changes can be made until the jumper is removed. Interrupting the jumper with a key-operated, normally-closed switch installed in the enclosure door provides temporary access to the setting functions without opening the door.

### External Alarm Reset / Disable (TB2, Terminal 5 & 6)

If desired, wire the ARM RESET terminals (5 & 6) on Terminal Block 2, TB2, to a key-operated, normally-open switch. Closing the switch turns the alarm OFF.

### Internal Alarm Disable (J5)

To disable the alarm internally, remove the jumper on MODE Jumper Block J5, located on the lower-right quadrant of the circuit board. Disabling the alarm relay reduces the alarm function to the ALARM LED visual display only.

### Hi/Lo Control (TB3, Terminals 7, 8, & 9)

Per the wiring diagram supplied with the controller, the Hi/Lo terminals are connected to the pressure switch input on the timer board. In most cases this connection is made at the factory.

Terminal 8 is common, terminal 7 is normally open, and terminal 9 is normally closed.

### Auxiliary Relay Output (TB3, Terminals 10, 11, & 12)

1. If the jumper on the MODE Jumper Block J5 is not installed, the auxiliary relay output will not function.
2. If the jumper is installed in the ALARM mode position, the auxiliary relay output activates based on the setting of the ALARM setpoint.
3. If the jumper is installed in the SLAVE mode position, the auxiliary relay output activates in parallel with the HI/LO CONTROL relay.

Terminal 11 is common, terminal 10 is normally open, and terminal 12 is normally closed.

### Analog Output (TB4, Terminals 13 & 14)

Terminals 13 & 14 on Terminal Block 4, TB4, in the upper-left quadrant of the circuit board, provide a 4 to 20 mA output proportional to the 0-to-maximum span of the pressure sensor. This circuit requires a 500 ohm maximum load.

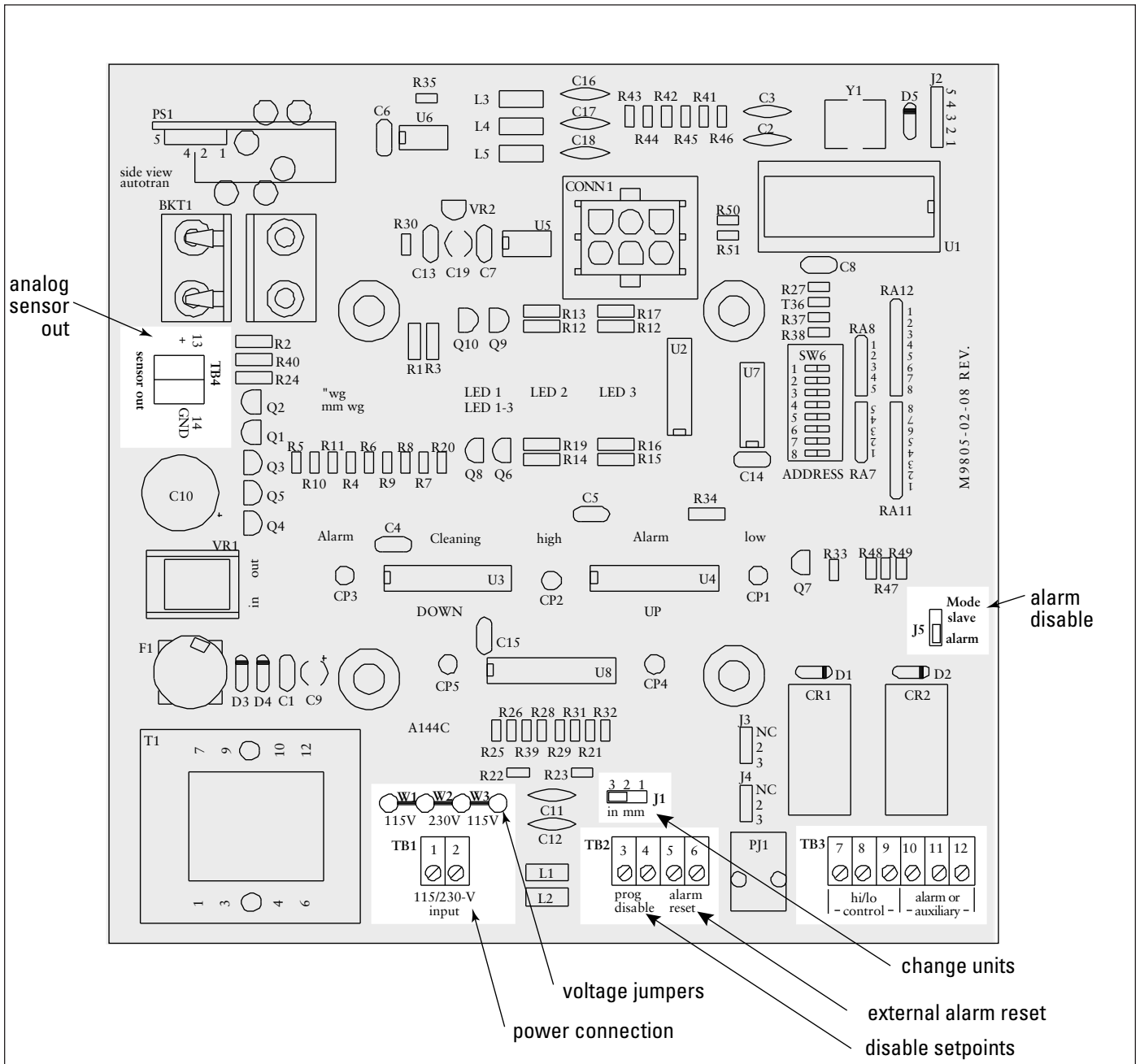

Printed Circuit Board (Optional Settings Location)

## Troubleshooting

Problem	Probable Cause	Remedy
<b>No display on the Delta P Plus Control</b>	No power to the control	Use a voltmeter to check for voltage at Terminal TB1.
	Fuse blown	Check the fuse in the F1 fuse tower. Replace if necessary.
<b>Display on the Delta P Plus control does not read zero when at rest</b>	Out of calibration	Disconnect pressure tubing. See Delta P Plus Control Calibration.
	With collector discharging outside, differential pressure is present from indoor to outdoor	Recalibrate with the pressure tubing attached as described in Delta P Plus Control Calibration.
<b>Display reads “ ___ ”</b>	Pressure out of the allowable range	Check that high and low pressure tubing is attached and not leaking. Use a differential pressure measurement device to verify that the actual pressure does not exceed 20 “wg.
<b>Delta P Plus Control ON, but cleaning system does not start</b>	Not wired to the timing board correctly	Connect the pressure switch on the timer board to Terminals 7 and 8 on TB3.
	Faulty relay	Using a multimeter, test relay for proper closure. Replace if necessary.
	Pressure tubing disconnected, ruptured, or plugged	Check tubing for kinks, breaks, contamination, or loose connections.
<b>Pulse cleaning never stops</b>	Pressure switch terminals on the timer board jumpered	Remove jumper wire on solid-state timer board before wiring to Delta P Plus Control.
	Pressure switch not wired to the timer board correctly	Connect the pressure switch on the timer board to terminal 7 (normally open) and Terminal 8 (common) on TB3.
	High or low setpoint not adjusted for system conditions	Adjust setpoints to current conditions. See Setpoint Adjustment.
	Pressure tubing disconnected, ruptured or plugged.	Check tubing for kinks, breaks, contamination, or loose connections.
<b>Alarm light is ON</b>	Alarm setpoint too low	Adjust to a higher value.
	Excess pressure drop	Check cleaning system and compressed-air supply. Replace filter cartridges if filters do not clean down.
	Pressure tubing disconnected, ruptured, or plugged	Check tubing for kinks, breaks, contamination, or loose connections.

Problem	Probable Cause	Remedy
<b>Delta P Plus arrow keys do not work</b>	Improper operation	Press MENU and choose a parameter, then press SET prior to using the arrow keys.
	Programming keys disabled	Remove the Program Disable jumper from Terminals 3 and 4 on TB2.
<b>Cleaning light is ON, but cleaning system not functioning</b>	Improper wiring	Check wiring between the Delta P Plus Control and the timer board, and between the timer board and solenoid valve coils.
	Defective solenoids	Check all solenoid coil for proper operation.
	Timer board not powered	Check power ON light on timer board's LED display. If not illuminated, check the supply voltage to the timer board. Check the fuse on the timer board. Replace if necessary.
	Timer board defective	If LED is illuminated, observe the output display. Install a temporary jumper across the pressure switch terminals. Output LED's should flash in sequence. Check output using a multimeter set to 150 VAC range, measure from SOL COM to a solenoid output. The needle will deflect when LED flashes for that output if voltage is present. If LEDs do not flash, or if no voltage is present at output terminals during flash, replace the board.
<b>Downtime cleaning too long or too short duration</b>	Parameter setup	Reset the value in Parameter P10.
<b>Pressure display changes value up and down rapidly</b>	Parameter setup	Reset the value in parameter P12.

## Replacement Parts

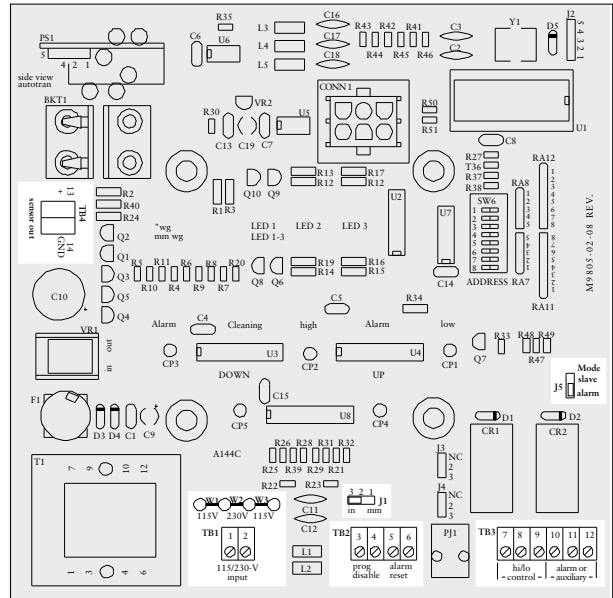
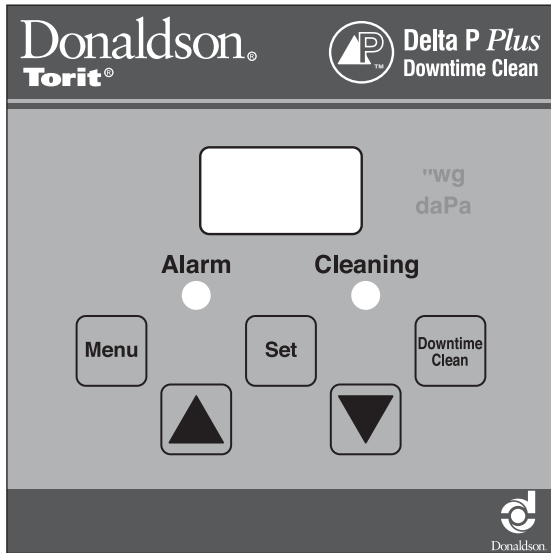

**1** Keypad Label

**2** Printed Circuit Board

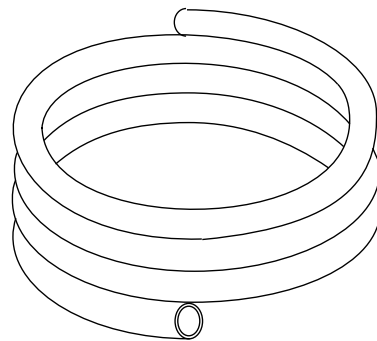

**3** Plastic Tubing

Delta P Plus Control

Item	Part Number	Description	Model
1	7053401	Delta P Plus Control Keypad Label	All
2	7053501	Printed Circuit Board	All
3	2334200	Plastic Tubing, Vinyl, 3/16-in ID, 5/16-in OD	All



## The Donaldson Torit Warranty

Donaldson warrants to the original purchaser that the major structural components of the goods will be free from defects in materials and workmanship for ten (10) years from the date of shipment, if properly installed, maintained and operated under normal conditions. Donaldson warrants all other Donaldson built components and accessories including Donaldson Airlocks, TBI Fans, TRB Fans, Fume Collector products, Donaldson built electrical control components and Donaldson built Afterfilter housings for twelve (12) months from date of shipment. Donaldson warrants Donaldson built filter elements to be free from defects in materials and workmanship for eighteen (18) months from date of shipment. Donaldson does not warrant against damages due to corrosion, abrasion, normal wear and tear, product modification, or product misapplication. Donaldson also makes no warranty whatsoever as to any goods manufactured or supplied by others including electric motors, fans and control components. After Donaldson has been given adequate opportunity to remedy any defects in material or workmanship, Donaldson retains the sole option to accept return of the goods, with freight paid by the purchaser, and to refund the purchase price for the goods after confirming the goods are returned undamaged and in usable condition. Such a refund will be in the full extent of Donaldson's liability. Donaldson shall not be liable for any other costs, expenses or damages whether direct, indirect, special, incidental, consequential or otherwise. The terms of this warranty may be modified only by a special warranty document signed by a Director, General Manager or Vice President of Donaldson. Failure to use genuine Donaldson replacement parts may void this warranty. THERE EXIST NO OTHER REPRESENTATIONS, WARRANTIES OR GUARANTEES EXCEPT AS STATED IN THIS PARAGRAPH AND ALL OTHER WARRANTIES INCLUDING MERCHANTABILITY AND FITNESS FOR A PARTICULAR PURPOSE, WHETHER EXPRESS OR IMPLIED ARE HEREBY EXPRESSLY EXCLUDED AND DISCLAIMED.



**Donaldson**  
FILTRATION SOLUTIONS

### Parts and Service

For genuine Donaldson replacement filters and parts, call the Parts Express Line. For faster service, have unit's model and serial number, quantity, part number, and description available.

**Donaldson Company, Inc.**  
**Industrial Air Filtration**  
**PO Box 1299**  
**Minneapolis, MN 55440-1299**  
**U.S.A.**

**800-365-1331 USA**  
**800-343-3639 within Mexico**

**[donaldsontorit@donaldson.com](mailto:donaldsontorit@donaldson.com)**  
**[donaldsontorit.com](http://donaldsontorit.com)**

Donaldson Company, Inc. is the leading designer and manufacturer of dust, mist, and fume collection equipment used to control industrial-air pollutants. Our equipment is designed to help reduce occupational hazards, lengthen machine life, reduce in-plant maintenance requirements, and improve product quality.

© 2004 Donaldson Company, Inc.  
Printed in USA

IOM AD3425201 (ENG), Revision 4  
May 2011