

Delta P Control

Installation and Operation Manual

Installation, Operation, and Service Information



This manual is property of the owner. Leave with the unit when set-up and start-up are complete. Donaldson Company reserves the right to change design and specifications without prior notice.

Illustrations are for reference only as actual product may vary.



This is the safety alert symbol. It is used to alert you to potential personal injury hazards. Obey all safety messages that follow this symbol to avoid possible injury or death.



APPLICATION OF DUST CONTROL EQUIPMENT

Combustible materials such as buffing lint, paper, wood, metal dusts, weld fume, or flammable coolants or solvents represent potential fire and/or explosion hazards. Use special care when selecting, installing, and operating all dust, fume, or mist collection equipment when such combustible materials may be present in order to protect workers and property from serious injury or damage due to a fire and/or explosion.

Consult and comply with all National and Local Codes related to fire and/or explosion properties of combustible materials when determining the location and operation of all dust, fume, or mist collection equipment.

When combustible materials are present you must consult with an expert in fire extinguishing and/or explosion protection systems, who is also familiar with the local codes, for support and guidance on the selection and installation of an appropriate fire and/or explosion protection system.

DO NOT allow sparks, cigarettes or other burning objects to enter the hood or duct of any dust, fume, or mist collection equipment as these may initiate a fire or explosion of any combustible materials accumulated in the collector.

Portions of dust, mist, and fume-collection equipment, including the clean- and dirty-air plenums may be considered "OSHA Confined Spaces." Refer to the appropriate OSHA regulations to determine if a specific installation should be considered a confined space and if a permit program is required.

Recirculating filtered air in your facility can be a hazard. Consult with OSHA to ensure compliance with all codes regarding recirculating filtered air.

Improper operation of a dust, fume, or mist control system may contribute to conditions in the work area or facility that could result in severe personal injury and product or property damage. Check that all dust, fume, or mist collection equipment is properly selected, installed, and operated for its intended use.

This manual contains specific precautionary statements relative to worker safety. Read this manual thoroughly and comply as directed. Instruct all personnel on the safe use and maintenance procedures related to this equipment. Discuss any questions on the application, use, or maintenance of this equipment with a Donaldson Torit representative.

For optimum collector performance, use only Donaldson Torit replacement parts.

Contents

Description.....	1	Optional Settings.....	5
Operation.....	1	Troubleshooting.....	7
Inspection on Arrival.....	1	Replacement Parts	9
Electrical Wiring.....	1	Service Notes.....	10
Standard Equipment.....	2		
Installation.....	2		
Setpoint Adjustments	3		
Delta P Control Calibration	4		



DANGER indicates a hazardous situation which, if not avoided, will result in death or serious injury.



WARNING indicates a hazardous situation which, if not avoided, could result in death or serious injury.



CAUTION, used with the safety alert symbol, indicates a hazardous situation which, if not avoided, could result in minor or moderate injury.



NOTICE is used to address practices not related to personal injury that may result in damage to equipment.

Data Sheet

Model Number _____	Serial Number _____
Ship Date _____	Installation Date _____
Customer Name _____	
Address _____	

Filter Type _____	
Accessories _____	
Other _____	

Description

The Delta P Control monitors the differential pressure between the clean and dirty air plenums, providing a visual display of the filter condition. When combined with a pulse timer, it controls the pressure drop by turning the cleaning mechanism on and off at the chosen limits. There are three setpoints: High-pressure ON and Low-pressure OFF setpoints control the filter cleaning system, and Alarm provides a relay output to activate an external alarm supplied by others.

Operation

Normal

The Delta P control monitors the pressure in the clean and dirty air plenums while the unit is running. The blower draws air through the filters, creating a pressure drop. The Delta P control measures the pressure drop and provides a visual display in inches water gauge or metric (SI) units.

Filter Cleaning

When the pressure drop across the filters reach the control's HIGH setpoint, the control closes an output relay allowing a timer to trigger the cleaning valves sequentially. When the control senses that the pressure drop has decreased to the LOW setpoint, the relay opens and the cleaning cycle stops. This sequence continues as long as the collector is in use, maintaining the pressure drop within a narrow range.

Alarm

The alarm setpoint is set to a higher setting than used to start the filter cleaning cycle. It indicates situations when the cleaning system cannot reduce the pressure drop due to cleaning system failure, lack of compressed air, or the end of the filter's useful life. There is a time delay prior to setting the alarm to prevent nuisance trips. The Delta P Control also provides an input connection for a remote alarm reset.

Inspection on Arrival

1. Inspect unit on delivery.
2. Report any damage to the delivery carrier.
3. Request a written inspection report from the Claims Inspector to substantiate claim.
4. File claims with the delivery carrier.
5. Compare unit received with description of product ordered.
6. Report incomplete shipments to the delivery carrier and your Donaldson Torit representative.

Electrical Wiring



Electrical service or maintenance work must be performed by a qualified electrician and comply with all applicable national and local codes.

Turn power off and lock out electrical power sources before performing service or maintenance work.

Do not install in classified hazardous atmospheres without an enclosure rated for the application.

All electrical wiring and connections, including electrical grounding, should be made in accordance with the National Electric Code, NFPA No. 70-latest edition.

Check local ordinances for additional requirements that apply.

The appropriate wiring schematic and electrical rating must be used. See unit's rating plate for required voltage.

Standard Equipment

Installation

WARNING

Electrical service or maintenance work must be performed by a qualified electrician and comply with all applicable national and local codes.

Turn power off and lock out electrical power sources before performing service or maintenance work.

Do not install in classified hazardous atmospheres without an enclosure rated for the application.

NOTICE

The Delta P control is factory set for 115-V. To operate at 230-V, the jumper settings on the printed circuit board must be changed. See *Optional Settings*.

1. Choose a location near the unit that permits access to the keypad for adjustments and observation of the pressure drop. If possible, mount the control indoors.
2. Mount the control enclosure using four self-drilling, self-tapping screws.

NOTICE

Use vibration isolators in high vibration areas.

3. Install conduit between the control's enclosure, the solid-state timer, and the solenoid valve enclosure on the collector.
4. Using the wiring diagram provided with the control, make the wiring connections to the Delta P control, the solid-state timer, and the solenoid valves. Make the required connections to the motor starter's low-voltage terminals.

NOTICE

Use proper grounding and handling procedures to prevent permanent damage to this device. Handle the printed circuit board by the edges only. Do not touch the socketed E²PROM pins.

5. Wire the auxiliary alarm circuit, if desired. This relay activates the ALARM light on the control panel and the alarm relay if the pressure drop exceeds the alarm setpoint. The auxiliary relay can be used to activate visual or audible alarms provided by others.
6. Thirty-five feet of plastic tubing is supplied with the control and must be cut in two sections. Connect one section of tubing from the control enclosure's high-pressure port to the pressure tap on the dirty-air plenum. Connect the remaining section of tubing from the control enclosure's low-pressure port to the pressure tap on the clean-air plenum. Additional tubing can be ordered from your representative.
7. Place the program wire on the solid-state timer board pin to match the number of solenoid-valve connections used.
8. Apply power to the control. Set the high- and low-pressure setpoints to start and stop the cleaning process. Set the alarm setpoint to activate the alarm display. See *Control Calibration*.

Setpoint Adjustments

Low Setpoint

Press and hold the LOW SET key while using the increase or decrease arrow keys until the desired Low Setpoint is displayed. If the desired setting cannot be reached, increase the High Setpoint to a value higher than the intended Low Setpoint and readjust the Low Setpoint.

High Setpoint

Press and hold the HIGH SET key while using the increase or decrease arrow keys until the desired High Setpoint is displayed. If the desired setting cannot be reached, increase the Alarm Setpoint to a value higher than the intended High Setpoint and readjust the High Setpoint.

Alarm Setpoint

Press and hold the ALARM SET key while using the increase or decrease arrow keys until the desired Alarm Setpoint is displayed. If the desired setting cannot be reached, decrease the High Setpoint to a value lower than the intended Alarm Setpoint and readjust the Alarm Setpoint.

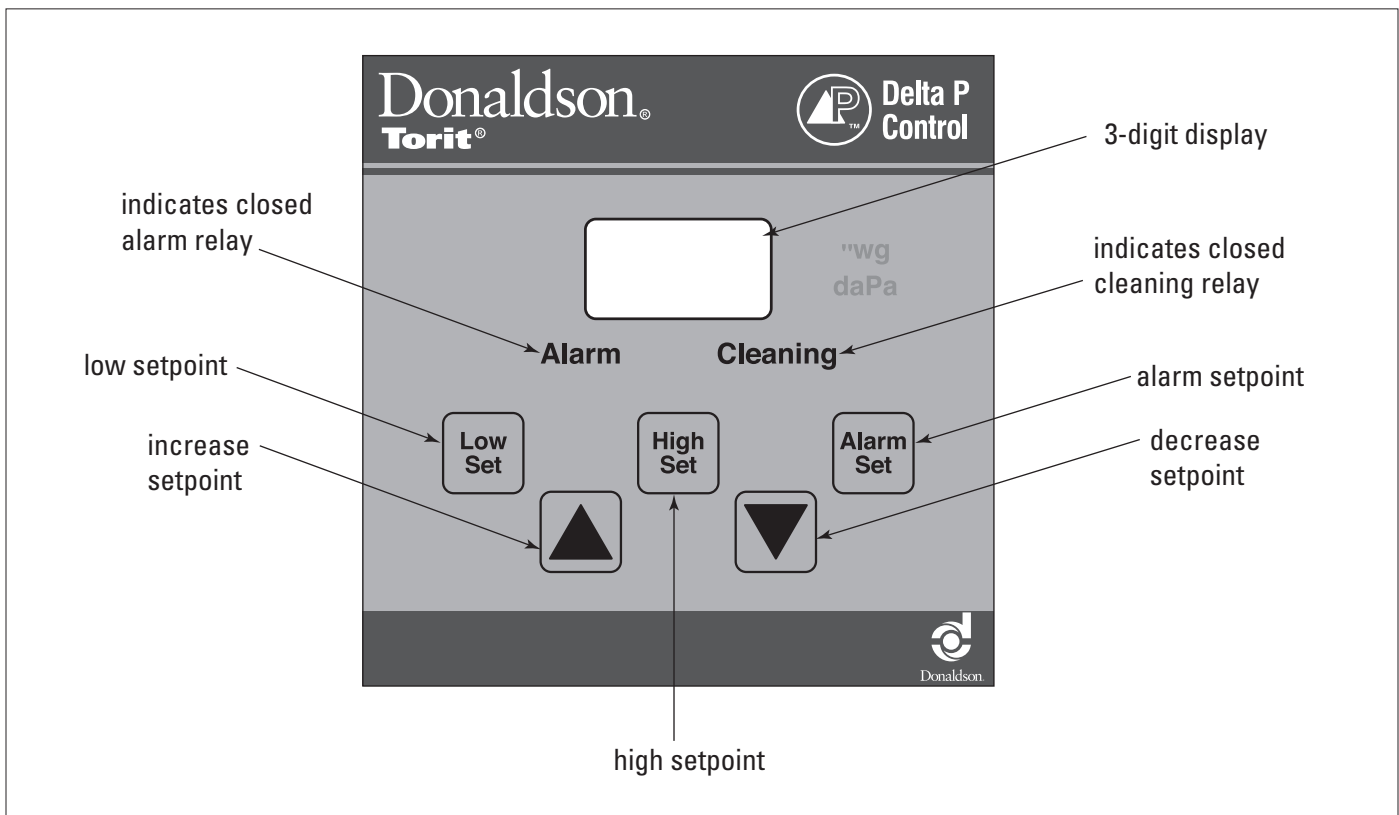

Delta P Control Display

Delta P Control Calibration

The only user calibration is the zero adjustment of the display. Due to slight changes in electronic components over time, or pressure differentials within the plant environment, the display may read something other than 0.0 while at rest. Use the following procedure to recalibrate the operating system.

1. Turn power to the Delta P Control ON for a minimum of 30-minutes to stabilize the operating temperature.
2. Turn power to the control OFF.
3. Press and hold the LOW SET, HIGH SET, and ALARM SET keys while turning power to the control back ON. Continue holding the keys as the control goes through its power-up sequence. The number 8 is displayed in each digit, and then the display reads 0.0.
4. Release the three keys. The new calibration is automatically stored in memory.

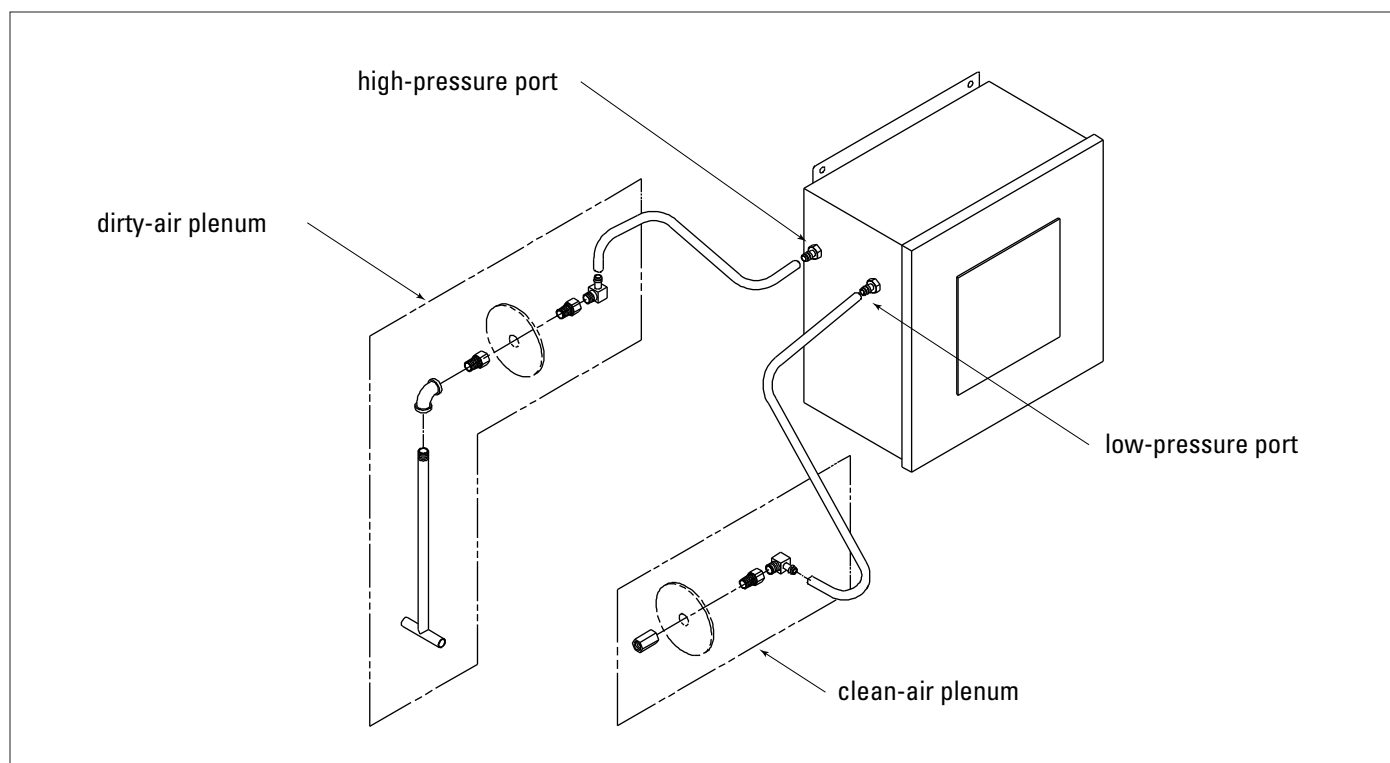

Delta P Control Installation

Optional Settings

230-V Power Supply

To operate at 230-V, remove two jumpers labeled W1 and W3. Reinsert one of the jumpers in position W2.

Change from English to Metric (SI) Units

On the J1 jumper block located above the PROG DISABLE terminals, move the jumper from the center and left pins 2 and 3, to the center and right pins 1 and 2.

Disable Setpoint Adjustment

To restrict setpoint changes, install a jumper wire across the PROG DISABLE terminals on Terminal Block 2, TB2. The current settings can be displayed, but no changes can be made until the jumper is removed. Interrupting the jumper with a key-operated, normally-closed switch installed in the enclosure door provides temporary access to the setting functions without opening the door.

External Alarm Reset

Wire the ARM RESET terminals on Terminal Block 2, TB2, to a key-operated, normally-open switch. Closing the switch turns the alarm OFF. If alarm conditions still exist, the alarm relay reactivates in 10 seconds.

Alarm Disable

Remove the jumper on Jumper Block J5 located on the lower-right quadrant of the circuit board, from the ALARM mode position.

1. Reinstall the jumper in the SLAVE mode position to operate the AUXILIARY relay in parallel with the HI/LO CONTROL relay.
2. The AUXILIARY relay will not function if no jumper is installed.

Note: Disabling the alarm relay reduces the alarm function to visual display only.

Analog Output (TB4, Terminals 13 & 14)

Terminals 13 & 14 on Terminal Block 4, TB4, in the upper-left quadrant of the circuit board, provide a 4 to 20 mA output proportional to the 0-to-maximum span of the pressure sensor. This circuit requires a 500 ohm maximum load.

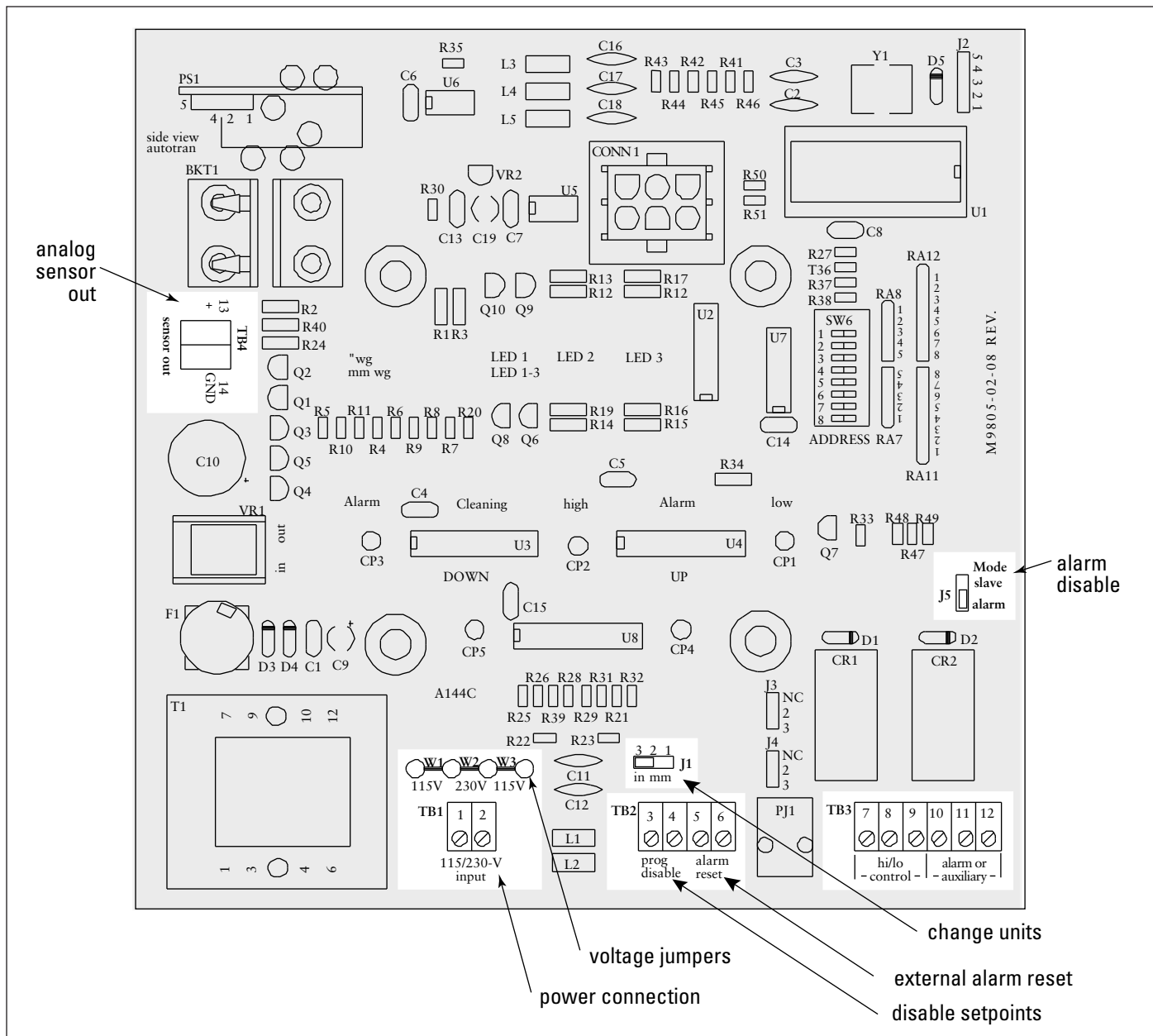

Printed Circuit Board (Optional Settings Location)

Troubleshooting

Problem	Probable Cause	Remedy
No display on the Delta P Control	No power to the control	Use a voltmeter to check for voltage at Terminal TB1.
	Fuse blown	Check the fuse in the F1 fuse tower. Replace if necessary.
Display on the Delta P Control does not read zero when at rest	Out of calibration	Disconnect pressure tubing. See Delta P Control Calibration section.
	With collector discharging outside, differential pressure is present from indoor to outdoor	Recalibrate with the pressure tubing attached as described in the Delta P Control Calibration section.
Display reads “_ _ _”	Pressure out of the allowable range	Check that high and low pressure tubing is attached and not leaking. Use a differential pressure measurement device to verify that the actual pressure does not exceed 20 " wg.
Delta P Control ON, but cleaning system does not start	Not wired to the timing board correctly	Connect the pressure switch on the timer board to Terminals 7 and 8 on TB3.
	Faulty relay	Using a multimeter, test relay for proper closure. Replace if necessary.
	Pressure tubing disconnected, ruptured, or plugged	Check tubing for kinks, breaks, contamination, or loose connections.
Pulse cleaning never stops	Pressure switch terminals on the timer board jumpered	Remove jumper wire on solid-state timer board before wiring to Delta P Control.
	Pressure switch not wired to the timer board correctly	Connect the pressure switch on the timer board to terminal 7 (normally open) and Terminal 8 (common) on TB3.
	High or low setpoint not adjusted for system conditions	Adjust setpoints to current conditions. See Setpoint Adjustment section.
	Pressure tubing disconnected, ruptured, or plugged.	Check tubing for kinks, breaks, contamination, or loose connections.

Problem	Probable Cause	Remedy
Alarm light is ON	Alarm setpoint too low	Adjust to a higher value.
	Excess pressure drop	Check cleaning system and compressed-air supply. Replace filters if filters do not clean down.
	Pressure tubing disconnected, ruptured, or plugged	Check tubing for kinks, breaks, contamination, or loose connections.
Delta P arrow keys do not work	Improper operation	Press and hold one of the three setpoint keys to use arrow keys.
	Programming keys disabled	Remove the Program Disable jumper from Terminals 3 and 4 on TB2.
Cleaning light is ON, but cleaning system not functioning	Improper wiring	Check wiring between the Delta P Control and the timer board, and between the timer board and solenoid valve coils.
	Defective solenoids	Check all solenoid coil for proper operation.
	Timer board not powered	Check power ON light on timer board's LED display. If not illuminated, check the supply voltage to the timer board. Check the fuse on the timer board. Replace if necessary.
	Timer board defective	If LED is illuminated, observe the output display. Install a temporary jumper across the pressure switch terminals. Output levels should flash in sequence. Check output using a multimeter set to 150-Volt AC range. Measure from SOL COM to a solenoid output. The needle will deflect when LED flashes for that output if voltage is present. If LEDs do not flash, or if no voltage is present at output terminals during flash, replace the board.

Replacement Parts



1 Keypad Label

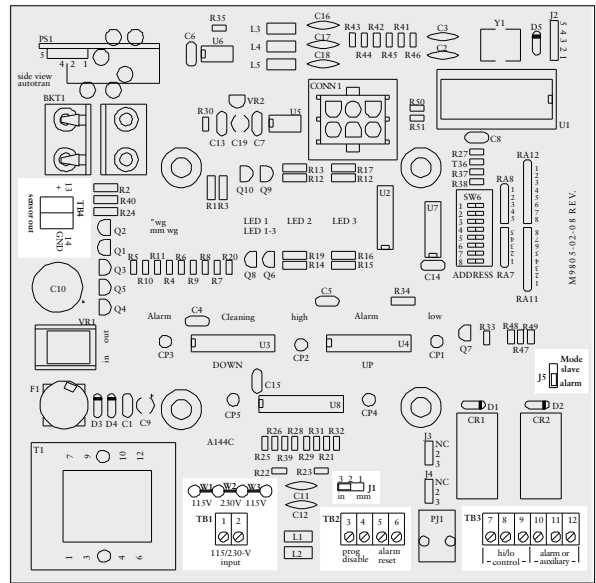

2 Printed Circuit Board

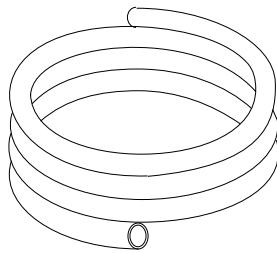

3 Plastic Tubing

Delta P Control

Item	Part Number	Description	Model
1	7536001	Delta P Control Keypad Label	All
2	7536101	Printed Circuit Board	All
3	2334200	Plastic Tubing, Vinyl, 3/16-in ID, 5/16-in OD	All

The Donaldson Torit Warranty

Donaldson warrants to the original purchaser that the major structural components of the goods will be free from defects in materials and workmanship for ten (10) years from the date of shipment, if properly installed, maintained and operated under normal conditions. Donaldson warrants all other Donaldson built components and accessories including Donaldson Airlocks, TBI Fans, TRB Fans, Fume Collector products, Donaldson built electrical control components and Donaldson built Afterfilter housings for twelve (12) months from date of shipment. Donaldson warrants Donaldson built filter elements to be free from defects in materials and workmanship for eighteen (18) months from date of shipment. Donaldson does not warrant against damages due to corrosion, abrasion, normal wear and tear, product modification, or product misapplication. Donaldson also makes no warranty whatsoever as to any goods manufactured or supplied by others including electric motors, fans and control components. After Donaldson has been given adequate opportunity to remedy any defects in material or workmanship, Donaldson retains the sole option to accept return of the goods, with freight paid by the purchaser, and to refund the purchase price for the goods after confirming the goods are returned undamaged and in usable condition. Such a refund will be in the full extent of Donaldson's liability. Donaldson shall not be liable for any other costs, expenses or damages whether direct, indirect, special, incidental, consequential or otherwise. The terms of this warranty may be modified only by a special warranty document signed by a Director, General Manager or Vice President of Donaldson. Failure to use genuine Donaldson replacement parts may void this warranty. THERE EXIST NO OTHER REPRESENTATIONS, WARRANTIES OR GUARANTEES EXCEPT AS STATED IN THIS PARAGRAPH AND ALL OTHER WARRANTIES INCLUDING MERCHANTABILITY AND FITNESS FOR A PARTICULAR PURPOSE, WHETHER EXPRESS OR IMPLIED ARE HEREBY EXPRESSLY EXCLUDED AND DISCLAIMED.



Donaldson
FILTRATION SOLUTIONS

Parts and Service

For genuine Donaldson replacement filters and parts, call the Parts Express Line. For faster service, have unit's model and serial number, quantity, part number, and description available.

Donaldson Company, Inc.
Industrial Air Filtration
P.O. Box 1299
Minneapolis, MN 55440-1299
donaldsontorit@donaldson.com

800-365-1331 USA
800-343-3936 within Mexico
www.donaldsontorit.com

Donaldson Company, Inc. is the leading designer and manufacturer of dust, mist, and fume collection equipment used to control industrial-air pollutants. Our equipment is designed to help reduce occupational hazards, lengthen machine life, reduce in-plant maintenance requirements, and improve product quality.

© 2002 Donaldson Company, Inc.
Printed in USA

IOM 7546301 (ENG), Revision 8
May 2011