

# Installation and Operation Manual

## Downflo<sup>®</sup> II Models DFT 2-4 and DFT 3-6

Units Built After July 2003

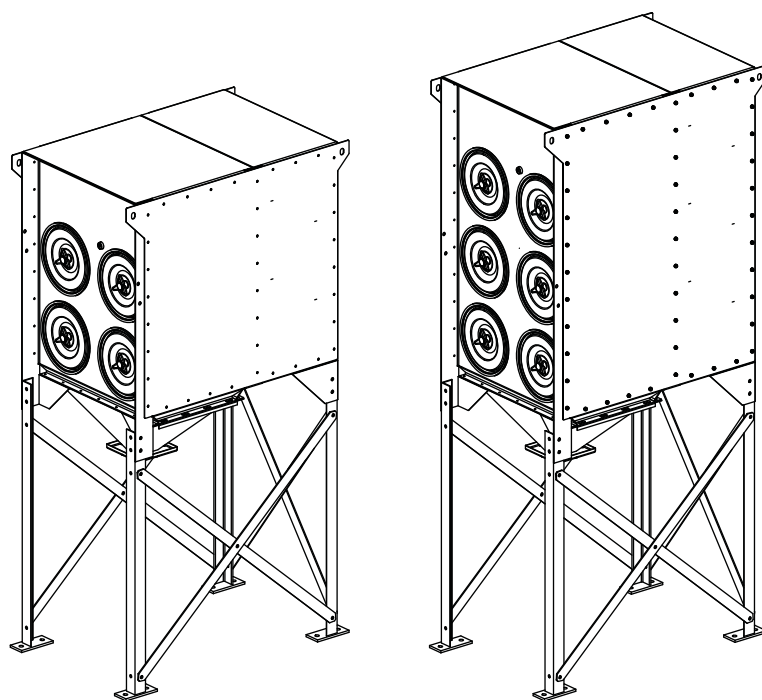

DFT 2-4

DFT 3-6



Throughout this manual statements indicating precautions necessary to avoid equipment failure are referenced in a **Note**. Statements indicating potential hazards that could result in *personal injury* or *property damage* are referenced in a **Caution!** box.

This manual is property of the owner. Leave with the unit when set-up and start-up are complete. Donaldson Company reserves the right to change design and specifications without prior notice.



## Caution!

### Application of Dust Control Equipment

- Combustible materials such as buffing lint, paper, wood, aluminum or steel dust, weld fume, or flammable solvents represent fire or explosion hazards. Use special care when selecting and operating all dust or fume collection equipment when combustible materials are present to protect workers and property from damage due to fire and/or explosion. Consult and comply with National and Local Codes relating to fire or explosion and all other appropriate codes when determining the location and operation of dust or fume collection equipment.
- When combustible materials are present, consult with an installer of fire extinguishing systems familiar with these types of fire hazards and local fire codes for recommendations and installation of fire extinguishing and explosion protection systems. Donaldson dust collection equipment is not equipped with fire extinguishing or explosion protection systems.
- DO NOT allow sparks, cigarettes or other burning objects to enter the hood or duct of any dust or fume control equipment as these may initiate a fire or explosion.
- For optimum collector performance, use only Donaldson replacement parts.

**Warning** – Improper operation of a dust control system may contribute to conditions in the work area or facility that could result in severe personal injury and product or property damage. Check that all collection equipment is properly selected and sized for the intended use.

## Contents

Description .....	4	Preliminary Start-Up Check .....	20
Purpose and Intended Use .....	4	Optional Equipment .....	21
Operation .....	5	5-Gallon Pail Pack .....	21
Inspection on Arrival .....	6	55-Gallon Drum Pack .....	22
Installation Codes and Procedures .....	6	Magnehelic® Gauge .....	24
Installation .....	6	Photohelic® Gauge .....	26
Site Selection .....	6	Delta P Control .....	28
Unit Location .....	6	Damper Installation .....	31
Electrical Wiring .....	7	Exhaust Grid Installation .....	32
Rigging Instructions .....	7	Plenum Silencer .....	32
Hoisting Information .....	7	Exhaust Silencer .....	33
Standard Equipment .....	8	Abrasion-Resistant Inlet Collar .....	33
Hopper Installation .....	8	HEPA or ASHRAE Afterfilter Installation ..	34
Leg Installation .....	9	Cold Climate Kit .....	35
Power Pack Installation .....	10	Drum Sentry™, Drum-Full Indicator .....	36
Electrical Connection .....	12	Sprinkler Installation .....	38
Solid-State Timer Installation .....	12	Explosion Vents .....	38
Checker™ board Control Panel .....	15	Service Information .....	39
Compressed Air Installation .....	18	Operational Checklist .....	39
		Filter Installation and Replacement .....	39
		Dust Disposal .....	40
		Compressed Air Components .....	40
		Troubleshooting .....	41
		Service Notes .....	45
		Warranty .....	48



This manual contains specific precautionary statements relative to worker safety. Read thoroughly and comply as directed. Discuss the use and application of this equipment with a Donaldson representative. Instruct all personnel on safe use and maintenance procedures.

Magnehelic® and Photohelic® are registered trademarks of Dwyer Instruments, Inc.

## Data Sheet

Model Number _____	Serial Number _____
Ship Date _____	Installation Date _____
Customer Name _____	
Address _____	
_____	
Filter Type _____	
Accessories _____	
Other _____	

## Description

The Downflo® II dust collector is a continuous-duty collector with cartridge-style filters. The downward airflow design delivers high filtration efficiency while using less energy. Continuous-duty means no downtime. The filters are pulse-cleaned in sequence, one at a time, without turning the unit off.

Designed to increase the versatility of the unit, standard options include abrasion-resistant inlets, exhaust dampers, and plenum silencers.

## Purpose and Intended Use

Downflo II collectors are widely used on nuisance dust where the load to the collector is less than two grains per square foot. Some typical applications include abrasive blasting, grinding, pharmaceuticals, powder paint applications, sand handling, and welding. Choose the correct filter cartridge for the application and type of dust collected.

- For fibrous dust, use a cartridge with an open-pleat design, such as Fibra-Web®.
- Operations involving high temperature and humidity require special attention. Temperature, moisture content, and chemistry issues may exist, and custom design modifications to the collector may be required.
- Hygroscopic dust such as fertilizer, salt, and sugar should be handled under a controlled, low relative humidity environment. In addition, use a cartridge with a synthetic substrate, such as Fibra-Web.
- For flammable or explosive dust, use cartridges with metal end caps for more effective grounding.
- Applications with high hydrocarbon or oil content should be avoided as these contaminants will load and plug the cartridge to the point that it cannot be sufficiently cleaned.



### Caution!

- Misuse or modification of this equipment may result in personal injury.
- Do not misuse or modify.



### Caution!

- Combustible materials such as buffing lint, paper, wood, aluminum or steel dust, weld fume, and flammable solvents represent fire or explosion hazards.
- Use special care when selecting and operating all collection equipment when combustible materials are present to protect workers and property from damage due to fire and/or explosion.
- Consult and comply with National and Local Codes relating to fire or explosion, and all other appropriate codes when determining the location and operation of dust collection equipment.
- Donaldson equipment is not equipped with fire extinguishing or explosion protection systems.

## Operation

During normal operation, dust-laden air enters the unit through the dirty-air inlet. Airflow is directed downward through the collector and heavier particulate falls directly into the hopper. The cartridges remove fine particulate and clean, filtered air passes through the cartridge to the clean-air plenum and discharges through the clean-air outlet.

Filter cleaning is completed using pulse-jet technology. A solenoid and diaphragm valve aligned to each filter provides the pulse cleaning. The cleaning sequence starts at the top filter and continues down. Remove, inspect, or change the cartridges from outside the unit by removing the filter access cover and sliding the filters out.

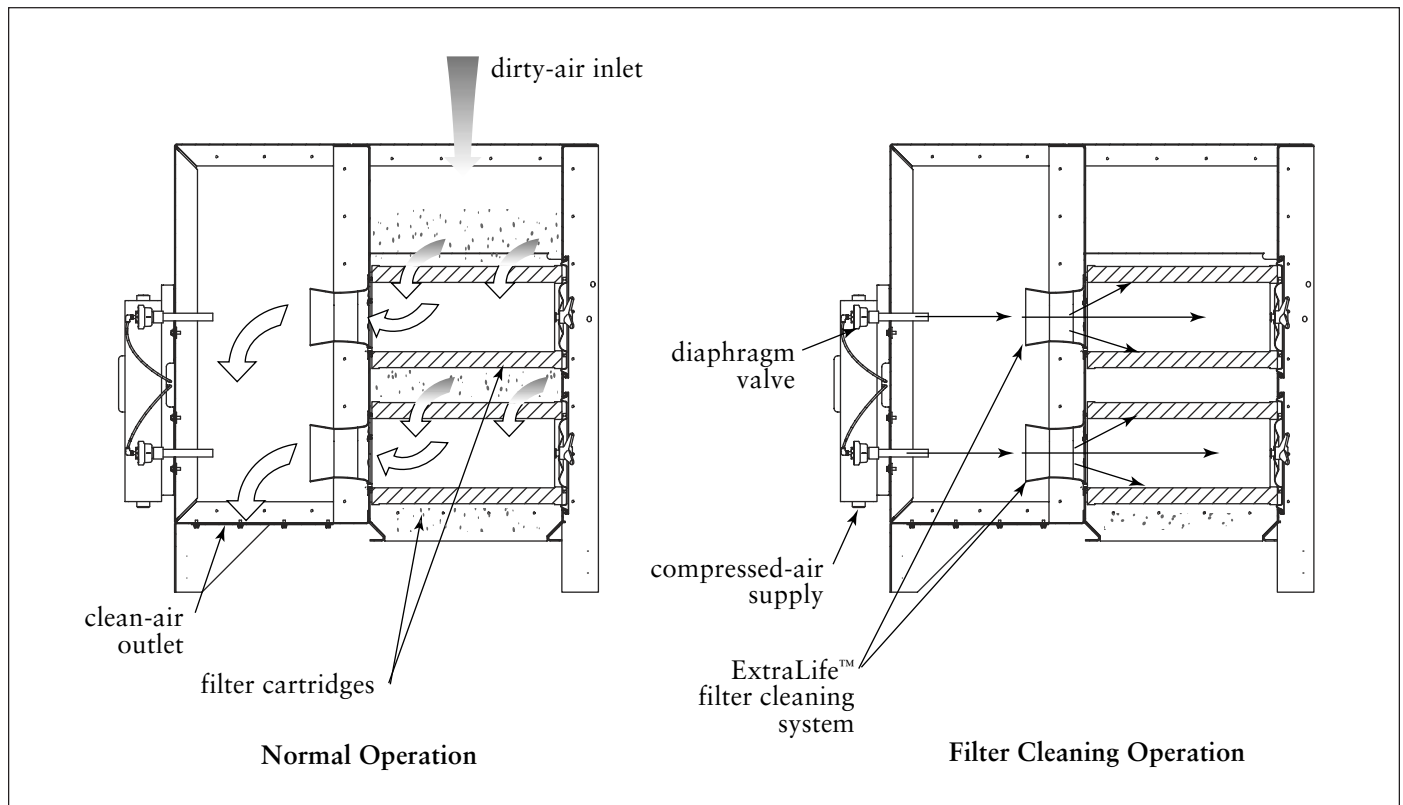

*Unit Operation*

## Inspection on Arrival

1. Inspect unit on delivery.
2. Report any damage to the delivery carrier.
3. Request a written inspection report from the Claims Inspector to substantiate claim.
4. File claims with the delivery carrier.
5. Compare unit received with description of product ordered.
6. Report incomplete shipments to the delivery carrier and your Donaldson representative.
7. Remove crates and shipping straps. Remove loose components and accessory packages before lifting unit from truck.

## Installation Codes and Procedures

1. Safe and efficient operation of the unit depends on proper installation.
2. Authorities with jurisdiction should be consulted before installing to verify local codes and installation procedures. In the absence of such codes, install unit according to the National Electric Code, NFPA No. 70-latest edition.
3. A qualified installation and service agent must complete installation and service of this equipment.

## Installation

### Site Selection

1. The unit can be located on a reinforced concrete foundation or rooftop.
2. Wind, seismic zone, and other live-load conditions must be considered when selecting the location for rooftop-mounted units.
3. Provide clearance from heat sources and interference with utilities when selecting the location for suspended units.

### Unit Location

1. When hazardous conditions or materials are present, consult with local authorities for the proper location of the collector.
2. Foundation or roof support must be sized to accommodate the entire weight of the unit, plus the weight of the collected material, piping, and duct work.
3. Prepare the foundation in the selected location. Install anchor bolts to extend a minimum of 1 3/4-inches above foundation unless otherwise indicated on the Specification Control drawing.
4. Locate the collector to ensure the shortest and straightest inlet- and outlet-duct length, easy access to electrical and compressed-air connections, and routine maintenance.



### Caution!

OSHA may have requirements regarding recirculating filtered air in your facility. Consult with the appropriate local authorities to ensure compliance with all codes regarding recirculating filtered air.

## Electrical Wiring



### Caution!

- Electrical installation must be performed by a qualified electrician and comply with all applicable national and local codes.
- Lock out electrical power sources before performing service or maintenance work.
- Do not install in classified hazardous atmospheres without an enclosure rated for the application.

1. All electrical wiring and connections, including electrical grounding, should be made in accordance with the National Electric Code, NFPA No. 70-latest edition.
2. Check local ordinances for additional requirements that apply.
3. The appropriate wiring schematic and electrical rating must be used. See unit's rating plate for required voltage.
4. If the unit is not furnished with a factory-mounted disconnect, an electric disconnect switch having adequate amp capacity shall be installed in accordance with Part IX, Article 430 of the National Electrical Code, NFPA No. 70-latest edition. Check unit's rating plate for voltage and amperage ratings.
5. Refer to the wiring diagram for the number of wires required for main power wiring and remote wiring.

## Rigging Instructions

### Suggested Tools & Equipment

Crane or Forklift	Pipe Wrenches
Slings, Spreader Bars, and Clevis Pins	Socket Wrenches
Drift Pins	End Wrenches
Clamps	Large Crescent Wrench
Screwdrivers	Drill and Drill Bits
	Pipe Sealant

### Hoisting Information

1. Use all lifting points provided.
2. Use clevis connectors, *not hooks*, on lifting slings.
3. Use spreader bars to prevent damage to units casing.
4. Check the Specification Control drawing for weight and dimensions of the unit, subassemblies, and components to ensure adequate crane capacity.
5. Allow only qualified crane operators to lift the equipment.
6. Refer to applicable OSHA regulations and local codes when using cranes, forklifts, and other lifting equipment.
7. Lift unit and accessories separately, and assemble after unit is in place.
8. Use drift pins to align holes in section flanges during assembly.



### Caution!

- Failure to lift the collector correctly can result in severe personal injury or property damage.
- Use appropriate lifting equipment and adopt all safety precautions needed for moving and handling the equipment.
- A crane or forklift is recommended for unloading, assembly, and installation of the collector.
- Location must be clear of all obstructions, such as utility lines or roof overhang.

## Standard Equipment

Standard installation consists of the base unit, leg, hopper, power pack, electrical, and compressed air connection.

## Hopper Installation

1. Stand the hopper on the discharge end.
2. Apply sealant around the top flange toward the inside-edge of the bolt pattern.
3. Lift the collector and position over the hopper and lower *slowly*.
4. Use drift pins to align holes.
5. Secure collector to hopper using 3/8-16 x 1 1/4-in bolts, flat washers, and nuts. Tighten all hardware securely. See Hopper Installation below.

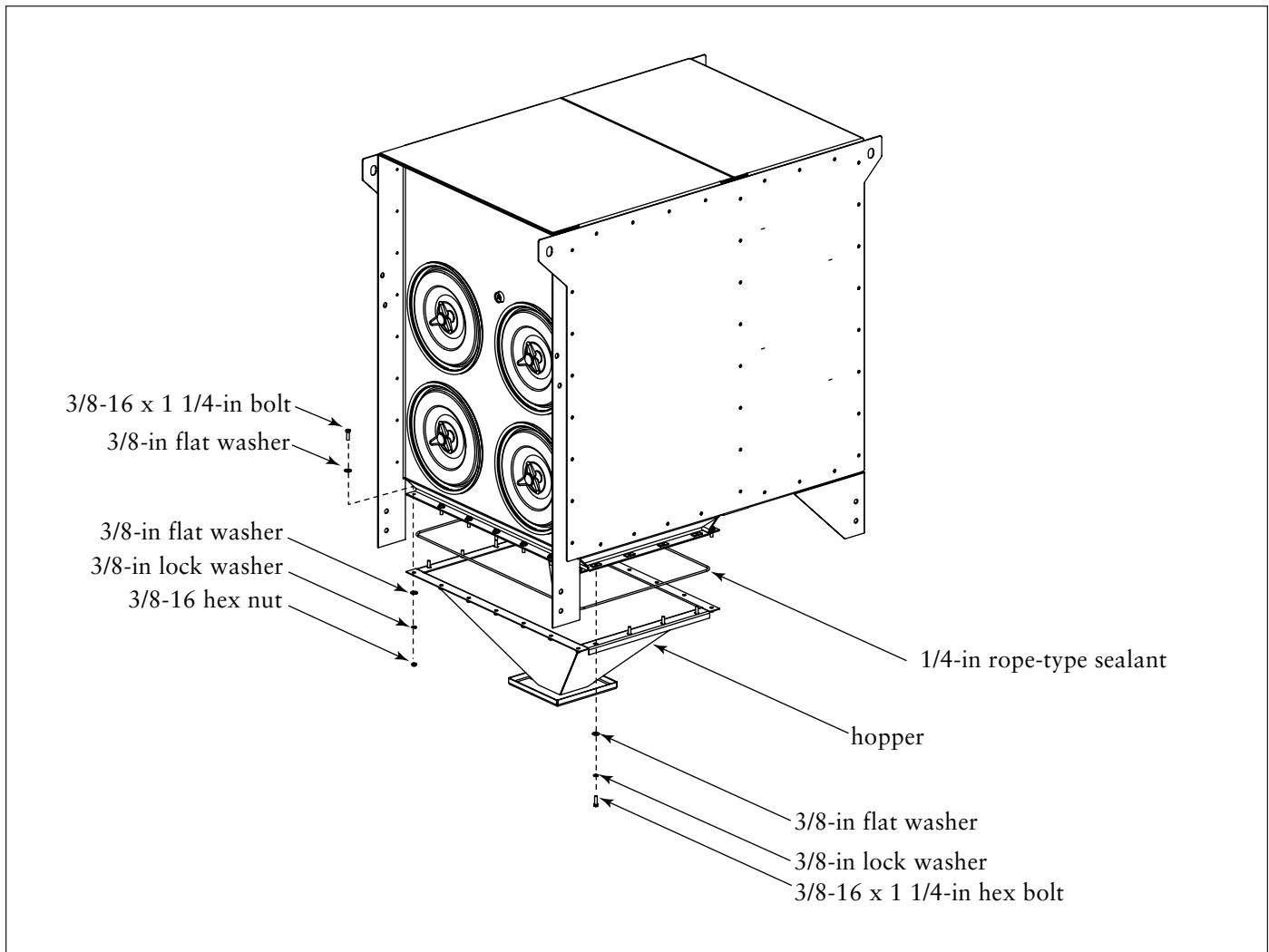

*Hopper Installation*

## Leg Installation

Leg sets are designed for standard height collectors and are rated Seismic Zone 4. Reference the drawing shown below and the leg assembly drawing shipped with the leg set for proper location and assembly.

1. Lift the cabinet and hopper assembly to a suitable height. Attach each leg with 3/4-10 x 1 3/4 or 2 1/2-in bolts, washers, and nuts as shown in Leg and Cross Brace Assembly. **Do not tighten hardware at this time.**
2. Recheck the position of the leg sets and cross braces.
3. Using a crane, lift the assembled unit onto the anchor bolts. Fasten each leg pad to the anchor bolts using flat washers, lock washers, and hex nuts provided by others. **Do not tighten hardware at this time.**
4. Level unit. Tighten all hardware on legs, cross braces, and foundation anchors.
5. Remove crane.

**Note:** Tighten all hardware before removing crane.

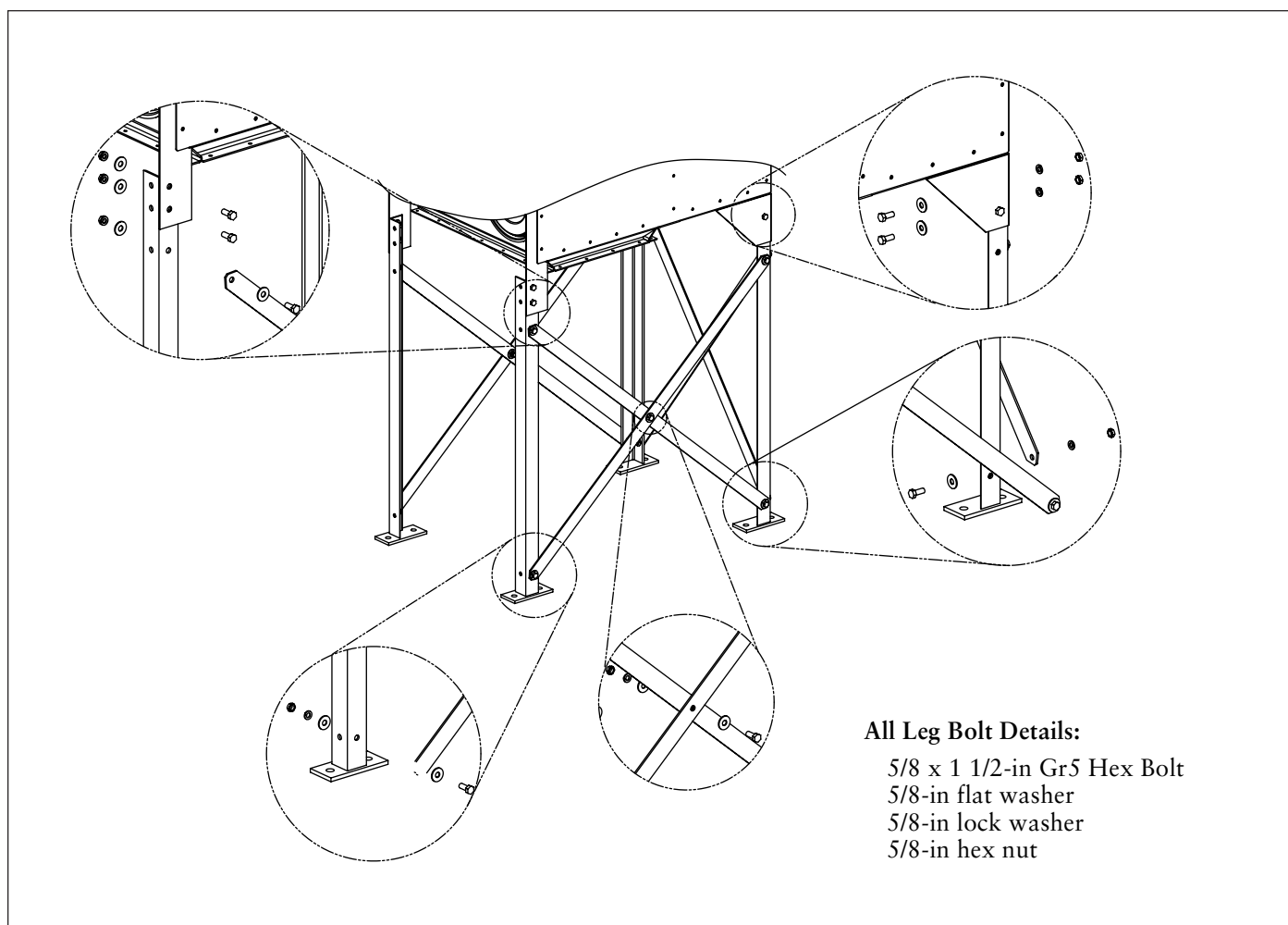

*Leg and Cross Brace Assembly*

## Power Pack Installation

Two types of power packs are available for the Downflo II: Torit Backward Incline, TBI, and Torit Radial Blade, TRB. Both power packs are designed to fit on the top or side of the Downflo II.

### TBI

1. The power packs are shipped assembled and partial disassembly is required before installing.
2. Remove eight motor-mount bracket fasteners and remove the motor, motor-mount bracket, and blower wheel as an assembly as shown.
3. Turn housing over and apply sealant to the outside-edge of the bolt pattern on the blower housing. Mount the blower housing to the collector using the inlet cone fasteners.

**Notes:** For all top-mounted TBI with and without a blast-gate style damper, and top-mounted TRB with a blast-gate style damper, install a spacer ring between the blower housing and the collector to provide the necessary clearance for the damper installation.

For top-mount TBI with explosion vent, install the spacer spool between the blower housing and the collector to provide the necessary clearance for explosion vent and weather dome. Position of the blower fan housing should not restrict explosion vent opening.

4. Apply sealant to the outside-edge of the bolt pattern on the blower housing. Reinstall the motor, bracket, and blower wheel assembly.
5. Rotate blower wheel after installation to ensure proper clearance between the inlet cone and the blower wheel.

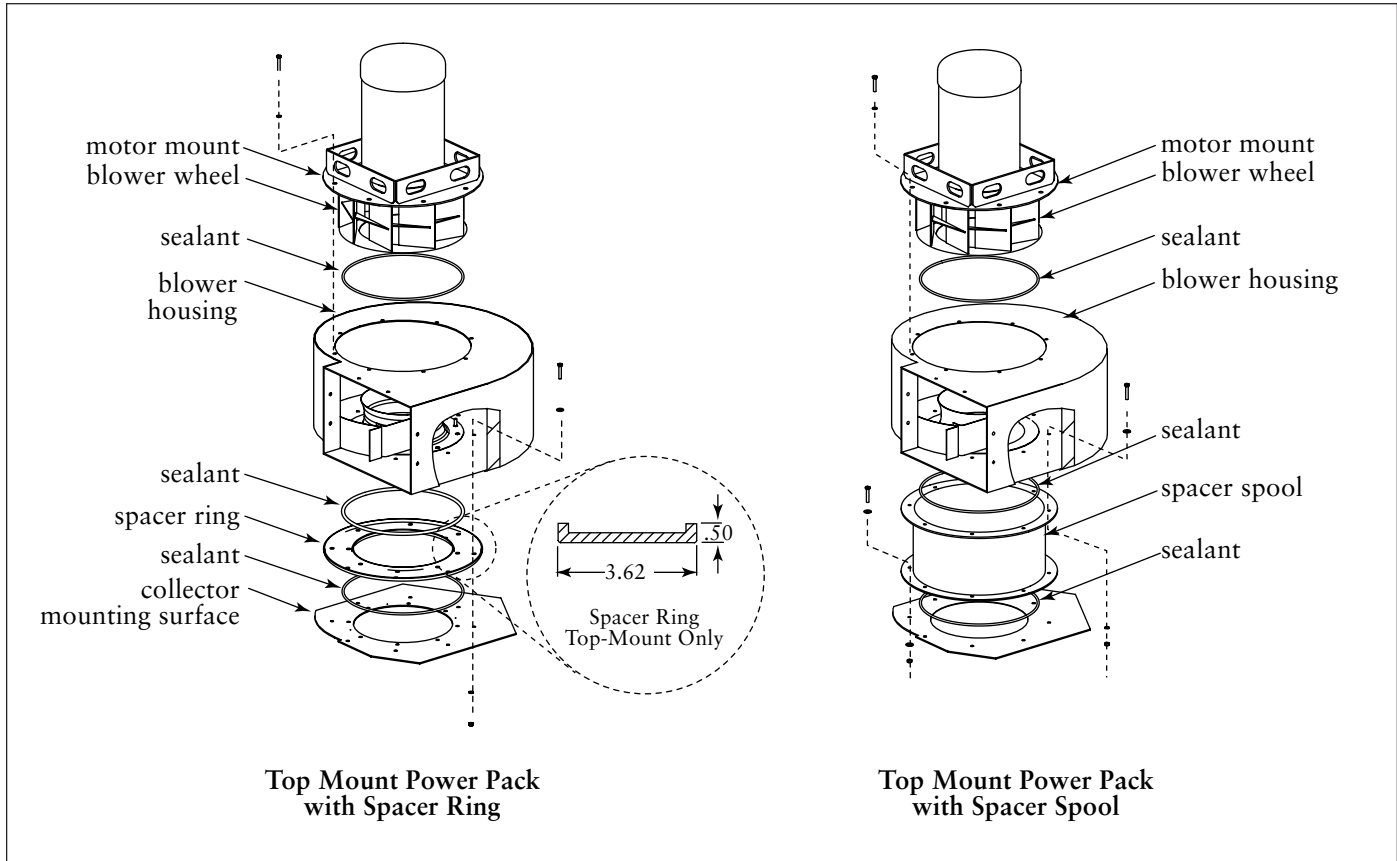

*Power Pack, TBI with Spacer Ring and TBI with Spacer Spool for Explosion Vented Units*

**TRB**

1. The power packs are shipped assembled and partial disassembly is required before installing.
2. Disassemble the power pack by removing the blower housing fasteners and splitting the blower halves. The motor half contains the motor, half of the blower housing, and the blower wheel.
3. Apply sealant to the collector toward the inside-edge of the bolt pattern.

**Note:** For all top-mounted TBI with and without a blast-gate style damper, and top-mounted TRB with a blast-gate style damper, install a spacer ring between the blower housing and the collector to provide the necessary clearance for the damper installation.

4. Mount the inlet half of the blower housing to the collector using the hardware supplied.
5. Reassemble the motor half of the blower housing the inlet half.
6. Rotate blower wheel after installation to ensure proper clearance between the inlet cone and the blower wheel.

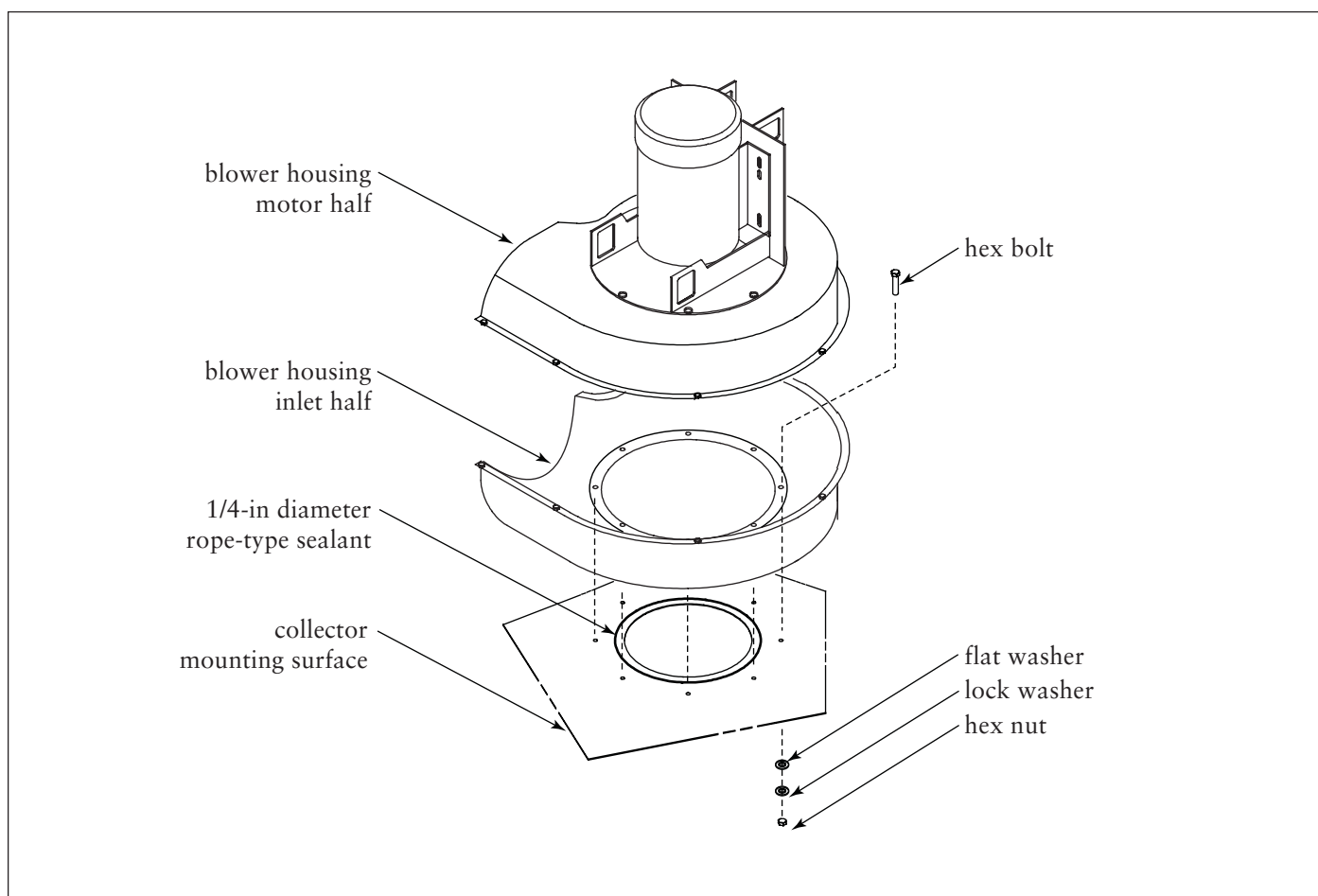

*Power Pack Installation, TRB*

## Electrical Connection

### Solid-State Timer Installation



#### Caution!

- Electrical installation must be performed by a qualified electrician and comply with all applicable national and local codes.
- Lock out electrical power sources before performing service or maintenance work.
- Do not install in classified hazardous atmospheres without an enclosure rated for the application.

**Note:** The solid-state timer requires a 105 to 135-Volt, customer-supplied power supply.

1. Mount a customer-supplied motor starter with a low-voltage control circuit in a convenient location.
2. Mount the solid-state timer as close to the blower as possible.

**Note:** Do not mount the solid-state timer on the unit. Mechanical vibration can damage the control.

3. Using the wiring diagram supplied, wire the blower motor, blower-motor starter, solid-state timer, and solenoid valves. Use appropriate wire gauge for rated amp load as specified by local codes.

4. Turn the blower motor ON then OFF to check for proper rotation by referencing the rotation arrow located on the motor's mounting plate.



#### Caution!

- *Do not* look into fan outlet to determine rotation.
- Check that the exhaust plenum is free of tools or debris before checking blower/fan rotation.
- Stand clear of exhaust to avoid personal injury.

#### To reverse rotation, three-phase power supply:

Turn electrical power OFF at source and switch any two leads on the output-side of the fan-motor starter.

5. With power supply ON, check the operation of the solenoid valves. The valves should open and close sequentially at factory set 10-second intervals.
6. If a Photohelic gauge or similar device is used to control the solid-state timer and the jumper on the pressure switch portion of the timer is removed, the solenoid valves pulse only when the differential pressure reaches the high-pressure setpoint. The valves continue to pulse until the low-pressure setpoint is reached.

**Solenoid Connection**

The unit is equipped with 115-V solenoid valves that control the pulse-cleaning valves, which clean the filters.

One of three types of solenoid enclosures, the weatherproof NEMA 4 with 3D2 solenoids, the explosion proof NEMA 7 with 5D2 solenoids, or the explosion proof NEMA 9 with 5D2 solenoids, are mounted near or on the unit's compressed-air manifold.

Wire the solenoids to the solid-state timer following the wiring diagram supplied with the unit. Filter life and cleaning operation will be affected if not wired correctly.

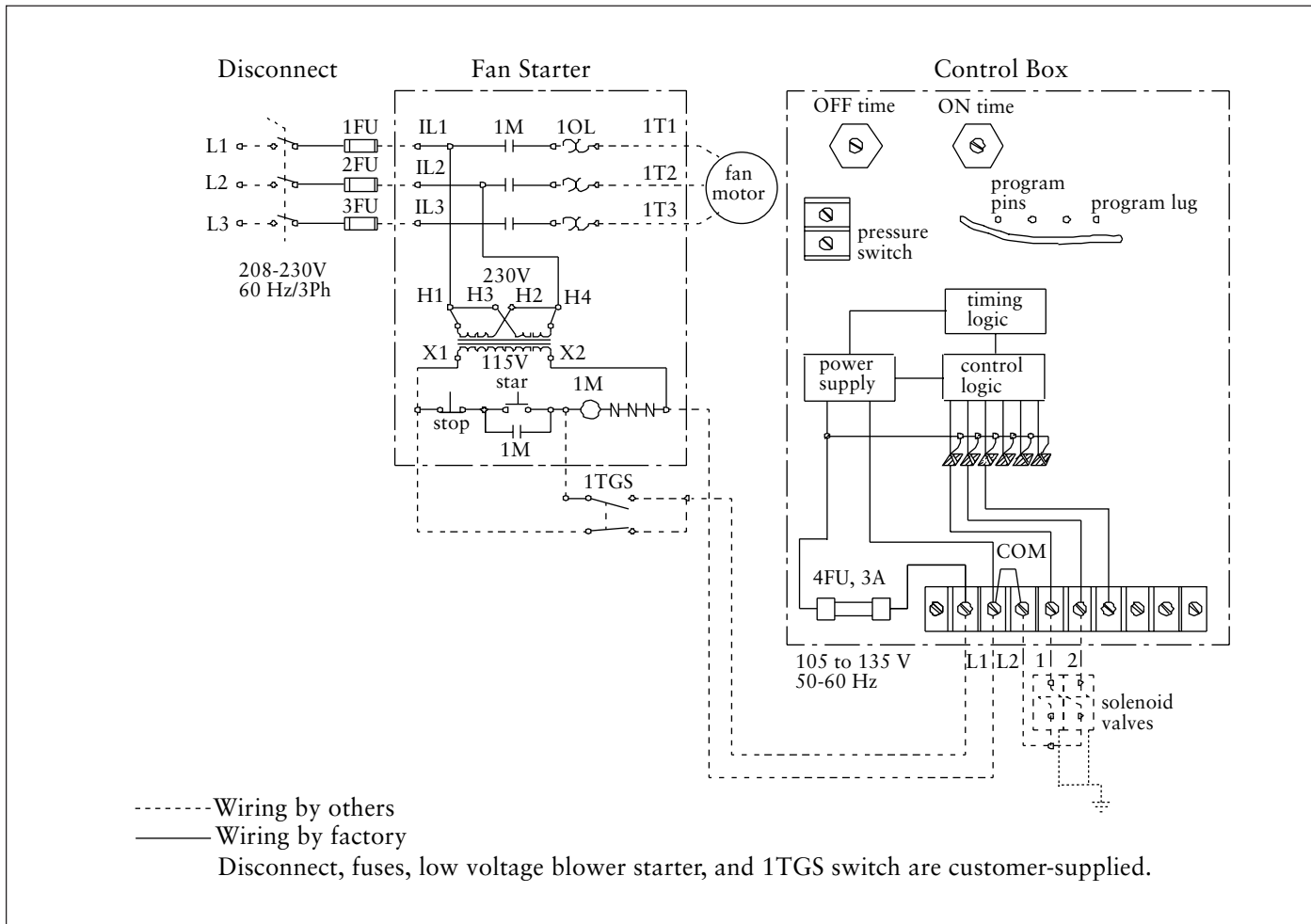

*Solid-State Timer Wiring*

### **Timer and Solenoid Specifications**

Power to the solid-state timer is supplied to Terminals L1 and L2, which operate in parallel with the blower starter's low-voltage coil. On blower start-up, power is supplied to the timer and the preset OFF time is initiated. At the end of the OFF time, the timer energizes the corresponding solenoid valve to provide the ON time cleaning pulse for one diaphragm valve and then steps to the next until all filters have been cleaned.

To pulse when the blower is OFF, install a toggle switch as shown on the Solid-State Timer Wiring Diagram. When the toggle switch is ON, the timer receives power and energizes the solenoid valve pulse-cleaning operation even though the blower is turned OFF.

#### **Input**

105-135V/50-60Hz/1Ph

#### **Output Solenoids**

The load is carried and turned ON and OFF by the 200 watt maximum-load-per-output solid-state switch.

#### **Pulse ON Time**

Factory set at 100-milliseconds, or 1/10-second.

**Note:** *Do not* adjust pulse ON time unless the proper test equipment is available. Too much or too little ON time can cause shortened filter life.

#### **Pulse OFF Time**

Factory set at 10-seconds, adjustable from 1 to 1.5-second minimum to maximum 60 to 66-second.

#### **Operating Temperature Range**

-20° F to 130° F

#### **Transient Voltage Protection**

50 kW transient volts for 20-millisecond duration once every 20 seconds, 1% duty cycle.

#### **Solenoid Valves**

115-V at 19.7 watts each

#### **Compressed-Air**

Set compressed-air supply at 90-psig. The timer is factory set to clean one filter or set of filters every 10-seconds.

**Note:** *Do not* set compressed-air pressure above 100-psig. Component damage will occur.

### Checker™ board Control Panel

The Checker board provides cleaning control, diagnostic review of the operational parameters, diagnostic review of the system components, and a record of operational data and fault conditions for future review. The operator interface provides control of unit functions and operational status information.

The design allows a host computer to remotely control the unit, accept change to operational parameters, and check operational status.

1. Mount the control enclosure in a convenient, accessible location that provides the best visual advantage. Mount the enclosure to a wall or column with little or no vibration and away from static discharges that could damage components.
2. Make the proper electrical and pneumatic connections to the collector and motor starter following the diagrams and instructions supplied with the Checker board.
3. Verify proper blower rotation by pushing the start-stop button ON then OFF. Rotation must match the rotation arrow on the blower housing as viewed from the top.
4. Calibrate the Checker board computer to the system airflow. Establish filter cleaning settings and service intervals.

**Note:** See the Checker board Installation and Operation Manual, IOM 7220601 for complete installation and operating instructions.

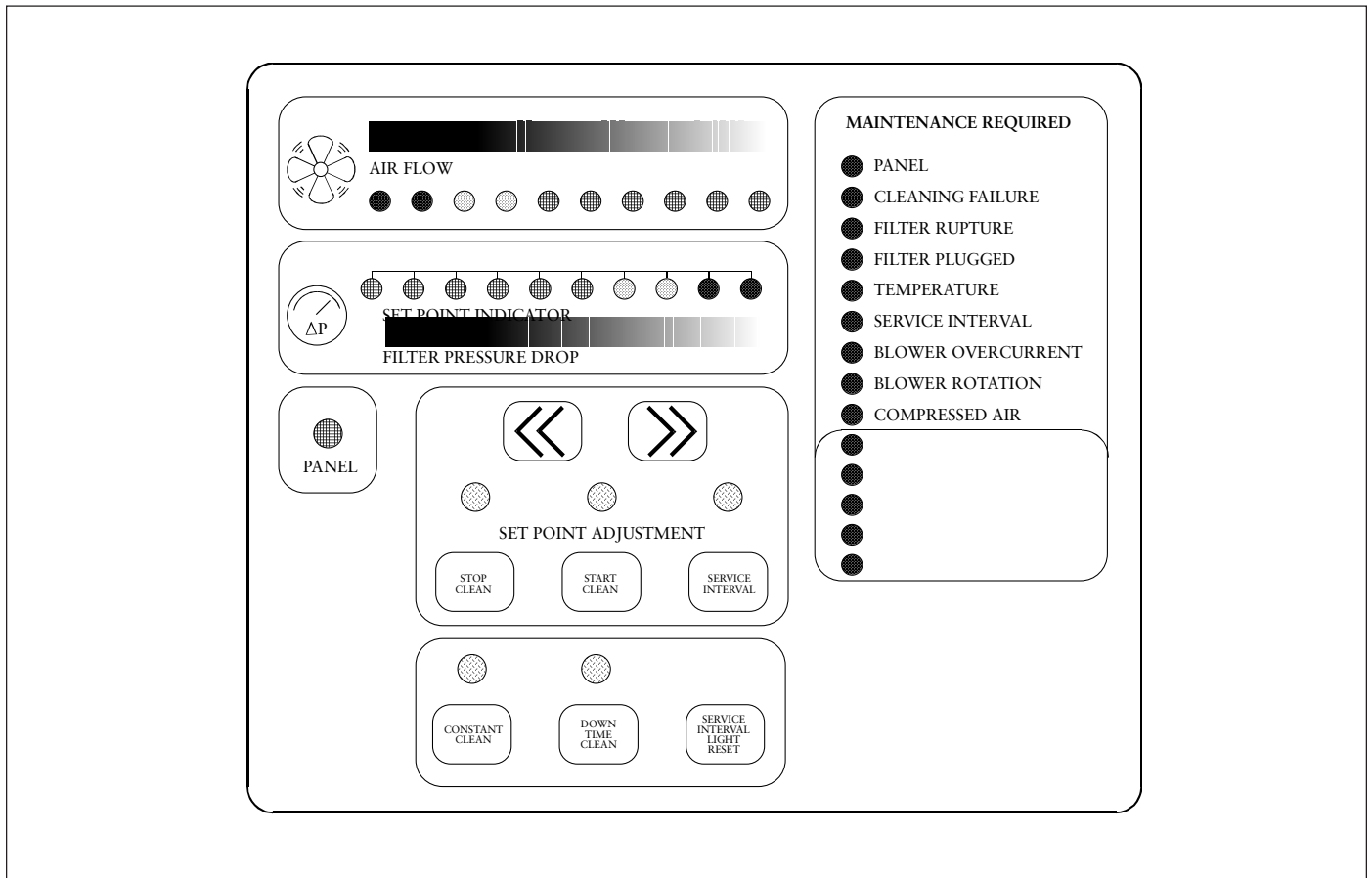

Checker board Control Panel

### ***Solenoid Connection***

One of three types of solenoid enclosures, the weatherproof NEMA 4 with 1/8-in solenoid valves; the gas-explosion proof NEMA 7 with 1/8-in solenoid valves; or the dust-explosion proof NEMA 9 with 1/8-in solenoid valves, is mounted near or on the unit's compressed-air manifold.

### ***Control Specifications***

#### **Input**

Low Range: 90-130V/50-60Hz/1Ph

High Range: 180-260V/50-60Hz/1Ph

#### **Output Relay Voltage and Contact Rating:**

The output relays are independent of the input voltage. Relays can accept power from any voltage source desired.

VDE: 8 amp, 250-Volt AC

UL: 10 amp, 240-Volt AC

CSA: 8 amp, 24-Volt DC

**Pulse ON Time**

Factory set at 100-milliseconds, or 1/10-second.

Note: *Do not* adjust pulse ON time unless the proper test equipment is available. Too much or too little ON time can cause shortened filter life.

**Pulse OFF Time**

Factory set at 10-seconds. The pulse OFF time can only be adjusted by modifying the parameters contained in the microprocessor software. Contact your representative for assistance.

**Operating Temperature Range**

Ambient 0° F to 140° F.

**Relays**

There are twenty-four relay positions, twenty-three on 24-Volt DC systems that can be used to control solenoid valves or other filter cleaning devices.

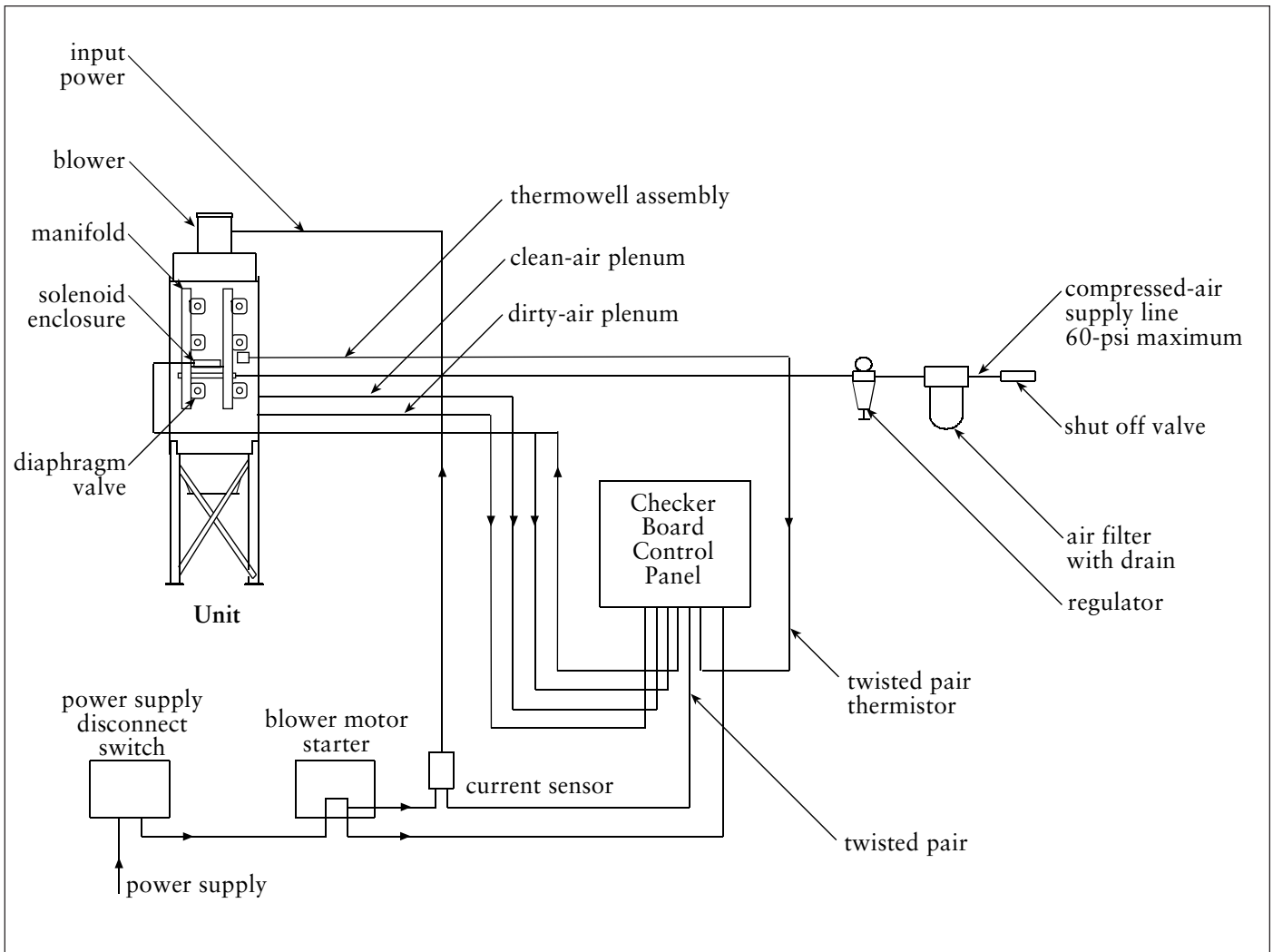

Checker board Wiring

## Compressed Air Installation



### Caution!

- The compressed-air supply must be oil and moisture free. Contamination in the compressed air used to clean filters will result in poor cleaning, cleaning valve failure or poor collector performance.
- Purge compressed-air lines to remove debris before connecting to the unit's compressed-air manifold.
- Turn compressed-air supply OFF and bleed lines before performing service or maintenance work.

1. Remove the plastic pipe plug from the unit's air manifold and connect the compressed-air supply line. Use thread-sealing tape or pipe sealant on all compressed-air connections.
2. Install a customer-supplied shut-off valve, bleed-type regulator with gauge, filter, and automatic condensate valve in the compressed-air supply line.

**Note:** All compressed-air components must be sized to meet the maximum system requirements of 90-psi supply pressure.

*Do not* increase supply pressure above 100-psi. Component damage can result.

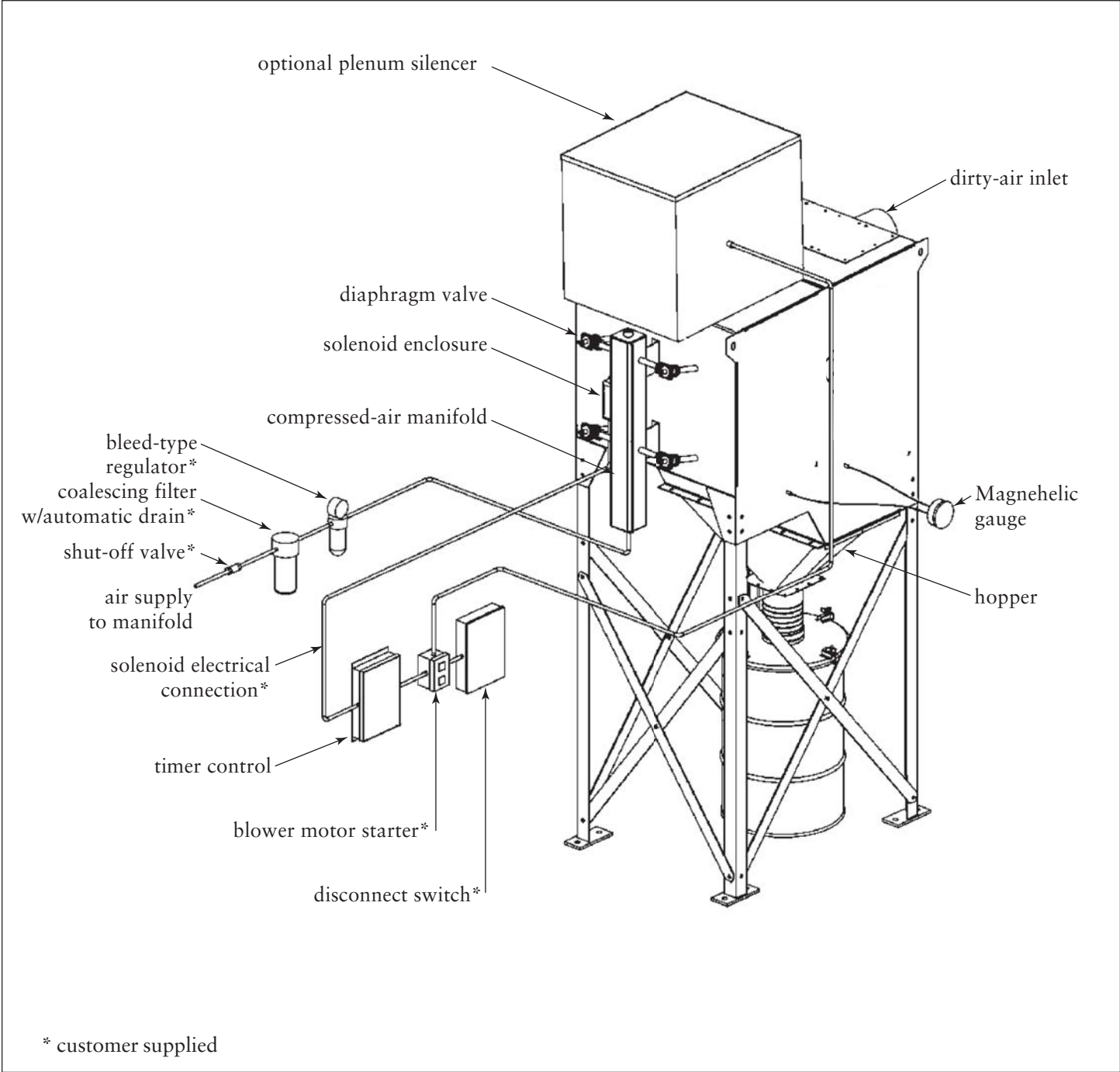

Compressed Air Installation

## Preliminary Start-Up Check

1. Check all electrical connections for tightness and contact.
2. Check for and remove all loose items in or near the inlet and outlet of the unit.
3. Check that all remote controls are wired into the control system, and all service switches are in the OFF position.
4. Check that all optional accessories are installed properly and secured.
5. Check that hopper discharge is open and the storage container is sealed, if equipped. Excess airflow to the blower will cause electrical failure.
6. Turn power ON at source.
7. Turn the compressed-air supply ON. Adjust pressure regulator for 90 to 100-psig.
8. Turn the fan motor ON then OFF to check for proper rotation by referencing the rotation arrow located on the motor's mounting plate.

### To reverse rotation, three-phase power supply:

Turn electrical power OFF at source and switch any two leads on the output-side of the fan-motor starter.

9. Adjust the blower for proper airflow by adjusting the volume control damper on the blower/fan discharge, if equipped.

**Note:** Excess airflow can shorten filter life, cause electrical system failure, and blower motor failure.



### Caution!

- *Do not* look into fan outlet to determine rotation.
- Check that the exhaust plenum is free of tools or debris before checking blower/fan rotation.
- Stand clear of exhaust to avoid personal injury.

### Optional Equipment

#### 5-Gallon Pail Pack

- 1. Apply sealant to the hopper flange or the pail cover mounting plate flange toward the inside edge of the bolt pattern.
- 2. Fasten the pail pack to the hopper using the bolts, washers, and nuts supplied.

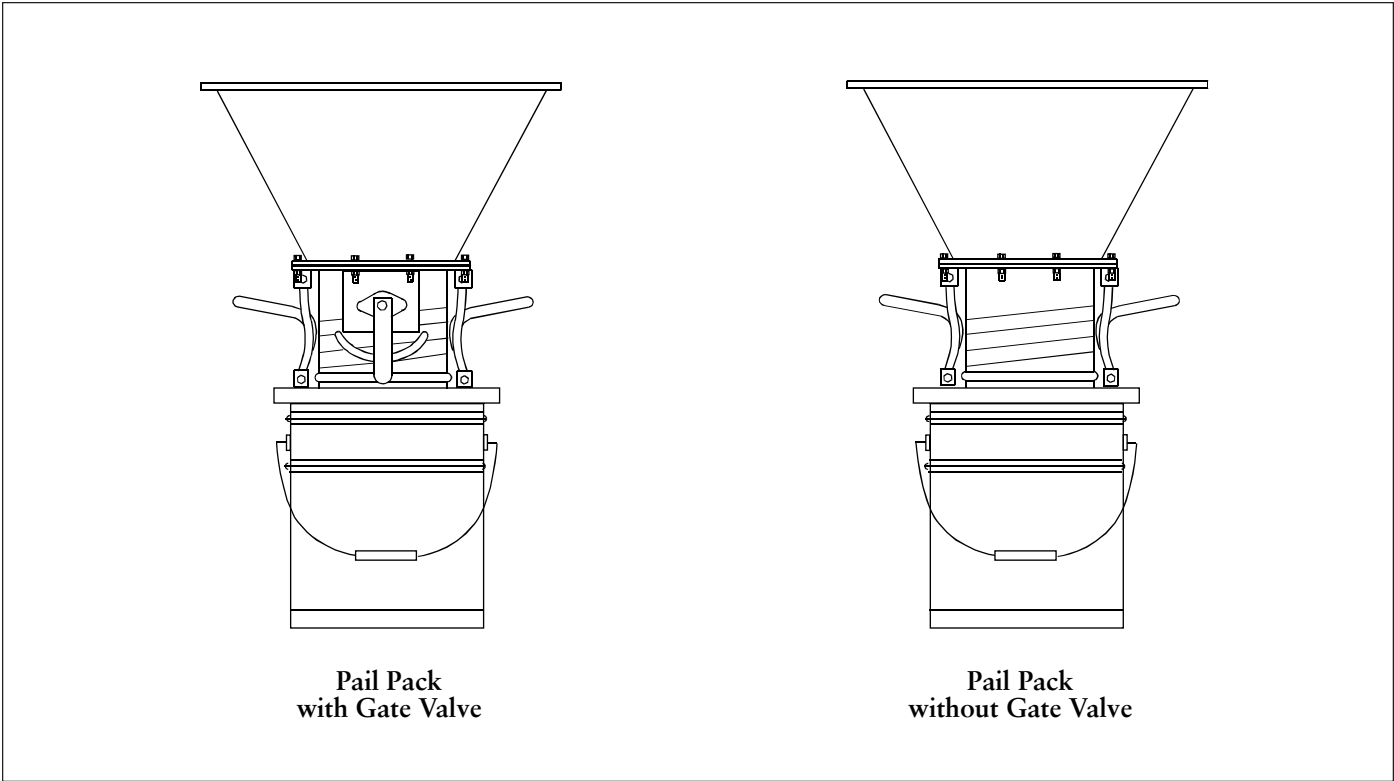

*5-Gallon Pail Pack with and without Gate Valve*

## 55-Gallon Drum Pack

The drum pack is designed to fit a customer-supplied, standard 55-gallon drum and provides easy access for dust removal and disposal. A flexible hose connects the drum cover and slide gate, or drum cover and adapter.

### **With Slide Gate**

1. Place a 1/8-in gasket spacer between the hopper flange and slide gate as shown.
2. Attach the drum pack and slide gate to the hopper flange using 3/8-16 bolts, washers, and hex nuts.

3. Attach the drum cover to the 55-gallon drum.
4. Use latches to secure the cover to the drum, if equipped.
5. Connect the flexible hose between the drum cover and slide gate. Secure with hose clamps.

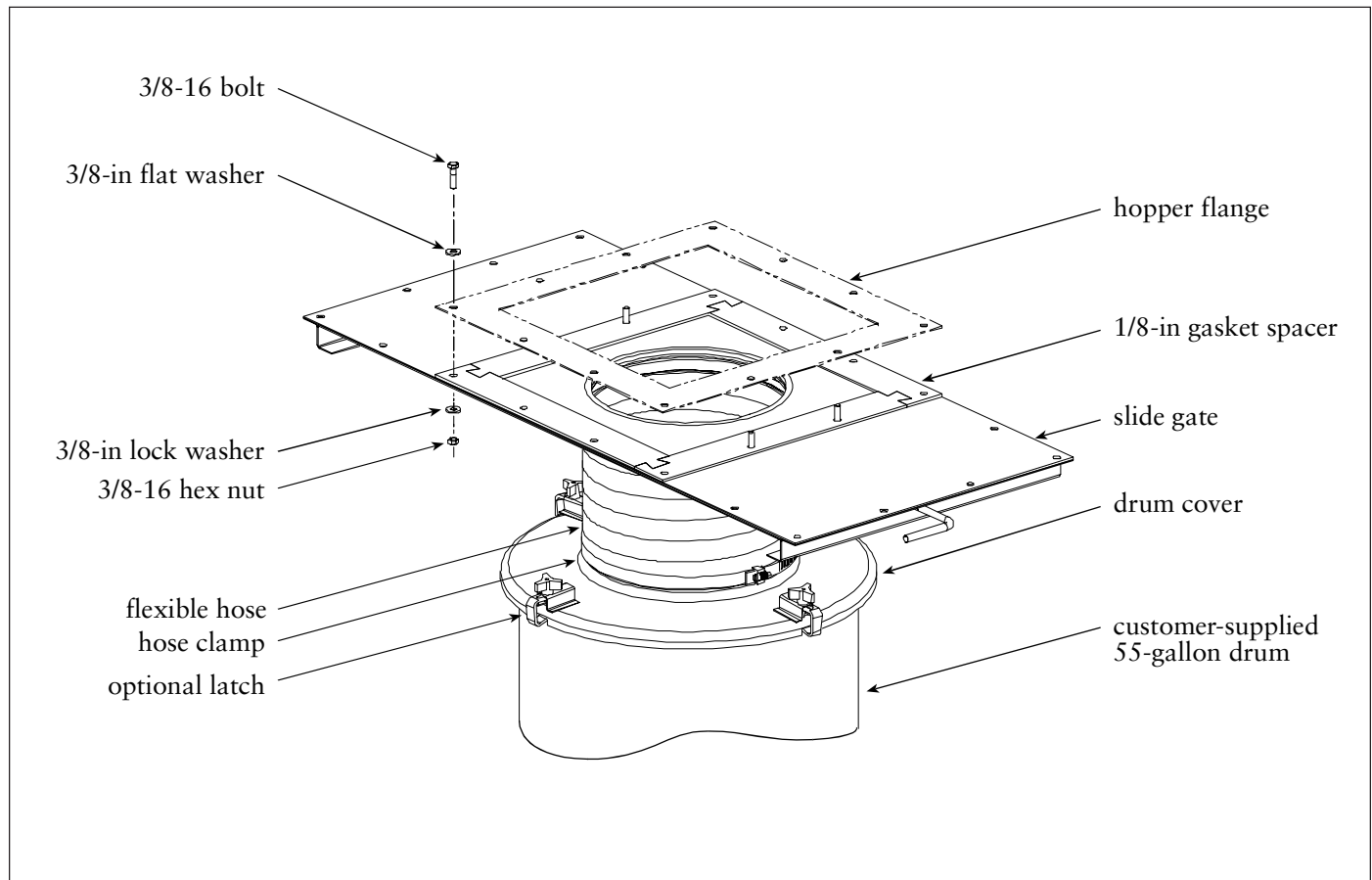

*55-Gallon Drum Pack with Slide Gate*

**Without Slide Gate**

1. Place a 1/4-in diameter, rope-type sealant between the hopper flange and the adapter as shown.
2. Attach the adapter to the hopper flange using 3/8-16 bolts, washers, and hex nuts.
3. Attach the drum cover to the 55-gallon drum.
4. Use latches to secure the cover to the drum, if equipped.
5. Connect the flexible hose between the drum cover and the adapter. Secure with hose clamps.

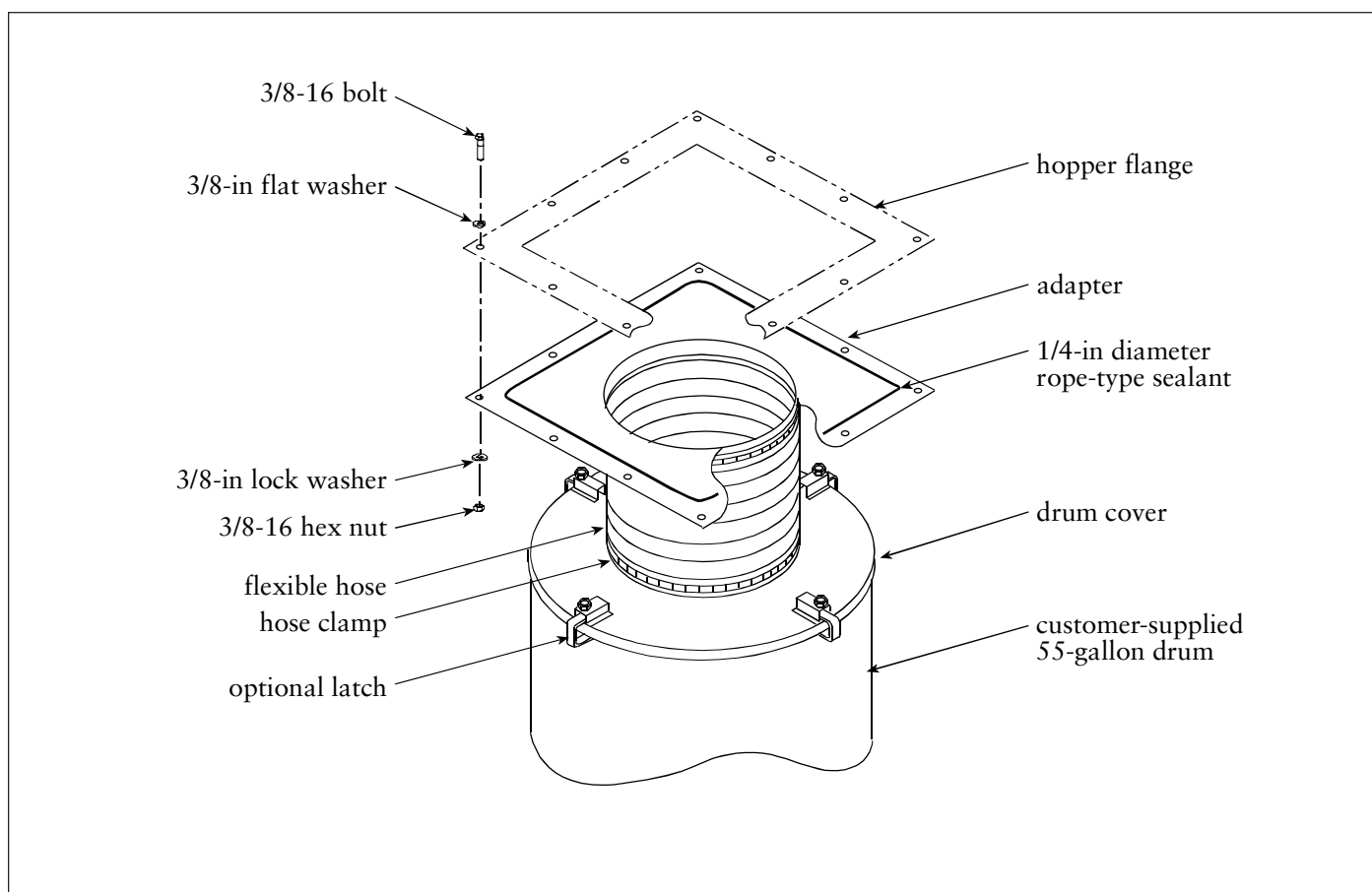

*55-Gallon Drum Pack without Slide Gate*

## Magnehelic Gauge

The Magnehelic is a differential pressure gauge used to measure the pressure difference between the clean- and dirty-air plenums and provides a visual display of filter change requirements. The high-pressure tap is located in the dirty-air plenum and the low-pressure tap is located in the clean-air plenum.

1. Choose a convenient, accessible location on or near the unit for mounting that provides the best visual advantage.

If unit is equipped with factory-installed pressure taps, skip to Step 5.

2. Before drilling, place a piece of non-combustible cloth over the filter opening in the clean-air plenum to protect them from drilling chips.
3. Place a piece of wood behind the drill location in the dirty-air plenum to protect the filters from damage by the drill bit.
4. Mount the pressure tap hardware on the clean-air plenum panel. Mount the pressure tap with the tee inside the dirty-air plenum.
5. Plug the pressure ports on the back of the gauge using two 1/8-in NPT pipe plugs supplied. Install two 1/8-in NPT male adapters supplied with the gauge into the high- and low-pressure ports on the side of the gauge. Attach the mounting bracket using three #6-32 x 1/4-in screws supplied.
6. Mount the gauge and bracket assembly to the supporting structure using two, self-drilling screws.
7. Thirty-five feet of plastic tubing is supplied and must be cut in two sections. Connect one section of tubing from the gauge's high-pressure port to the pressure fitting located in the dirty-air plenum. Connect remaining tubing from the gauge's low-pressure port to the fitting in the clean-air plenum. Additional tubing can be ordered from your representative.
8. Carefully remove the cloth protecting the filters. Close access doors and tighten securely by hand.
9. Zero and maintain the gauge as directed in the manufacturer's Operating and Maintenance Instructions provided.

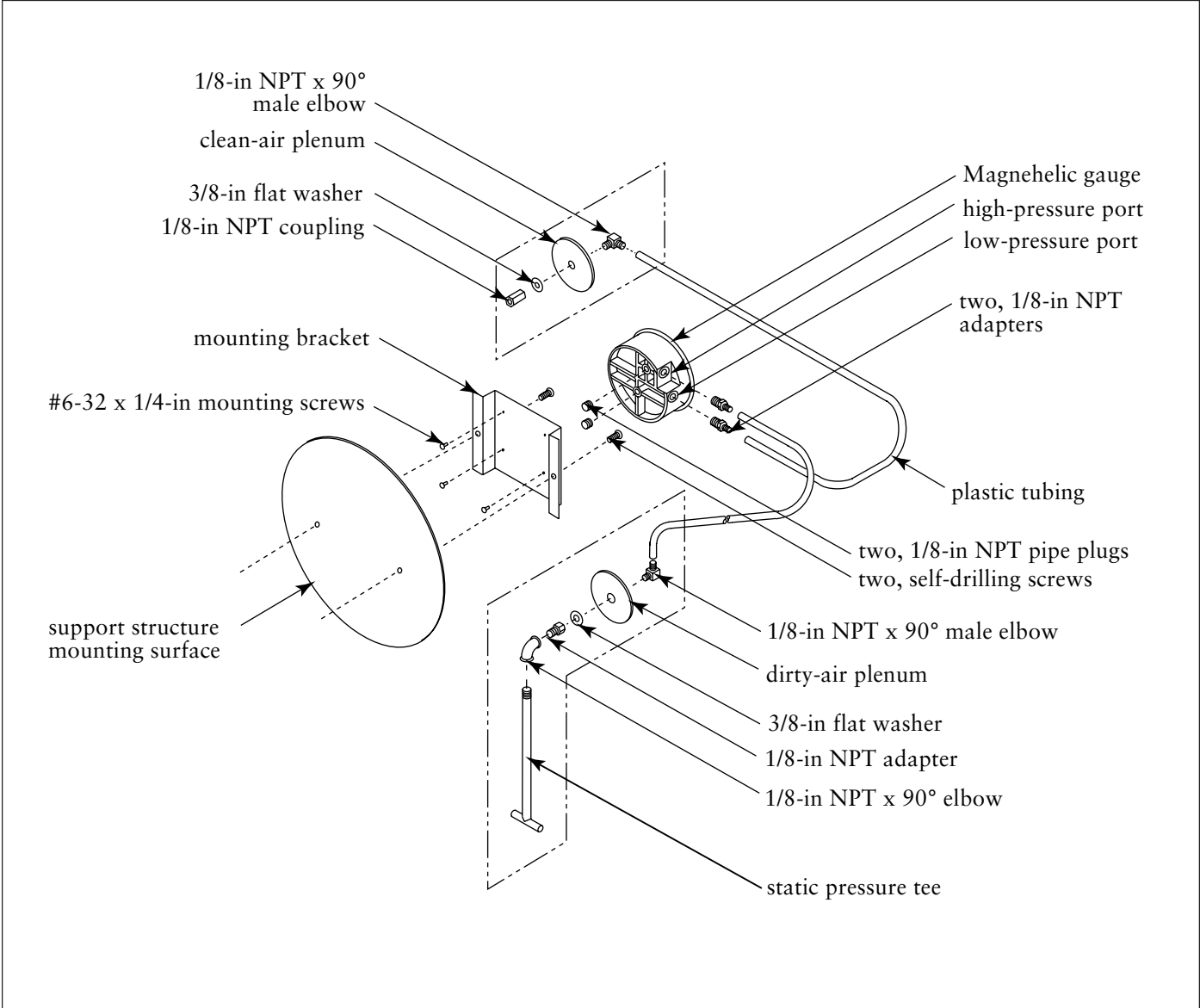

*Magnehelic Gauge Assembly*

## Photohelic Gauge

The Photohelic combines the functions of a differential pressure gauge and a pressure-based switch. The gauge function measures the pressure difference between the clean- and dirty-air plenums and provides a visual display of filter condition. The high-pressure tap is located in the dirty-air plenum and a low-pressure tap is located in the clean-air plenum. The pressure-based switch function provides high-pressure ON and low-pressure OFF control of the filter cleaning system.



### Caution

- Electrical installation must be performed by a qualified electrician and comply with all applicable national and local codes.
- Turn power OFF during installation or maintenance.
- Do not install in classified hazardous atmospheres without an enclosure rated for the application.

1. Choose a convenient, accessible location on or near the unit for mounting that provides the best visual advantage.
2. Mount the gauge to the remote panel or door using the mounting ring, retaining ring, and four #6-32 x 1 1/4" screws. Do not tighten screws. Connect two, 1/8" NPT x 1/4" OD male adapters to the gauge's high- and low-pressure ports. Align the adapters to the 2.375-in hole in the right-hand side of the mounting bracket. Tighten screws.
3. On the back of the gauge, remove four #6-32 x 5/16" screws and plastic enclosure. Set aside. Add two jumper wires supplied by customer. Remove the jumper from the pressure switch located on the timer board, if equipped. Using the 3/4-in conduit opening, wire the gauge as shown. Reassemble and fasten the enclosure securely.

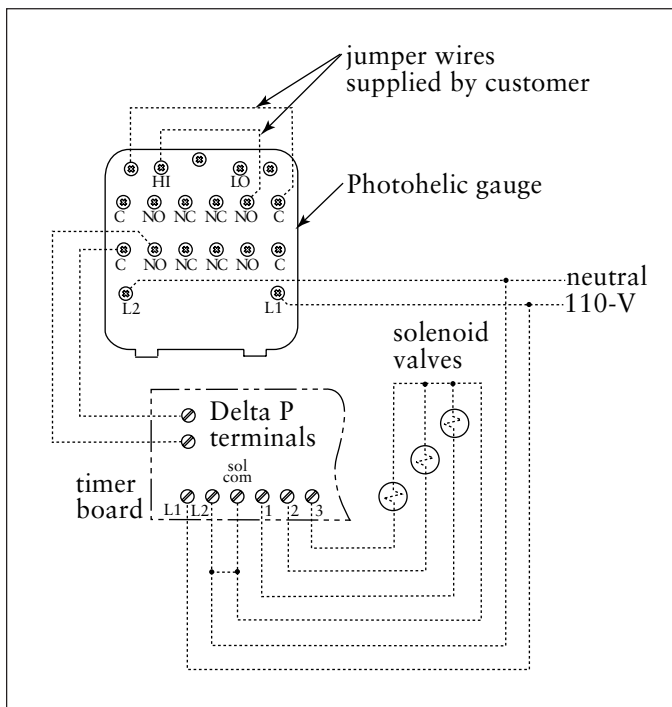

*Photohelic Gauge Wiring*

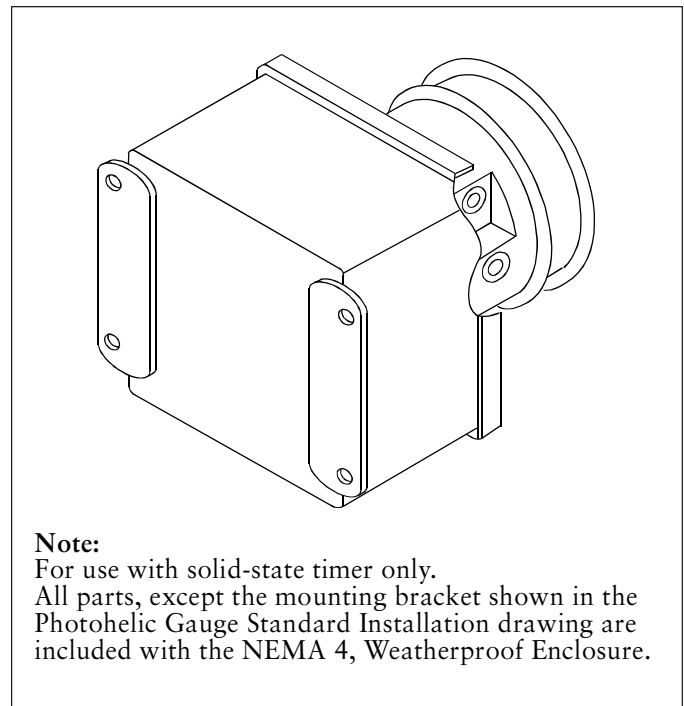

### Note:

For use with solid-state timer only. All parts, except the mounting bracket shown in the Photohelic Gauge Standard Installation drawing are included with the NEMA 4, Weatherproof Enclosure.

*Photohelic Gauge in NEMA 4 Enclosure*

4. Thirty-five feet of plastic tubing is supplied and must be cut in two sections. Connect one section of tubing from the gauge's high-pressure port to the pressure fitting located in the dirty-air plenum. Connect remaining tubing from the gauge's low-pressure port to the fitting in the clean-air plenum. Additional tubing can be ordered from your representative.
5. Zero and maintain the gauge as directed in the manufacturer's Operating and Maintenance Instructions provided.
6. To install the Photohelic Gauge mounted in a NEMA 4 Weatherproof Enclosure, follow Steps 4 and 5.

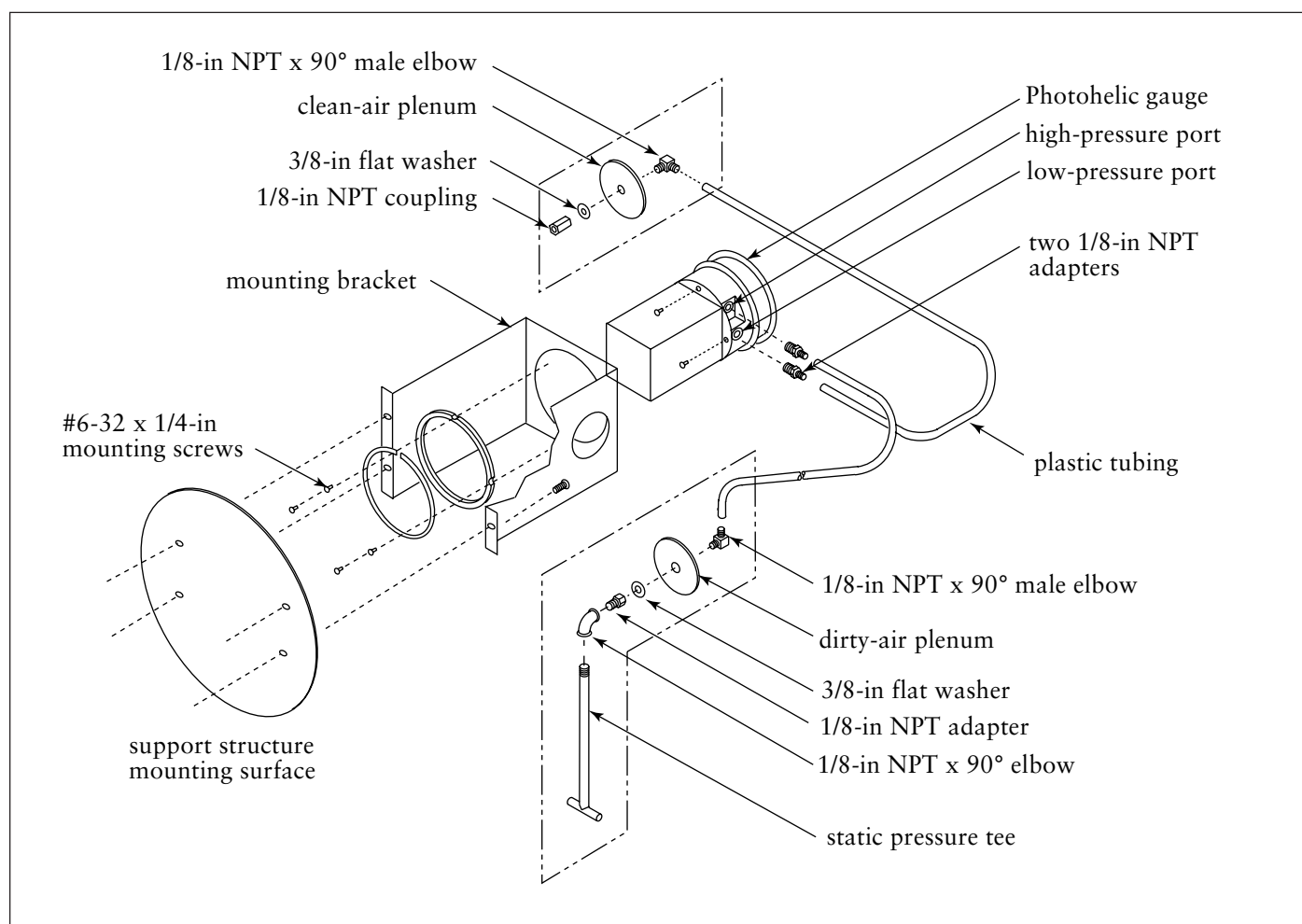

*Photohelic Gauge Installation*

## Delta P Control

When combined with a pulse timer, the Delta P control monitors the differential pressure between the clean- and dirty-air plenums, providing a visual display of the filter condition. Set the high-pressure ON and low-pressure OFF setpoints to control the filter cleaning system.

**Note:** The Delta P control is factory set for 115-V. To operate at 230-V, the jumper settings on the printed circuit board must be changed. See Optional Settings on Page 30.



### Caution!

- Electrical installation must be performed by a qualified electrician and comply with all applicable national and local codes.
- Turn power OFF during installation or maintenance.
- Do not install in classified hazardous atmospheres without an enclosure rated for the application.

1. Choose a location near the unit that permits access to the keypad for adjustments and observation of the pressure drop. If possible, mount the control indoors.
2. Mount the control enclosure using four self-drilling, self-tapping screws.

**Note:** Use vibration isolators in high vibration areas.

3. Install conduit between the control's enclosure, the solid-state timer, and the solenoid valve enclosure on the collector.
4. Using the wiring diagram provided with the control, make the wiring connections to the Delta P control, the solid-state timer, and the solenoid valves. Make the required connections to the motor starter's low-voltage terminals.

**Note:** Use proper grounding and handling procedures to prevent permanent damage to this device. Handle the printed circuit board by the edges *only*. **Do not** touch the socketed E<sup>2</sup>PROM pins.

5. Wire the auxiliary alarm circuit, if desired. This relay activates the ALARM light on the control panel if the pressure drop reaches the alarm

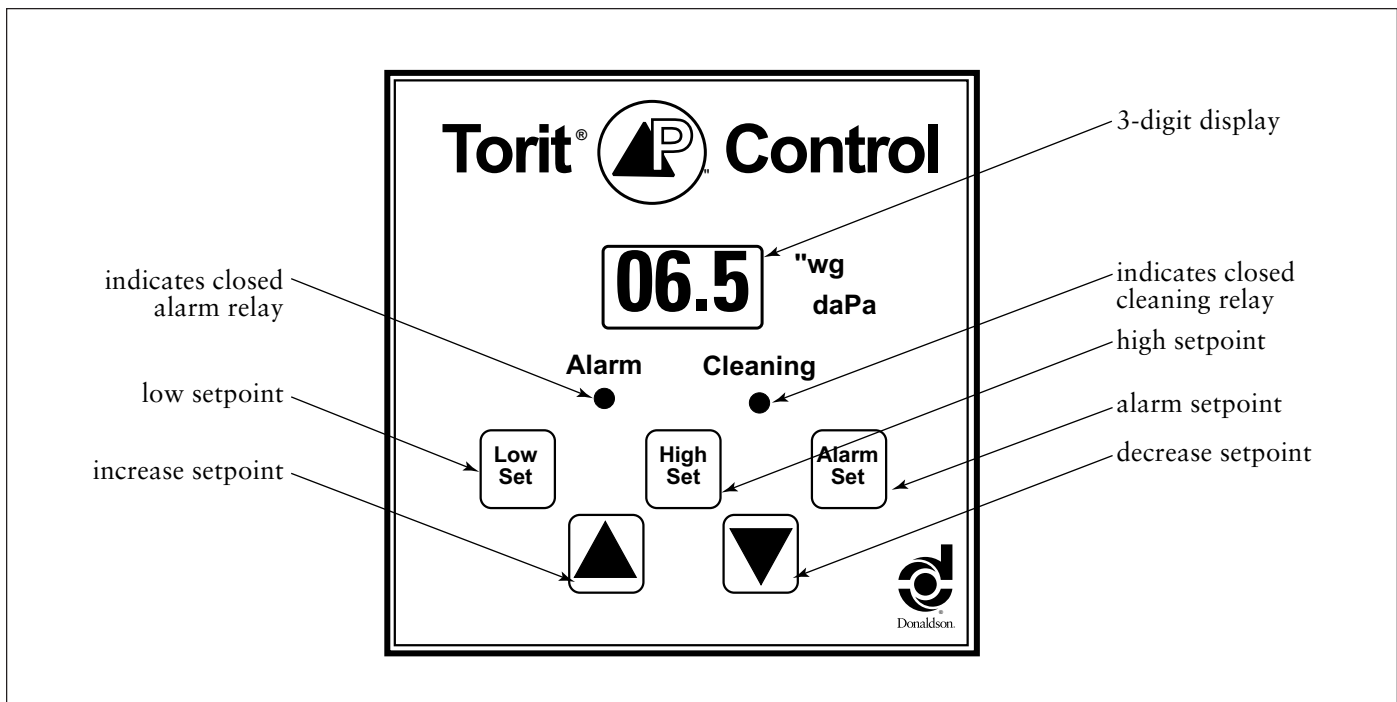

*Delta P Control Display Panel*

setpoint. The auxiliary relay can also be used to activate visual or audible alarms provided by others.

- Thirty-five feet of plastic tubing is supplied with the control and must be cut in two sections. Connect one section of tubing from the control enclosure's high-pressure port to the pressure tap on the dirty-air plenum. Connect the remaining section of tubing from the control enclosure's low-pressure port to the pressure

tap on the clean-air plenum. Additional tubing can be ordered from your representative.

- Place the program wire on the solid-state timer board pin to match the number of solenoid-valve connections used.
- Apply power to the control. Set the high- and low-pressure setpoints to start and stop the cleaning process. Set the alarm setpoint to activate the alarm display. See Control Calibration section on page 30.

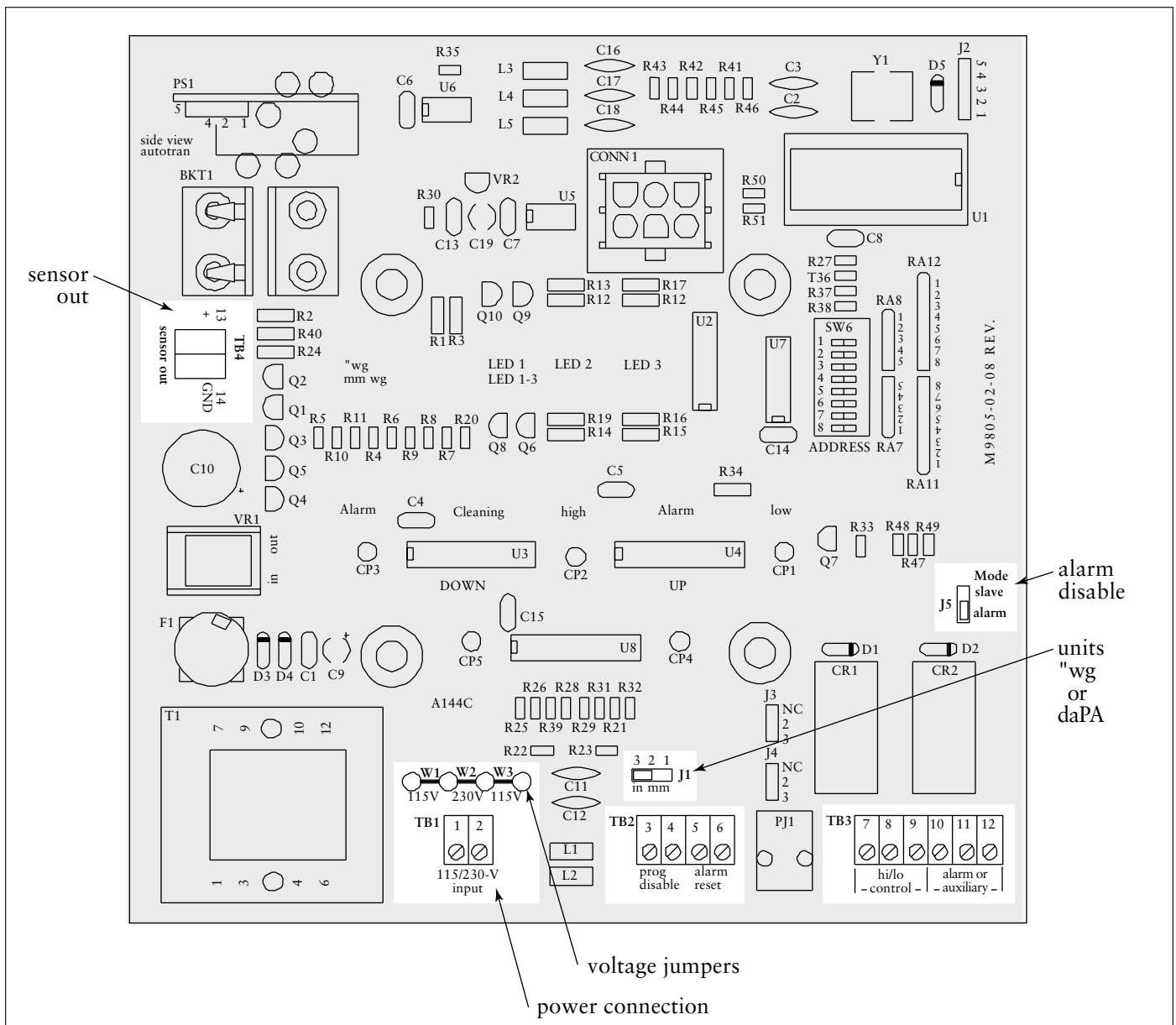

Delta P Control Printed Circuit Board

### **Optional Settings**

#### **230-V Power Supply**

To operate at 230-V, remove two jumpers labeled W1 and W3. Reinsert one of the jumpers in position W2.

#### **Change from English to Metric (SI) Units**

On the J1 jumper block located above the PROG DISABLE terminals, move the jumper from the center and left pins 2 and 3, to the center and right pins 1 and 2.

#### **Disable Setpoint Adjustment**

To restrict setpoint changes, install a jumper wire across the PROG DISABLE terminals on Terminal Block 2, TB2. The current settings can be displayed, but no changes can be made until the jumper is removed. A key-operated, normally-closed switch installed in the enclosure door will provide temporary access to the setting functions without opening the door.

#### **External Alarm Reset**

Wire the ARM RESET terminals on Terminal Block 2, TB2, to a key-operated, normally-open switch. Closing the switch turns the alarm OFF. If alarm conditions still exist, the alarm relay reactivates in 10 seconds.

#### **Alarm Disable**

Remove the jumper on Jumper Block J5 located on the lower-right quadrant of the circuit board, from the ALARM mode position.

1. Reinstall the jumper in the SLAVE mode position to operate the AUXILIARY relay in parallel with the HI/LO CONTROL relay.
2. The AUXILIARY relay will not function if no jumper is installed.

**Note:** Disabling the alarm relay reduces the alarm function to visual display only.

#### **Analog Output**

Locate the Sensor Out Terminal Block 4, TB4, in the upper-left quadrant of the circuit board. This connector provides a 1 to 5-Volt DC output proportional to the 0-to-maximum span of the pressure sensor. This circuit requires a 10,000-ohm load minimum.

### **Delta P Control Calibration**

The only user calibration is the zero adjustment of the display. Due to slight changes in electronic components over time, or pressure differentials within the plant environment, the display may read something other than 0.0 while at rest. Use the following procedure to recalibrate the operating system.

1. Turn power to the Delta P Control ON for a minimum of 30-minutes to stabilize the operating temperature.
2. Turn power to the control OFF.
3. **Press and hold** the LOW SET, HIGH SET, and ALARM SET keys while turning power to the control back ON. Continue holding the keys as the control goes through its power-up sequence. The number 8 is displayed in each digit, and then the display reads 0.0.
4. Release the three keys. The new calibration is automatically stored in memory.

## Damper Installation

A damper can be added to the power pack outlet to limit and regulate airflow when unit is in operation.

### Radial Blade

1. Apply 1/4-in diameter, rope-type sealant toward the inside edge of the bolt pattern on both sides of the spacer ring.
2. Position the spacer ring on the unit's clean-air outlet and align bolt patterns.
3. Apply silicone sealant, supplied with blower, around the blower outlet.
4. Slide the damper collar over the blower outlet and secure using four equally spaced self-drilling screws supplied.
5. Loosen the wing nut on the damper and adjust from 30 to 50% closed.

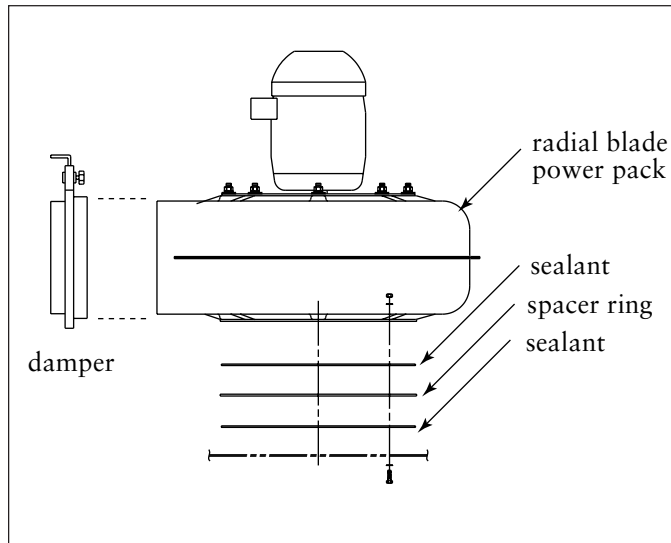

*Radial Blade Damper Installation*

### Backward Inclined

1. Apply sealant around the inside edge of the bolt pattern on the power pack outlet.
2. Fasten damper to the blower outlet using the hardware provided.

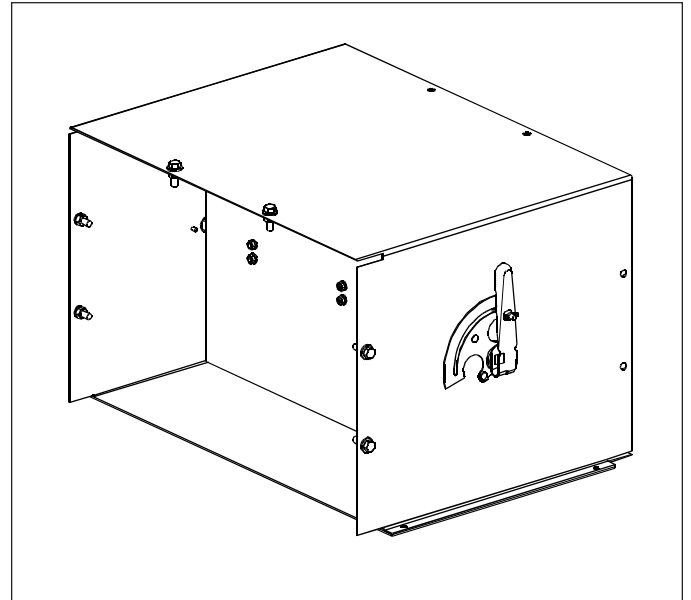

*Backward Inclined Damper Installation*

## Exhaust Grid Installation

### **Radial Blade**

1. Fit the exhaust grid over the radial blade outlet or the damper assembly, if equipped.
2. Fasten using three self-drilling screws supplied.

### **Backward Inclined**

1. Attach flanges to the backward inclined outlet using the fasteners supplied.
2. Fasten exhaust grid to flanges using the supplied fasteners.

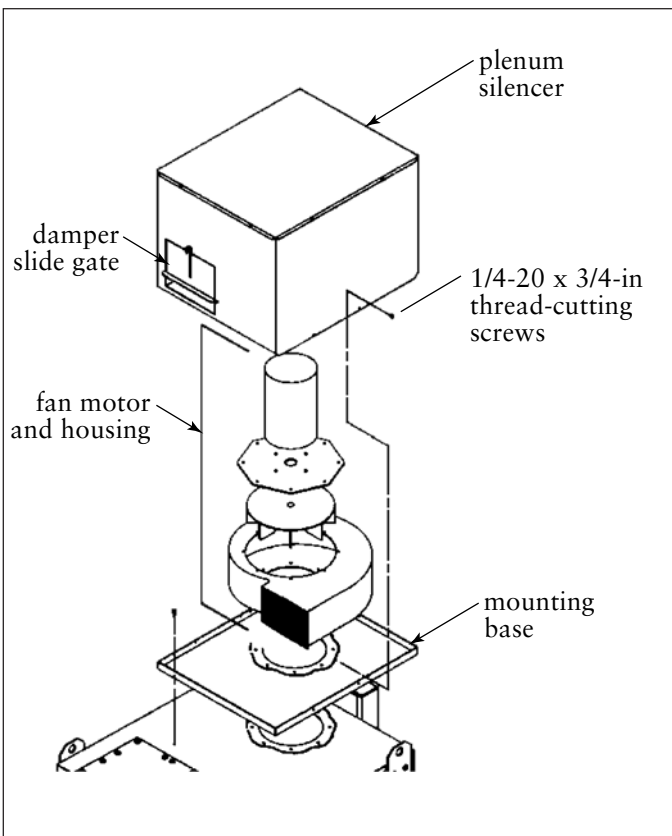

*Top Mount Blower and Silencer Installation*

## Plenum Silencer

### **Radial Blade and Backward Inclined**

1. Apply 1/4-in diameter, rope-type sealant towards the outside edge of the bolt pattern on the clean-air outlet.
2. Position the silencer's mounting base aligning the bolt patterns of the collector and the mounting base.
3. Apply 1/4-in diameter, rope-type sealant towards the outside edge of the bolt pattern on the silencer's mounting base.
4. Install the blower housing, align holes, and secure using the supplied hardware.
5. Assemble the remaining power pack components as described in Power Pack Installation on Page 10.
6. Attach the plenum silencer to the base using self-threading bolts with washers.
7. Route rigid or flexible conduit from the junction box on the motor to the outside wall of the silencer to house wiring.
8. Install the top of the silencer using the supplied hardware.
9. Loosen the wing nut on the damper and adjust from 30 to 50% closed.

## Exhaust Silencer

### *Backward Inclined Only*

1. Attach flanges to the power pack outlet using the supplied bolts, washers, and nuts.
2. Apply sealant to the flange and attach silencer to flange. Tighten all hardware.
3. Loosely assemble the silencer's support brackets.
4. Align the pivoting support brackets to extend a minimum of 30-inches from the collector and mark the drill locations.
5. Drill pilot holes with a 0.339-inch bit.
6. Secure brackets using 3/8-in thread-forming bolts.
7. If a gap exists between the silencer and the damper, install the filler panel using the screws provided.

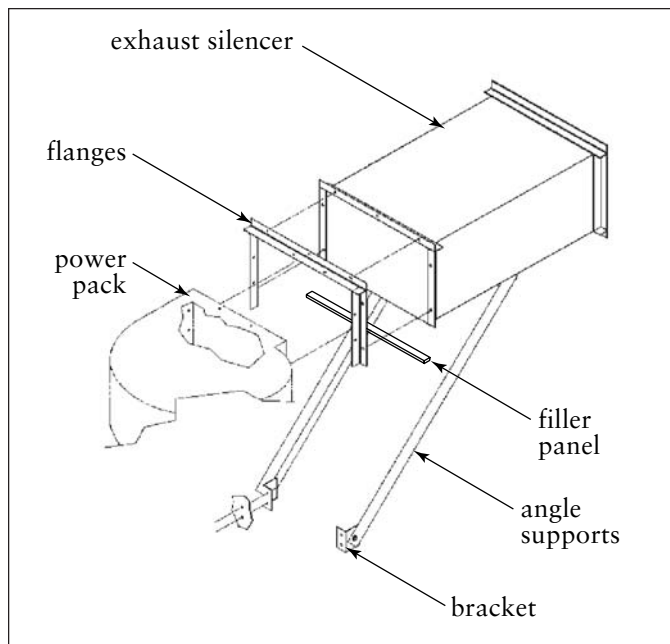

*Backward Inclined Exhaust Silencer*

## Abrasion-Resistant Inlet Collar

1. Remove the unit's front cover plate. Remove excess sealant from opening.
2. Apply 1/4-in sealant around the opening toward the inside-edge of the bolt pattern.
3. Align the holes on the inlet collar with the holes in the unit and secure using 3/8-16 x 1-in bolts and flat washers supplied.

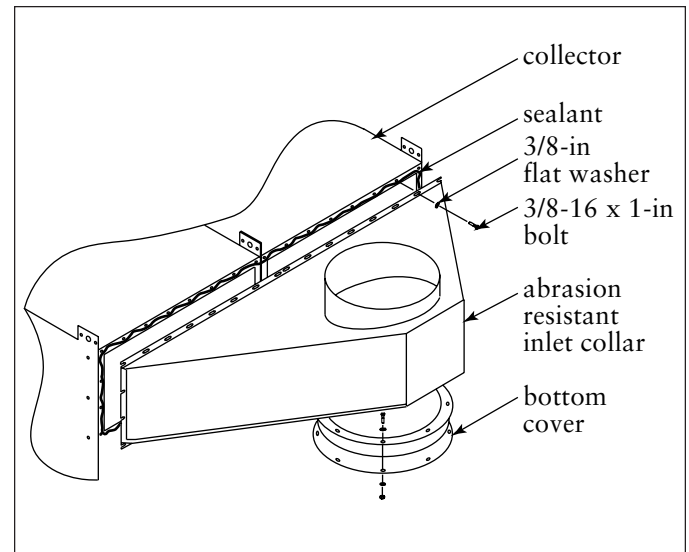

*Abrasion-Resistant Inlet Collar*

## HEPA or ASHRAE Afterfilter Installation

The afterfilter plenum is mounted on top of the unit and the blower is positioned inside the plenum.

1. Apply sealant around the clean-air outlet toward the outside edge of the bolt hole pattern located on the top of the collector.
2. Position the afterfilter plenum's mounting base aligning the bolt patterns.
3. Apply sealant to the plenum's mounting base toward the outside edge of the bolt pattern.
4. Install the blower housing, align bolt holes, and fasten securely in place using hardware supplied with the power pack.
5. Assemble the remaining power pack components as described in Power Pack Installation on Page 10.
6. Apply sealant to the inside perimeter of the mounting base. Install the plenum to the mounting base using self-threading bolts with washers.
7. Install 1/2-in conduit using the holes on the back of the afterfilter plenum. Flexible or rigid conduit can be used. Wire the fan motor as described in Checker Board Control Panel on Page 15.
8. Apply sealant to the plenum's top flange and use self-treading bolts and washers to secure the plenum top to the plenum.
9. Install the afterfilters in the afterfilter frames. Install HEPA filters with the gasket toward the inside of the frame. Install ASHRAE filters with the airflow direction arrow pointing outside.
10. Position the clamp straps and tighten the wing screws securely.

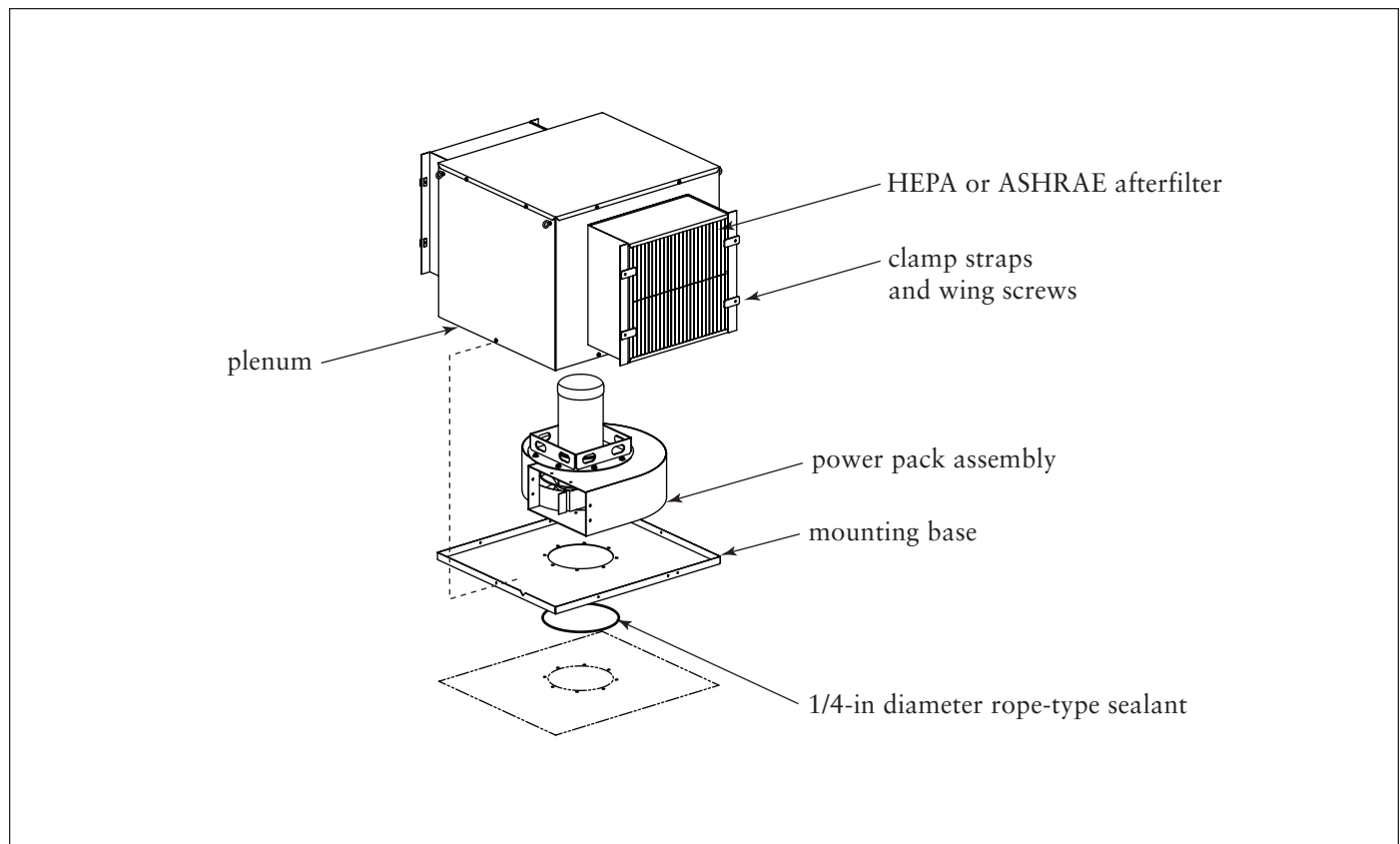

*HEPA/ASHRAE Afterfilter Installation*

## Cold Climate Kit

A cold climate kit provides heat to the pulse valves to prevent cold weather freeze up. The basic kit, for use in applications that have a moderate amount of moisture in the compressed-air supply, consists of a small heating element and thermostat installed in the solenoid enclosure. The basic kit is factory-installed and supplied with the appropriate solenoid wiring instructions.

A heavy-duty kit is available for applications that have moderate-to-high amounts of moisture in the compressed-air supply and consists of the basic kit plus a heat cable to deliver heat to the large pulse valves. This kit is customer installed and detailed installation instructions are provided.

1. Install the power connection kit on the heat cable following the manufacturer's instructions.
2. Start with the upper right-hand valve, wrap heat cable around the valve. Pull heat cable tight.

**Note:** Double wrap between the valve's mounting flange and the square valve cover.

3. Position a 3-in hose clamp around the double wrapped heat cable and tighten securely.
4. Wrap remaining valves the same way.
5. Drill a 1-in diameter hole in the back of the junction box. Assemble the power connection kit following the manufacturer's instructions.

6. Secure junction box to the collector using two self-drilling screws.
7. Wrap 6-ft of pipe insulation tape around each heat-cable wrapped valve. Wrap the entire valve, double wrapping the hose-clamped heat cable. Secure with cable ties.

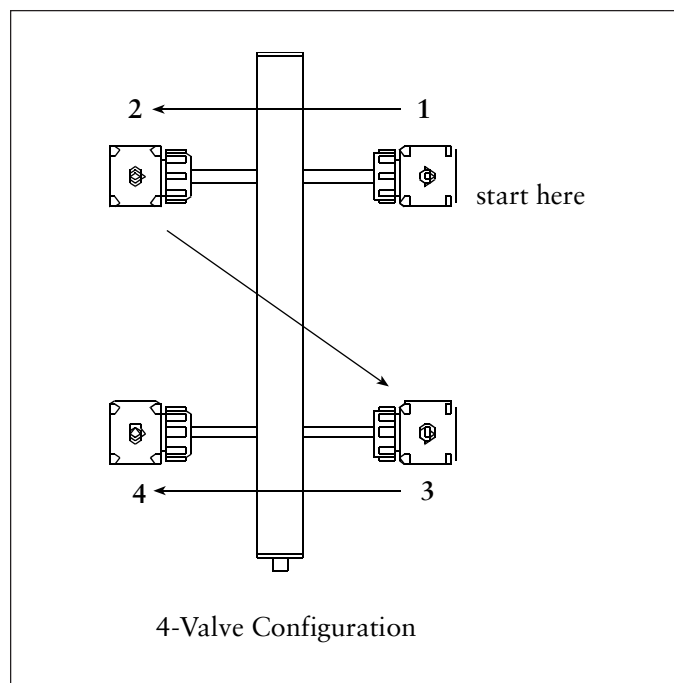

*Cold Climate Kit, Detail B*

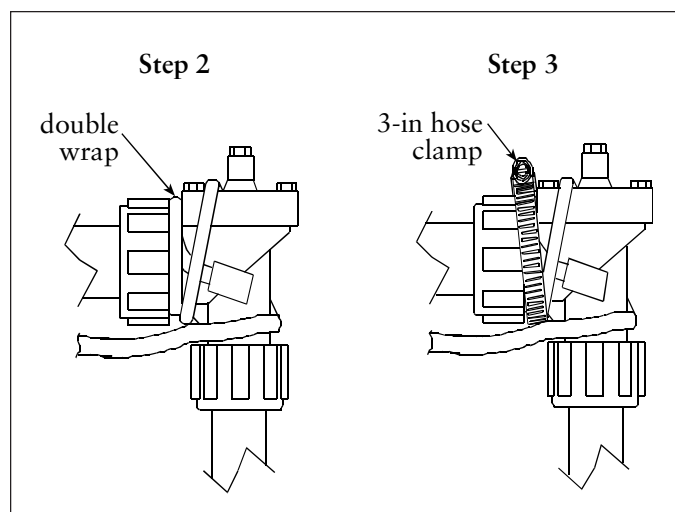

*Cold Climate Kit, Detail A*

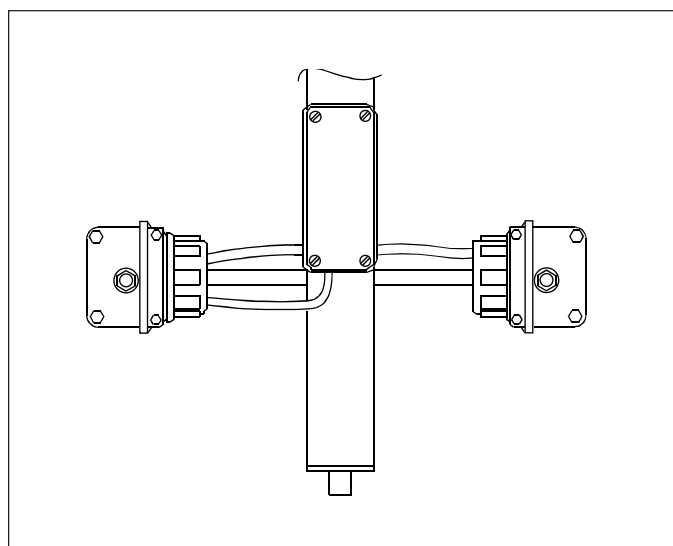

*Cold Climate Kit, Detail C*

## Drum Sentry™, Drum-Full Indicator

The Drum Sentry provides a visual readout of the 55-gallon drum contents. When the dust level in the drum covers the opening on the bottom of the Drum Sentry, the gauge indicator changes from E, empty to Full.

**Note:** Do not use the Drum Sentry on dust with low-bulk densities such as wood-dust shavings and cotton fibers.

1. Drill a 1 3/8-in diameter hole in the drum cover as shown in Detail A. Remove excess gasket material from the underside of the cover.
2. Apply silicone sealant to the top threads of the close nipple and thread into the gauge assembly hand tight.
3. Apply silicone sealant to the top of the drum cover around the 1 3/8-in diameter hole.
4. Place a 1/4-in thick washer on the close nipple and insert in 1 3/8-in diameter hole.
5. Apply silicone sealant to the underside of the drum cover around the 1 3/8-in diameter hole and the threads of the close nipple.
6. Place a 1/4-in thick washer on the close nipple and thread the coupling on.
7. Use a pipe wrench to tighten coupling until the washers engage the drum cover. The gauge assembly should stand firmly upright.
8. Apply silicone sealant to the treads of the nylon barbed nipple and thread onto the coupling hand tight.

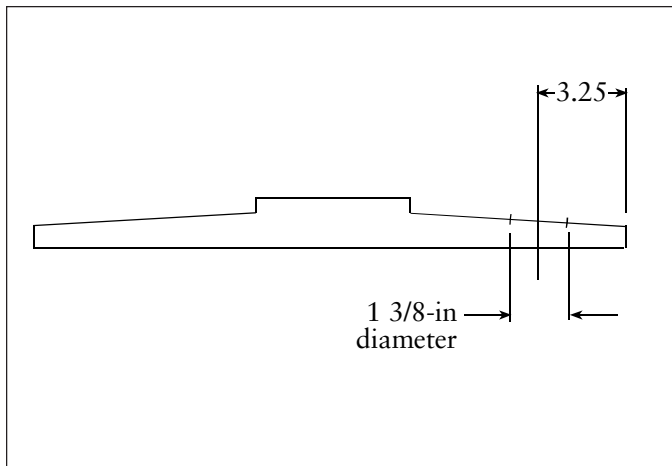

*Drum Sentry Step 1*

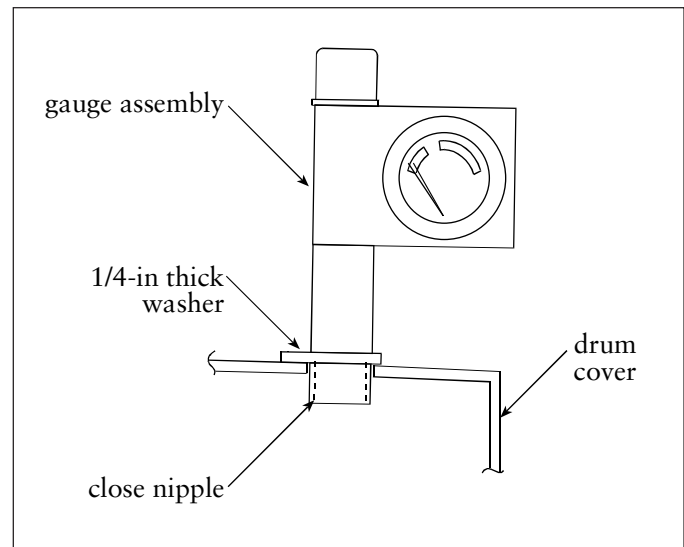

*Drum Sentry Step 4*

9. Trim the 1-in diameter hose to extend into the drum at the desired drum-full level.

**Note:** Dust with low-bulk density such as weld fume require the hose to be immersed a minimum of 6-in.

10. Place the cover on the drum and position under hopper.
11. Splice into the dirty-air plenum's air tubing and insert the nylon barbed tee.
12. Install 3/16-in diameter tubing between the open branch of the tee and the center barbed fitting on the gauge assembly. Trim excess tubing.

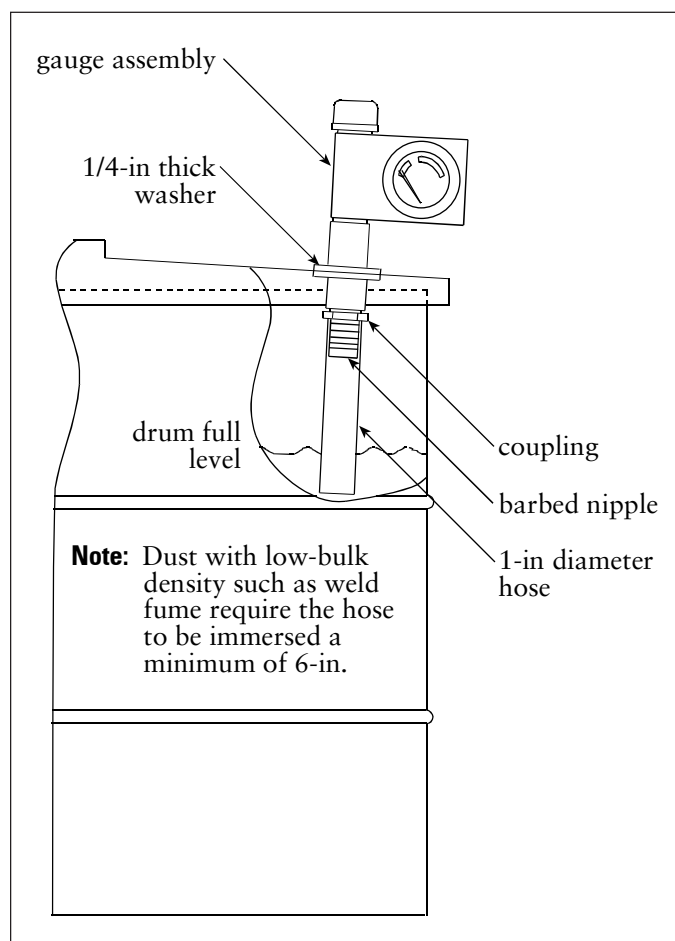

*Drum Sentry Step 9*

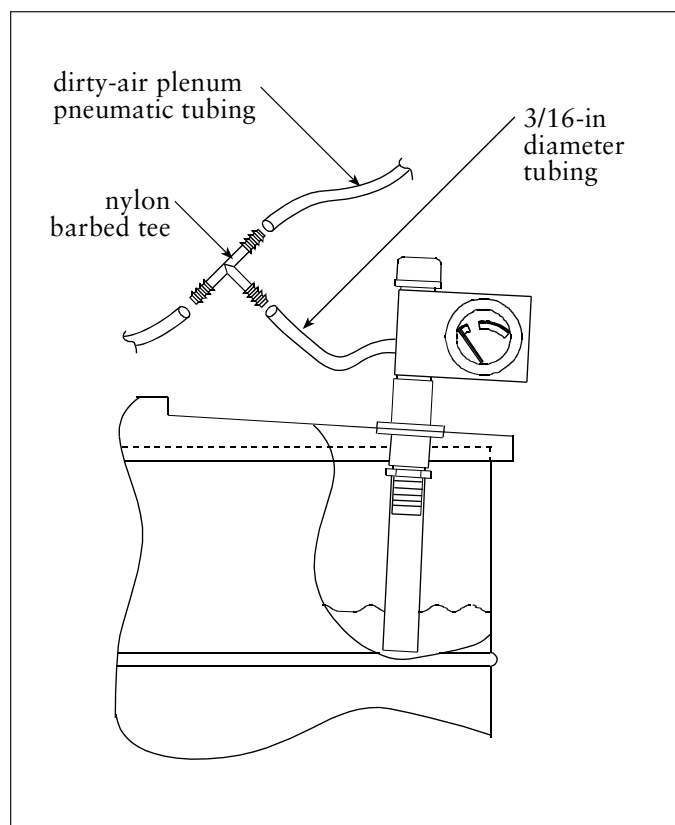

*Drum Sentry Step 11*

## Sprinkler Installation



### Caution!

Sprinkler systems place a large quantity of water in the dust collector when activated. Provide adequate drainage to remove water. Excess water weight can cause the leg structure to collapse.

Optional fire control sprinklers are available for all models operating under negative pressure. Torit-supplied sprinklers require a minimum of 15-psig water pressure to each module. The volume of water discharged per sprinkler head is 17 gallons per minute.

**Note:** Consult with local authorities when installing fire control systems on dust collection equipment.

1. Remove the top filter access doors and filters to access the sprinkler taps located in the dirty-air plenum.
2. Apply pipe sealant to the threads of the pipe reducer located on the sprinkler assembly.
3. Thread sprinkler assembly onto the 1-in diameter sprinkler tap.
4. Tighten securely.

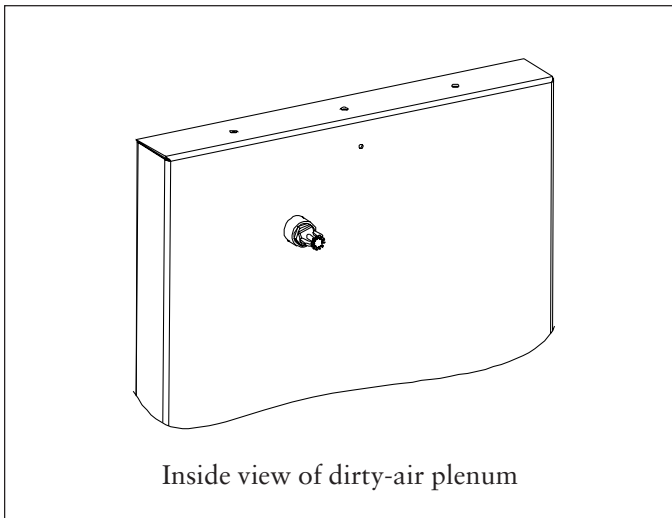

*Sprinkler Installation*

## Explosion Vents



### Caution!

- Personal injury, death, or property damage can result from material discharge during venting.
- The material discharged from an enclosure during the venting of an explosion should be directed safely to an outside location.
- The risk of damage or injury can be minimized or avoided by locating vented equipment outside buildings and away from normally occupied areas.
- Standard explosion vents are intended for outdoor installations only.

- Explosion relief vents must be safely directed outdoors away from personnel, buildings, property, offices, walkways, and catwalks to reduce risk of damage to property and personal injury. Explosion venting calculations are based on formulas from NFPA-68, 1998 for outdoor applications only, with no duct or obstructions on the explosion vent panel.
- Explosion vents are suitable for negative pressure installations only.
- Contact Donaldson for assistance in calculating safe and specific venting requirements for Torit equipment.

## Service Information

### Operational Checklist

1. Monitor overall performance of the collector.
2. Monitor exhaust.
3. Monitor pressure drop across filters.
4. Monitor dust disposal.

### Filter Installation and Replacement

#### Filter Removal



#### Caution!

- Use proper safety and protective equipment when removing contaminants and filters.
- Dirty filters may be heavier than they appear.
- Use care when removing filters to avoid personal injury.
- Do not drop filters.

1. Turn power to unit OFF.
2. Start at the top access port.
3. Remove access cover by turning knob counterclockwise.
4. Break the seal between the filter cartridge and the sealing surface.
5. Slowly rotate the cartridge 1/2-turn to remove dust that may have accumulated on the top of the filter.
6. Slide the filter out the access port along the suspension yoke.
7. Dispose of properly.
8. Clean the sealing surface with damp cloth.

**Note:** Clean dust from gasket sealing area to ensure a positive filter gasket seal.

9. Check for an accumulation of dust in the storage area and empty as necessary.

#### Filter Replacement

**Note:** Place filter part-number label (supplied with each replacement filter) over the filter part number listed on the unit's rating plate.

1. Slide the new filter cartridge onto each suspension yoke.

**Note:** Insert the filter gasket-end first.

2. Wipe cover gaskets clean and replace covers by attaching cover to yoke hook and firmly latching cover handle.

**Note:** Check that access covers are seated and seal properly. Gaskets must be compressed to ensure an air tight seal.

3. Turn electrical power and compressed air supply ON before starting unit.

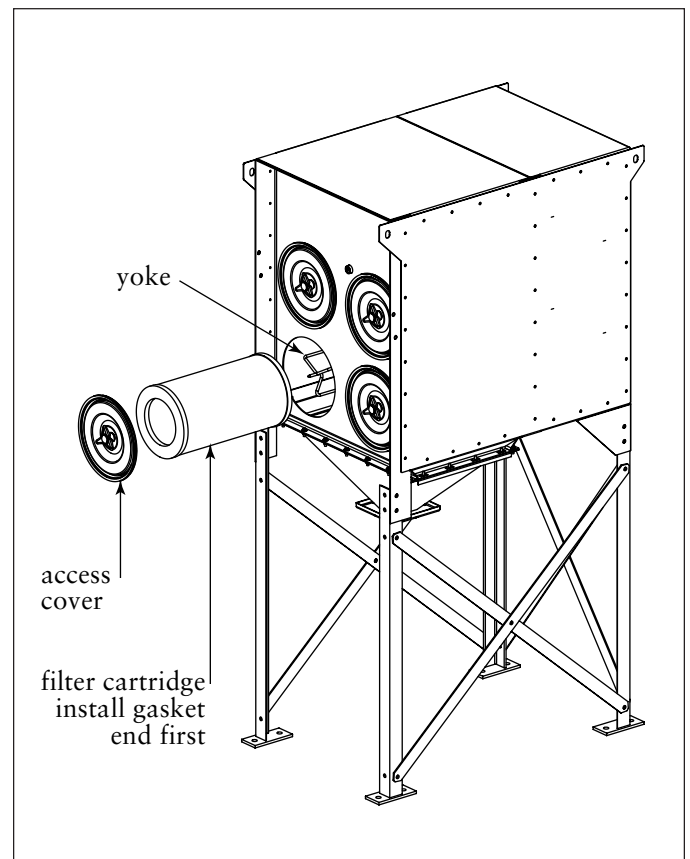

*Filter Installation and Replacement*

## Dust Disposal

1. Turn unit OFF and empty dust container as necessary to minimize dust in the hopper.
2. If the optional 55-gallon drum attachment is used, empty when drum is 2/3 full.
3. If optional slide gate is used, close gate before servicing drum.
4. Reinstall drum and open gate.

## Compressed Air Components



### Caution!

Turn compressed-air supply OFF and bleed lines before performing service work.

1. Periodically check the compressed air components and replace compressed-air filters.
2. Drain moisture following the manufacturer's instructions.
3. With the compressed-air supply ON, check the cleaning valves, solenoid valves, and tubing for leaks. Replace as necessary.

## Troubleshooting

<b>Problem</b>	<b>Probable Cause</b>	<b>Remedy</b>
<b>Blower fan and motor do not start</b>	Improper motor wire size	Rewire using the correct wire gauge as specified by national and local codes.
	Not wired correctly	Check and correct motor wiring for supply voltage. See motor manufacturer's wiring diagram. Follow wiring diagram and the National Electric Code.
	Unit not wired for available voltage	Correct wiring for proper supply voltage.
	Input circuit down	Check power supply to motor circuit on all leads.
<b>Blower fan and motor start, but do not stay running</b>	Electrical supply circuit down	Check power supply circuit for proper voltage. Check for fuse or circuit breaker fault. Replace as necessary.
	Incorrect motor-starter installed	Check for proper motor starter and replace if necessary.
	Access doors are open or not closed tight	Close and tighten access doors. See Filter Installation on Page 38.
	Hopper discharge open	Install slide gate or drum cover arrangement to hopper discharge. See Hopper Installation on Page 8.
	Blower fan damper control not adjusted properly	Check airflow in duct. Adjust damper control until proper airflow is achieved and the blower-motor's amp draw is within the manufacturer's rated amps.
<b>Clean-air outlet discharging dust</b>	Electrical circuit overload	Check that the power supply circuit has sufficient power to run all equipment.
	Filter cartridges not installed correctly	See Filter Installation on Page 38.
	Filter cartridge damage, dents in the end caps, gasket damage or holes in pleated media	Replace filters as necessary. Use only genuine Donaldson replacement parts. See Filter Installation on Page 38.
<b>Insufficient airflow</b>	Access cover(s) loose	Tighten access doors securely. See Filter Installation on Page 38.
	Fan rotation backwards	Proper fan rotation is clockwise when looking down at the blower motor. See Preliminary Start-Up Check on Page 20.

## Troubleshooting, continued

<b>Problem</b>	<b>Probable Cause</b>	<b>Remedy</b>
<b>Insufficient airflow continued</b>	Access doors open or not closed tight	Check that all access doors are in place and secured. Check that the hopper discharge opening is sealed and that optional attachments are installed correctly. See Hopper Installation on Page 8.
	Fan exhaust area restricted	Check fan exhaust area for obstructions. Remove material or debris. Adjust damper flow control.
	Filter cartridges need replacement	Remove and replace using genuine Donaldson replacement filters. See Filter Installation on Page 38.
	Lack of compressed air	Check that a minimum of 90-psig is available. See Compressed Air Installation on Page 18.
	Pulse cleaning not energized	Use a voltmeter to check supply voltage to the timer board. Check and replace the fuse on the timer board if necessary. See Solid-State Timer Installation on Page 12.
	Dust storage area overfilled or plugged	Clean out dust storage area. See Dust Disposal on Page 41.
	Pulse valves leaking compressed air	Lock out all electrical power to the unit and bleed the compressed-air supply. Check for debris, valve wear, or diaphragm failure by removing the diaphragm cover on the pulse valves. Check for solenoid leaks or damage. If pulse valves or solenoid valves and tubing are damaged, replace.
	Solid-State Timer failure	Using a voltmeter, check supply voltage to the timer board. Check and replace the fuse on the timer board if necessary. If the fuse is good and input power is present, but output voltage to the solenoid valves is not, replace the timer board. See Solid-State Timer Installation on Page 12.
	Solid-State Timer out of adjustment	See Solid-State Timer and Solid-State Timer Wiring Diagram.
<b>No display on the Delta P control</b>	No power to the control	Use a voltmeter to check for voltage at Terminal TB1.
	Fuse blown	Check the fuse in the F1 fuse tower. Replace if necessary.

<b>Problem</b>	<b>Probable Cause</b>	<b>Remedy</b>
<b>Display on Delta P control does not read zero when at rest</b>	Out of calibration	Disconnect pressure tubing. See Delta P Control on Page 28.
	With collector discharging outside, differential pressure is present from indoor to outdoor	Recalibrate with the pressure tubing attached as described in the Delta P Control section on Page 28.
<b>Delta P control ON, but cleaning system does not start</b>	Not wired to the timing board correctly	Connect the pressure switch on the timer board to Terminals 7 and 8 on TB3.
	Faulty relay	Using a multimeter, test relay for proper closure. Replace if necessary.
	Pressure tubing disconnected, ruptured, or plugged	Check tubing for kinks, breaks, contamination, or loose connections.
<b>Pulse-cleaning never stops</b>	Pressure switch terminals on the timer board jumpered	Remove jumper wire on solid-state timer board before wiring to the Delta P control.
	Pressure switch not wired to the timer board correctly	Connect the pressure switch on the timer board to Terminals 7 and 8 on TB3.
	High or low setpoint not adjusted for system conditions	Adjust setpoints to current conditions.
	Pressure tubing disconnected, ruptured, or plugged	Check tubing for kinks, breaks, contamination, or loose connections.
<b>Alarm light is ON</b>	Alarm setpoint too low	Adjust to a higher value.
	Excess pressure drop	Check cleaning system and compressed-air supply. Replace filter cartridges if filters do not clean down.
	Pressure tubing disconnected, ruptured or plugged	Check tubing for breaks, contamination, or loose connections.
<b>Delta P arrow keys do not work</b>	Improper operation	Press and hold one of the three setpoint keys to use arrow keys.
	Programming keys disabled	Remove the Program Disable jumper from Terminals 3 and 4 on TB2.

## Troubleshooting, continued

Problem	Probable Cause	Remedy
Cleaning light is ON, but cleaning system not functioning	Improper wiring	Check wiring between the Delta P Control and the timer board, and between the timer board and solenoid valve coils.
	Defective solenoids	Check all solenoid coils for proper operation.
	Timer board not powered	Check power ON light on timer board's LED display. If not illuminated, check the supply voltage to the timer board. Check the fuse on the timer board. Replace if necessary.
	Timer board defective	If LED is illuminated, observe the output display. Install a temporary jumper across the pressure switch terminals. Output levels should flash in sequence. Check output using a multimeter set to 150-Volt AC range. Measure from SOL COM to a solenoid output. The needle will deflect when LED flashes for that output if voltage is present. If LED's do not flash, or if no voltage is present at output terminals during flash, replace the board.







## The Donaldson Torit Warranty

Donaldson warrants to the original purchaser that the major structural components of the goods will be free from defects in materials and workmanship for ten (10) years from the date of shipment, if properly installed, maintained and operated under normal conditions. Donaldson warrants all other Donaldson built components and accessories including Donaldson Airlocks, TBI Fans, TRB Fans, Fume Collector products, Donaldson built electrical control components and Donaldson built Afterfilter housings for twelve (12) months from date of shipment. Donaldson warrants Donaldson built filter elements to be free from defects in materials and workmanship for eighteen (18) months from date of shipment. Donaldson does not warrant against damages due to corrosion, abrasion, normal wear and tear, product modification, or product misapplication. Donaldson also makes no warranty whatsoever as to any goods manufactured or supplied by others including electric motors, fans and control components. After Donaldson has been given adequate opportunity to remedy any defects in material or workmanship, Donaldson retains the sole option to accept return of the goods, with freight paid by the purchaser, and to refund the purchase price for the goods after confirming the goods are returned undamaged and in usable condition. Such a refund will be in the full extent of Donaldson's liability. Donaldson shall not be liable for any other costs, expenses or damages whether direct, indirect, special, incidental, consequential or otherwise. The terms of this warranty may be modified only by a special warranty document signed by a Director, General Manager or Vice President of Donaldson. Failure to use genuine Donaldson replacement parts may void this warranty. THERE EXIST NO OTHER REPRESENTATIONS, WARRANTIES OR GUARANTEES EXCEPT AS STATED IN THIS PARAGRAPH AND ALL OTHER WARRANTIES INCLUDING MERCHANTABILITY AND FITNESS FOR A PARTICULAR PURPOSE, WHETHER EXPRESS OR IMPLIED ARE HEREBY EXPRESSLY EXCLUDED AND DISCLAIMED.

### Parts and Service

For genuine Donaldson Torit replacement filters  
and parts, call the Parts Express Line

**800-365-1331 USA**

**800-343-3639 within Mexico**

**[www.donaldsontorit.com](http://www.donaldsontorit.com)**

For faster service, have unit's model and serial number,  
part number, description, and quantity available.



Donaldson Company, Inc.  
Industrial Air Filtration  
P.O. Box 1299  
Minneapolis, MN 55440-1299  
[donaldsontorit@donaldson.com](mailto:donaldsontorit@donaldson.com)

Donaldson Company, Inc. is the leading designer and manufacturer of dust, mist, and fume collection equipment used to control industrial-air pollutants. Our equipment is designed to help reduce occupational hazards, lengthen machine life, reduce in-plant maintenance requirements, and improve product quality.