

# Installation and Operation Manual

## Downdraft Bench Model DB-800



This is the safety alert symbol. It is used to alert you to potential personal injury hazards. Obey all safety messages that follow this symbol to avoid possible injury or death.

*Illustrations are for reference only  
as actual product may vary.*

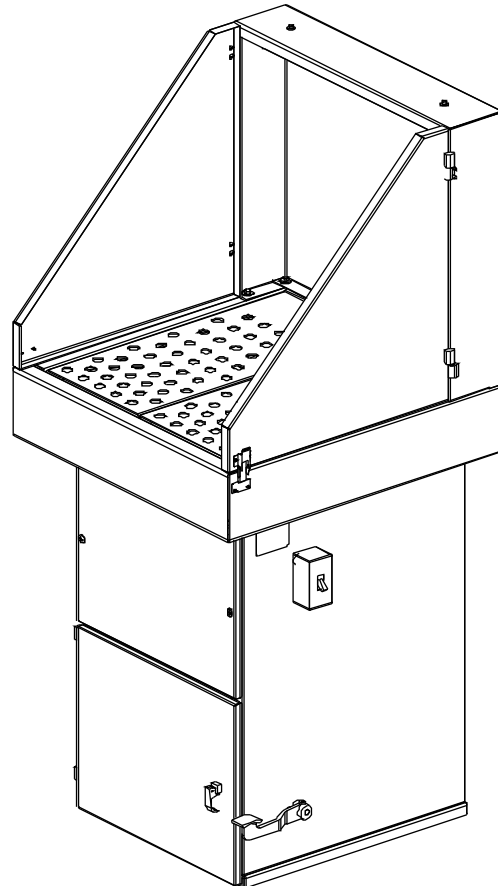

This manual is property of the owner. Leave with the unit when set-up and start-up are complete. Donaldson Company reserves the right to change design and specifications without prior notice.



## **APPLICATION OF DUST CONTROL EQUIPMENT**

Combustible materials such as buffing lint, paper, wood, metal dusts, weld fume, or flammable coolants or solvents represent potential fire and/or explosion hazards. Use special care when selecting, installing, and operating all dust, fume, or mist collection equipment when such combustible materials may be present in order to protect workers and property from serious injury or damage due to a fire and/or explosion.

Consult and comply with all National and Local Codes related to fire and/or explosion properties of combustible materials when determining the location and operation of all dust, fume, or mist collection equipment.

When combustible materials are present you must consult with an expert in fire extinguishing and/or explosion protection systems, who is also familiar with the local codes, for support and guidance on the selection and installation of an appropriate fire and/or explosion protection system.

DO NOT allow sparks, cigarettes or other burning objects to enter the hood or duct of any dust, fume, or mist collection equipment as these may initiate a fire or explosion of any combustible materials accumulated in the collector.

Portions of dust, mist, and fume-collection equipment, including the clean- and dirty-air plenums may be considered “OSHA Confined Spaces.” Refer to the appropriate OSHA regulations to determine if a specific installation should be considered a confined space and if a permit program is required.

Improper operation of a dust, fume, or mist control system may contribute to conditions in the work area or facility that could result in severe personal injury and product or property damage. Check that all dust, fume, or mist collection equipment is properly selected, installed, and operated for its intended use.

This manual contains specific precautionary statements relative to worker safety. Read this manual thoroughly and comply as directed. Instruct all personnel on the safe use and maintenance procedures related to this equipment. Discuss any questions on the application, use, or maintenance of this equipment with a Donaldson Torit representative.

For optimum collector performance, use only Donaldson Torit replacement parts.

---

**Contents**

Description.....	1	Operational Checklist .....	8
Purpose and Intended Use .....	1	Dust Disposal.....	8
Operation.....	2	EZ Filter Maintenance .....	8
Inspection on Arrival.....	3	EZ Filter Pack Installation Instructions .....	9
Installation Codes and Procedures.....	3	Optional Equipment.....	11
Installation .....	3	Magnehelic® Gauge .....	11
Site Selection .....	3	Work Surface Rubber Mat .....	13
Unit Location .....	3	Automatic Shaker.....	13
Hoisting Information .....	4	Troubleshooting .....	17
Electrical Wiring .....	4	Service Notes.....	19
Standard Equipment.....	5		
Industrial Light, Three-Phase Units .....	6		
Hinged Side Panels .....	6		
Start-Up .....	7		
Maintenance Information.....	7		

Magnehelic® is a registered trademark of Dwyer Instruments, Inc.



**DANGER** indicates a hazardous situation which, if not avoided, will result in death or serious injury.



**WARNING** indicates a hazardous situation which, if not avoided, could result in death or serious injury.



**CAUTION**, used with the safety alert symbol, indicates a hazardous situation which, if not avoided, could result in minor or moderate injury.



**NOTICE** is used to address practices not related to personal injury.

**Data Sheet**

Model Number _____	Serial Number _____
Ship Date _____	Installation Date _____
Customer Name _____	
Address _____	
_____	
Filter Type _____	
Accessories _____	
Other _____	

## Description

The Downdraft Bench, Model DB-800 is a self-contained, intermittent-duty dust collector with envelope-style filters. Designed as a workstation for grinding, polishing, hand sanding, and dry buffing applications, the DB-800 features cotton sateen filter bags, prewired controls, and a fluorescent light fixture.

Direct-drive, forward-curve fan provides 200-fpm minimum face velocity across the slotted-steel work surface designed to hold up to 50-lb per square foot. Hinged side panels open to accommodate larger work pieces and a manually operated filter shaker allows on-demand filter cleaning. Replace filters easily with the one-piece EZ Filter Pack™ and dispose of dust contained in the dust drawer from the front of the unit.

## Purpose and Intended Use



Misuse or modification of this equipment may result in personal injury.

Do not misuse or modify.

The Downdraft Bench provides excellent efficiency on nuisance dust generated in industrial operations, such as grinding, buffing and polishing without rouge, and hand-sanding operations.

**Grinding:** The Downdraft Bench has a baffle that limits particles from directly impinging with the filter bags reducing the risk of bag damage.

**Buffing and Polishing:** Buffing and polishing operations without rouges.

**Hand Sanding:** Light-duty hand sanding only. Avoid applications with explosive dust or welding operations.

**Explosive Dust:** Not intended for use with explosive dust.

**Welding:** Not recommended for welding operations due to the natural tendency for weld fumes to rise and Downdraft Benches develop a downward airflow. Use the Donaldson Torit Weld Bench in these operations.



Combustible materials such as buffing lint, paper, wood, metal dusts, weld fume, or flammable coolants or solvents represent potential fire and/or explosion hazards. Use special care when selecting, installing, and operating all dust, fume, or mist collection equipment when such combustible materials may be present in order to protect workers and property from serious injury or damage due to a fire and/or explosion.

Consult and comply with all National and Local Codes related to fire and/or explosion properties of combustible materials when determining the location and operation of all dust, fume, or mist collection equipment.

Standard Donaldson Torit equipment is not equipped with fire extinguishing or explosion protection systems.

**Operation**

During normal operation, dust-laden air enters the DB-800 through the slotted-steel work surface. Heavy particulate falls into the dust drawers and fine particulate collects on the outside surface of the filter bags. Clean, filtered air passes through the center of the EZ Filter Pack™ into the clean-air chamber, and discharges through the clean-air outlet.

Model DB-800 is an intermittent-duty collector, which means that filter cleaning cannot start until the fan is turned OFF and fan rotation has stopped. Pushing down on the hand- or foot-operated shaker pedal and releasing rapidly six times completes manual filter cleaning. The releasing action causes the dust cake to fracture and fall into the dust storage area. Motorized filter shakers are optional and automatically clean the filters each time the unit is turned OFF.

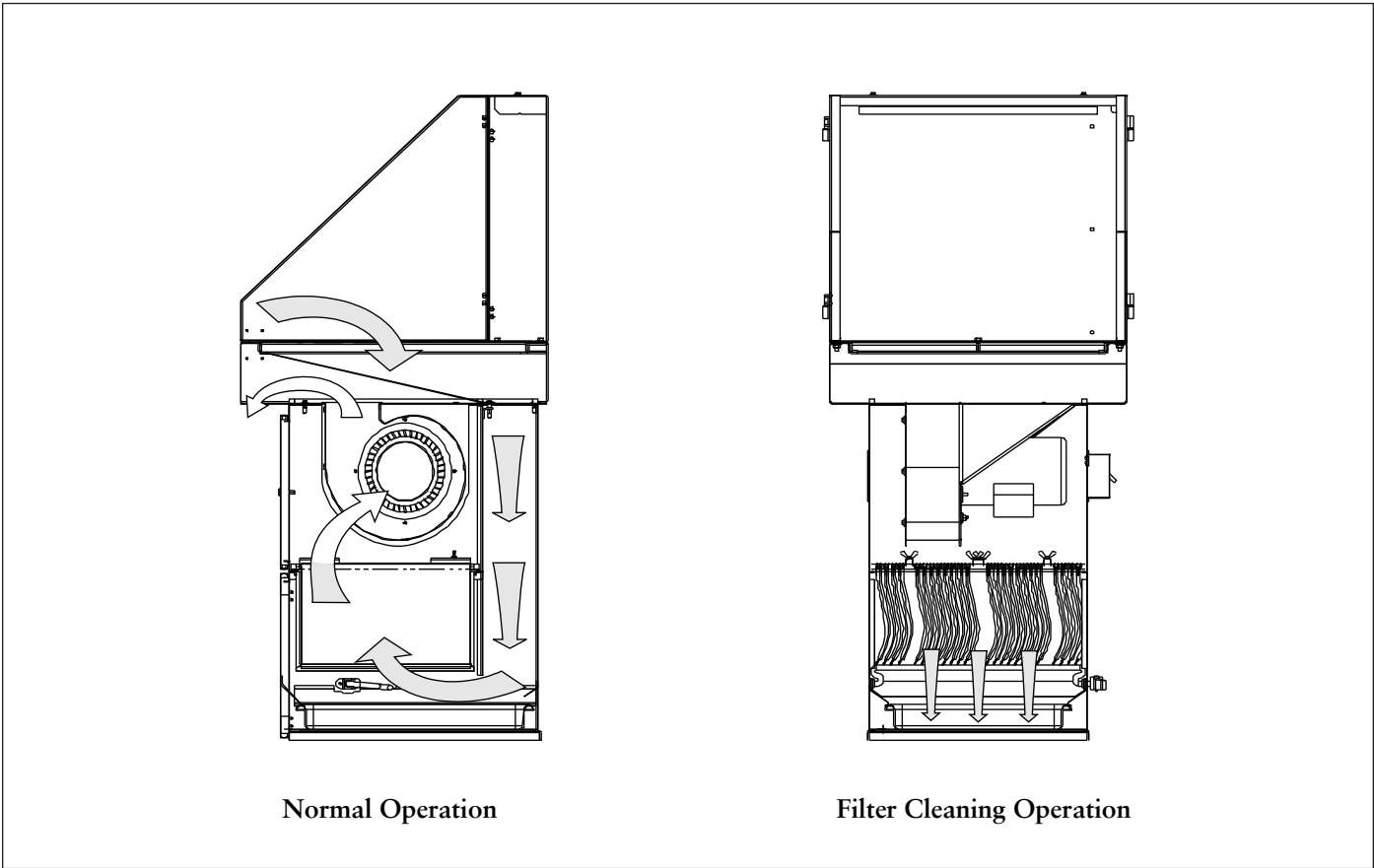

*Unit Operation*

## Inspection on Arrival

1. Inspect unit on delivery.
2. Report any damage to the delivery carrier.
3. Request a written inspection report from the Claims Inspector to substantiate claim.
4. File claims with the delivery carrier.
5. Compare unit received with description of product ordered.
6. Report incomplete shipments to the delivery carrier and your Donaldson representative.
7. Remove crates and shipping straps. Remove loose components and accessory packages before lifting unit from truck.
8. Check for hardware that may have loosened during shipping.
9. Use caution removing temporary covers.

## Installation Codes and Procedures

**CAUTION** OSHA may have requirements regarding recirculating filtered air in your facility. Consult with the appropriate local authorities to ensure compliance with all codes regarding recirculating filtered air.

Safe and efficient operation of the unit depends on proper installation.

Authorities with jurisdiction should be consulted before installing to verify local codes and installation procedures. In the absence of such codes, install unit according to the National Electric Code, NFPA No. 70-latest edition.

A qualified installation and service agent must complete installation and service of this equipment.

All shipping materials, including shipping covers, must be removed from the unit prior to, or during unit installation.

**NOTICE** Failure to remove shipping materials from the unit will compromise unit performance.

## Installation

### Site Selection

The unit should be located on a secure, level surface capable of supporting the weight of the unit and the weight of materials placed on the unit.

The DB-800 is a self-contained unit and requires no special installation accommodations.

### Unit Location

**WARNING** Donaldson Torit equipment is not designed to support site-installed ducts, interconnecting piping, or electrical services. All ducts, piping, or electrical services supplied by others must be adequately supported to prevent severe personal injury and/or property damage.

When hazardous conditions or materials are present, consult with local authorities for the proper location of the collector.

Locate the collector to ensure easy access to electrical and compressed-air connections and routine maintenance.

## Hoisting Information



Failure to lift the collector correctly can result in severe personal injury or property damage.

Lift unit from the bottom.

Use appropriate lifting equipment and adopt all safety precautions needed for moving and handling the equipment.

A forklift is recommended for unloading, assembly, and installation of the collector.

Location must be clear of all obstructions, such as utility lines or roof overhang.

Allow only qualified lift operators to lift the equipment.

Refer to applicable OSHA regulations and local codes when using cranes, forklifts, and other lifting equipment.

## Electrical Wiring



Electrical installation must be performed by a qualified electrician and comply with all applicable national and local codes.

Lock out electrical power sources before performing service or maintenance work.

Do not install in classified hazardous atmospheres without an enclosure rated for the application.

All electrical wiring and connections, including electrical grounding, should be made in accordance with the National Electric Code and NFPA No. 70-latest edition.

Check local ordinances for additional requirements that apply.

The appropriate wiring schematic and electrical rating must be used. See unit's rating plate for required voltage.

If the unit is not furnished with a factory-mounted disconnect, an electric disconnect switch having adequate amp capacity shall be installed in accordance with Part IX, Article 430 of the National Electrical Code and NFPA No. 70-latest edition. Check unit's rating plate for voltage and amperage ratings.

Refer to the wiring diagram for the number of wires required for main power wiring and remote wiring.

## Standard Equipment

Standard equipment consists of a self-contained unit housing the filters, blower, clean- and dirty-air chambers, and dust drawers.

### **WARNING**

Electrical installation must be performed by a qualified electrician and comply with all applicable national and local codes.

Turn power off and lock out electrical power sources before performing service or maintenance work.

Do not install in classified hazardous atmospheres without an enclosure rated for the application.

1. Make the electrical connections to the customer-supplied safety disconnect switch, blower, and blower starter.
2. Turn power ON at source.
3. Turn the blower motor ON then OFF to check for proper rotation by referencing the rotation arrow located on the blower housing. A blower running in the wrong direction will still deliver approximately 40% of its rated air volume making proper rotation extremely important.

#### **To reverse rotation, single-phase power supply:**

Follow manufacturer's instructions on the motor's nameplate.

#### **To reverse rotation, three-phase power supply:**

Turn electrical power OFF at source and switch any two leads on the output-side of the fan-motor starter.

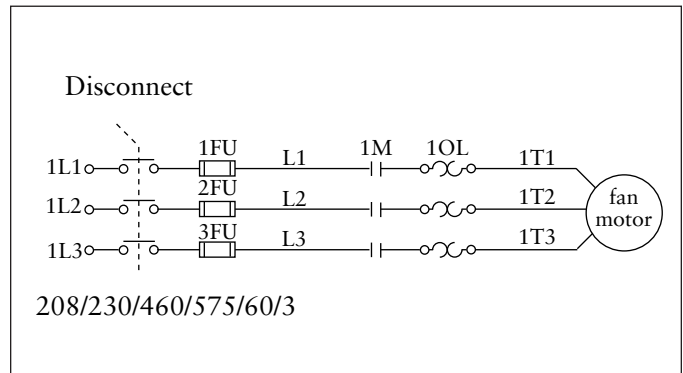

*Motor Starter Wiring Diagram*

**Industrial Light, Three-Phase Units**

- 1. Wire the light fixture to a 120-Volt power supply.
- 2. Install customer-supplied fluorescent bulbs.

**Hinged Side Panels**

The DB-800 is equipped with a right and left, lift-off hinged side panels. Open or remove panels when working with items too large or awkward for the work surface. Keep the panels closed under normal operating conditions.

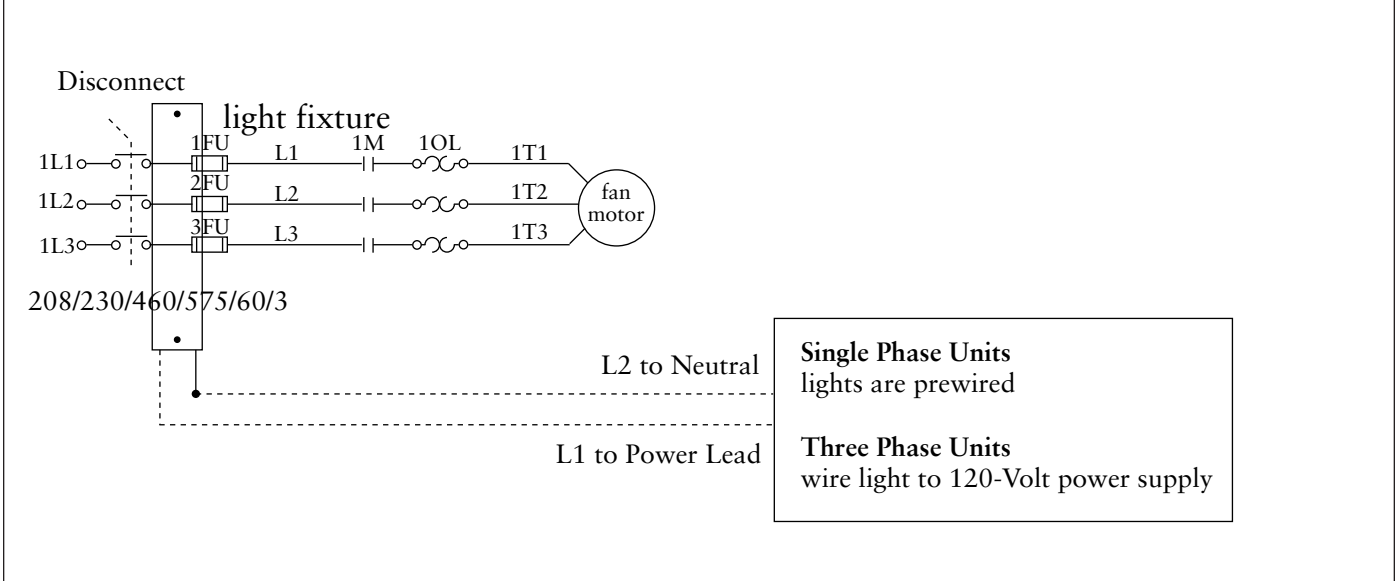

*Light Fixture Wiring*

## Preliminary Start-Up Check

Instruct all personnel on safe use and maintenance procedures.

### **WARNING**

Electrical installation must be performed by a qualified electrician and comply with all applicable national and local codes.

Turn power off and lock out electrical power sources before performing service or maintenance work.

Check that the collector is clear and free of all debris before starting.

Do not install in classified hazardous atmospheres without an enclosure rated for the application.

1. Check all electrical connections for tightness and contact.
2. Check for and remove all loose items in or near the inlet and outlet of the unit.
3. Check that all remote controls are wired into the control system, and all service switches are in the OFF position.
4. Check that all optional accessories are installed properly and secured.
5. Turn power ON at source.
6. Turn the fan motor ON then OFF to check for proper rotation by referencing the rotation arrow located on the motor's mounting plate.

### **WARNING**

Do not look into fan outlet to determine rotation. View the fan rotation through the back of the motor.

Check that the exhaust plenum is free of tools or debris before checking blower/fan rotation.

Stand clear of exhaust to avoid personal injury.

### **To reverse rotation, single-phase power supply:**

Follow manufacturer's instructions on the motor's nameplate.

### **To reverse rotation, three-phase power supply:**

Turn electrical power OFF at source and switch any two leads on the output-side of the fan-motor starter.

### **CAUTION**

Do not interchange a power lead with the ground wire. Severe damage or personal injury may result.

## Start-Up

1. Turn power ON at source.
2. Turn unit ON.
3. When airflow diminishes, turn the unit OFF and manually or automatically shake the filters.

## Maintenance Information

Instruct all personnel on safe use and maintenance procedures.



**WARNING** Electrical installation must be performed by a qualified electrician and comply with all applicable national and local codes.

Turn power off and lock out electrical power sources before performing service or maintenance work.

Do not install in classified hazardous atmospheres without an enclosure rated for the application.

### Operational Checklist

1. Monitor the physical condition of the collector and repair or replace any damaged components. Routine inspections will minimize downtime and maintain optimum system performance. This is particularly important on continuous-duty applications. Periodically check the compressed air components and replace compressed air filters. Drain moisture following the manufacturer's instructions. With the compressed air supply ON, check the cleaning valves, solenoid valves, and tubing for leaks. Replace as necessary.
2. Monitor pressure drop across filters.  
Abnormal changes in pressure drop indicate a change in operating conditions and possibly a fault to be corrected. For example, prolonged lack of compressed air will cause an excess build-up of dust on the filters resulting in increased pressure drop. Cleaning off-line with no flow usually restores the filters to normal pressure drop.
3. Monitor exhaust.
4. Monitor dust disposal.

### Dust Disposal



**CAUTION** Use proper safety and protective equipment when removing contaminants and filters.

Empty the dust drawer when it is 2/3 full. Remove dust that has settled to the bottom of the collector.

1. Turn power OFF.
2. Manually clean or allow the automatic filter shaker to clean the filters.
3. When the cleaning cycle is complete, open the filter access door.
4. Reach inside the opening, grasp the dust drawer edge, and pull the dust drawer out of the collector.
5. Dispose of properly.

### EZ Filter Maintenance



**CAUTION** Use proper safety and protective equipment when removing contaminants and filters.

Dirty filters may be heavier than they appear.

Use care when removing filters to avoid personal injury.

1. Manually or automatically clean the filters once each day depending on dust load circumstances.
2. A good practice is to clean filters at break, lunch, and end of day.
3. If the collected material begins to stick and accumulate on the filter surfaces, they may require manual cleaning.
4. Clean the sealing surface with damp cloth.

### NOTICE

Clean dust from gasket sealing area to ensure a positive filter gasket seal.

5. Check for an accumulation of dust in the storage area and empty as necessary.

## EZ Filter Pack Installation Instructions

### STEP 1

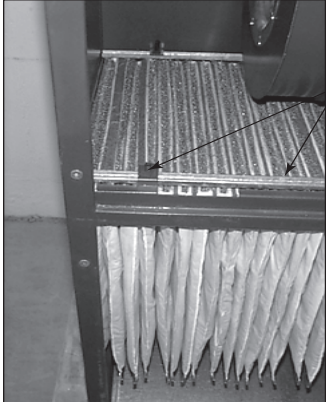

- Remove upper door and open lower door.
- Remove and discard set screws and hold-down channels.
- Remove old envelope bags.

### STEP 2



- Clean bottom of cabinet ledge with stiff brush.

#### **NOTICE**

The EZ Filter Pack seals against the bottom of the cabinet ledge.

- Remove and empty dust pan.

### STEP 3

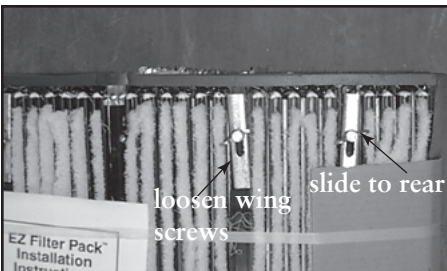

- Remove banded EZ Filter Pack from box. Do not remove bands.
- Fully loosen wing screws.
- Move slide latches to the rear—away from gasket.

### STEP 4



- Insert banded EZ Filter Pack over shaker bar.

### STEP 5



- Rest banded EZ Filter Pack on shaker bar.

### STEP 6



- Cut and remove bands.
- Remove cardboard protectors.

### STEP 7



- Insert one hand midway under each side of the EZ Filter Pack.
- Push EZ Filter Pack to bottom of cabinet filter frame.

### STEP 8 - IMPORTANT



- Place one hand under center of EZ Filter Pack.
- Hold EZ Filter Pack against bottom of cabinet ledge.
- Push each slide latch over cabinet ledge.
- Do not tighten wing screws at this time.

### STEP 9



- Adjust EZ Filter Pack for good fit.
- Finger tighten wing screws.

### STEP 10



- Remove support bar from box.

### STEP 11



- Place support bar over center of EZ Filter Pack.

### STEP 12



- Insert small wing screws through holes in support bar.
- Hand tighten all wing screws.

### STEP 13



- Inspect filter seal.
- Insert clean dust pan.
- Install and close doors.

## Optional Equipment

### Magnehelic® Gauge

The Magnehelic is a differential pressure gauge used to measure the pressure difference between the clean- and dirty-air chambers and provides a visual display of filter change requirements. The high-pressure tap is located in the dirty-air chamber and the low-pressure tap is located in the clean-air chamber.

1. Choose a convenient, accessible location on or near the unit for mounting that provides the best visual advantage.

If unit is equipped with factory-installed pressure taps, skip to Step 5.

2. Before drilling, place a piece of non-combustible cloth over the filter opening in the clean-air chamber to protect them from drilling chips.
3. Place a piece of wood behind the drill location in the dirty-air chamber to protect the filters from damage by the drill bit. Use a .406-inch diameter bit to drill the holes as shown in Magnehelic Gauge, Detail A.
4. Mount the pressure tap hardware on the clean-air chamber panel. Mount the pressure tap with the tee inside the dirty-air chamber.
5. Plug the pressure ports on the back of the gauge using two, 1/8-in NPT pipe plugs supplied. Install two, 1/8-in NPT male adapters supplied with the gauge into the high- and low-pressure ports on the side of the gauge. Attach the mounting bracket using three, #6-32 x 1/4-in screws supplied.

6. Mount the gauge and bracket assembly to the supporting structure using two self-drilling screws.
7. Thirty-five feet of plastic tubing is supplied and must be cut in two sections. Connect one section of tubing from the gauge's high-pressure port to the pressure fitting located in the dirty-air chamber. Connect remaining tubing from the gauge's low-pressure port to the fitting in the clean-air chamber. Additional tubing can be ordered from your representative.
8. Carefully remove the cloth protecting the filters. Close access door and tighten securely by hand.
9. Zero and maintain the gauge as directed in the manufacturer's Operating and Maintenance Instructions provided.

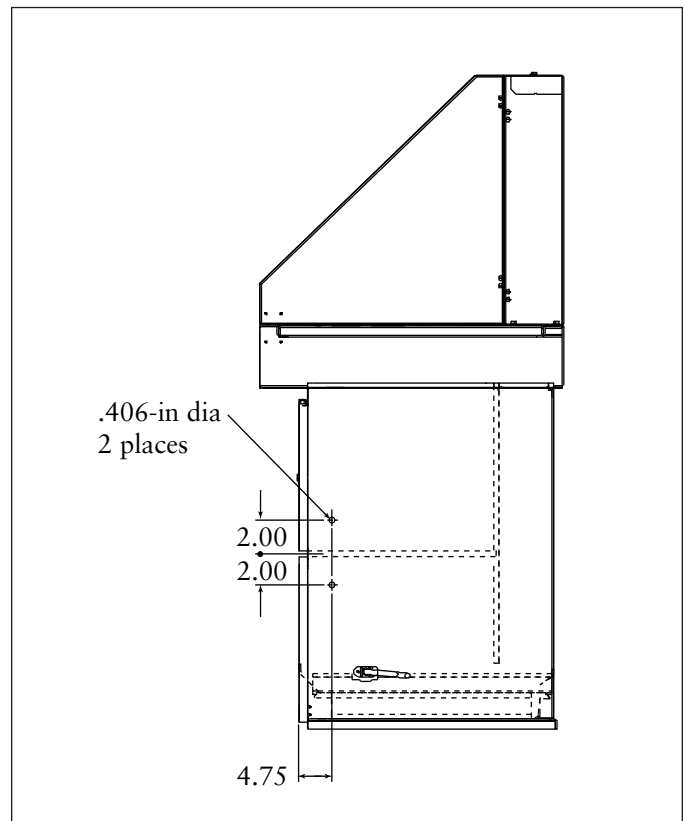

*Magnehelic Gauge Detail A*

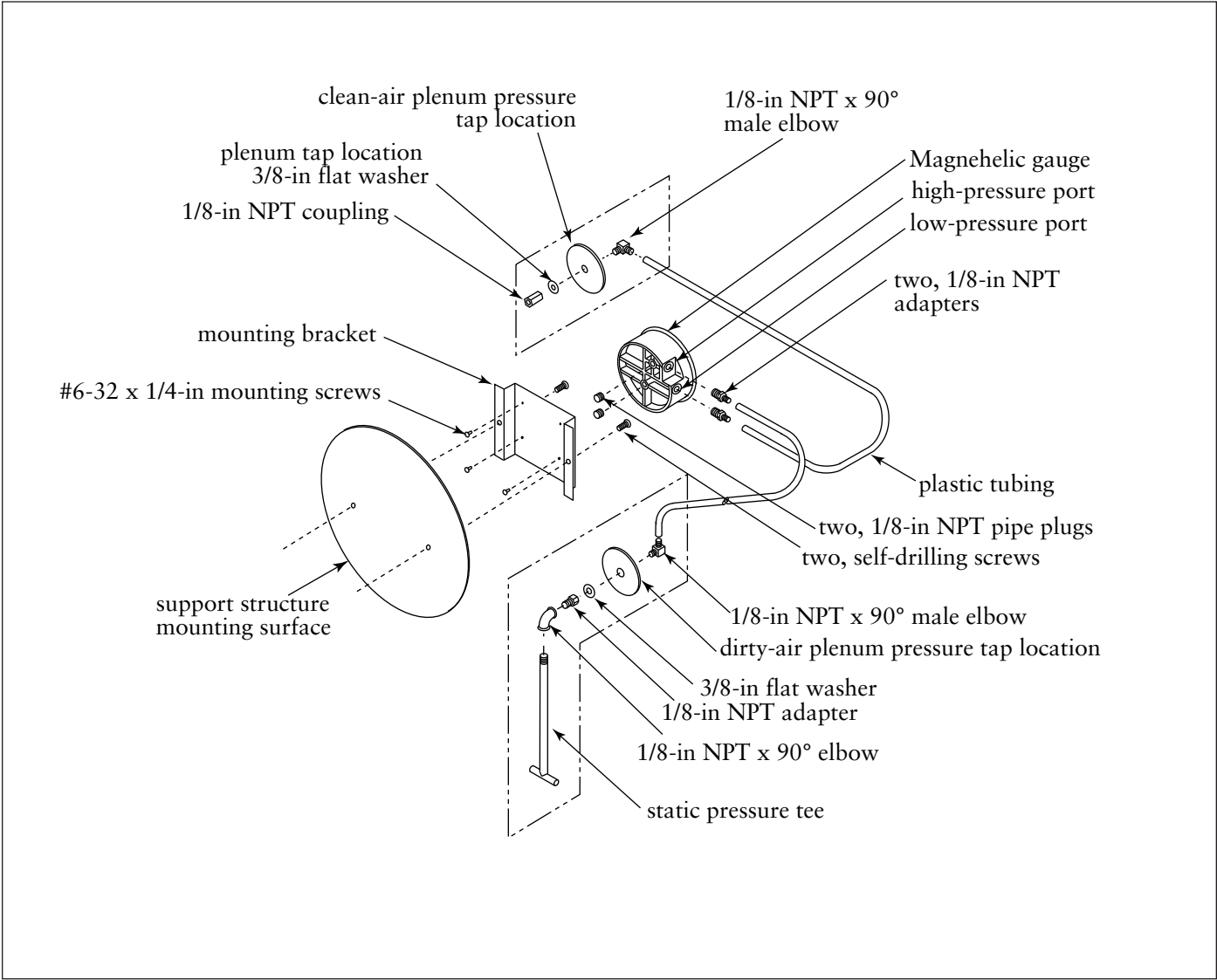

*Magnehelic Gauge Assembly*

## Work Surface Rubber Mat

An optional 5/8-inch thick nitrile-rubber mat is available for the Downdraft Bench. Used to protect the work piece during buffing or grinding operations, the mat is oil, grease, alkali and acid resistant, and suitable for aircraft components.

## Automatic Shaker

The automatic shaker is driven by a 1/10 Hp TENV gear motor controlled by a solid-state timer. The timer control box can be ordered with or without a step-down transformer. A timer control box without the transformer requires a 120-Volt AC power supply controlled by a customer-supplied fan starter. Input power is supplied to the timer on fan motor shutdown, through the normally closed auxiliary contact of the fan starter. After a 60-second delay, the timer energizes and the shaker motor starts for a 30-second fixed time. Turning the unit ON and OFF initiates the shaker sequence.



Electrical installation must be performed by a qualified electrician and comply with all applicable national and local codes.

Turn power off and lock out electrical power sources before performing service or maintenance work.

Do not install in classified hazardous atmospheres without an enclosure rated for the application.

1. Locate and mount the automatic shaker control box assembly. The control box can be located on the dust collector cabinet or next to the blower starter.
2. Complete the wiring to the customer-supplied blower starter, shaker control box, and shaker motor using the appropriate control box component layout and wiring diagram.

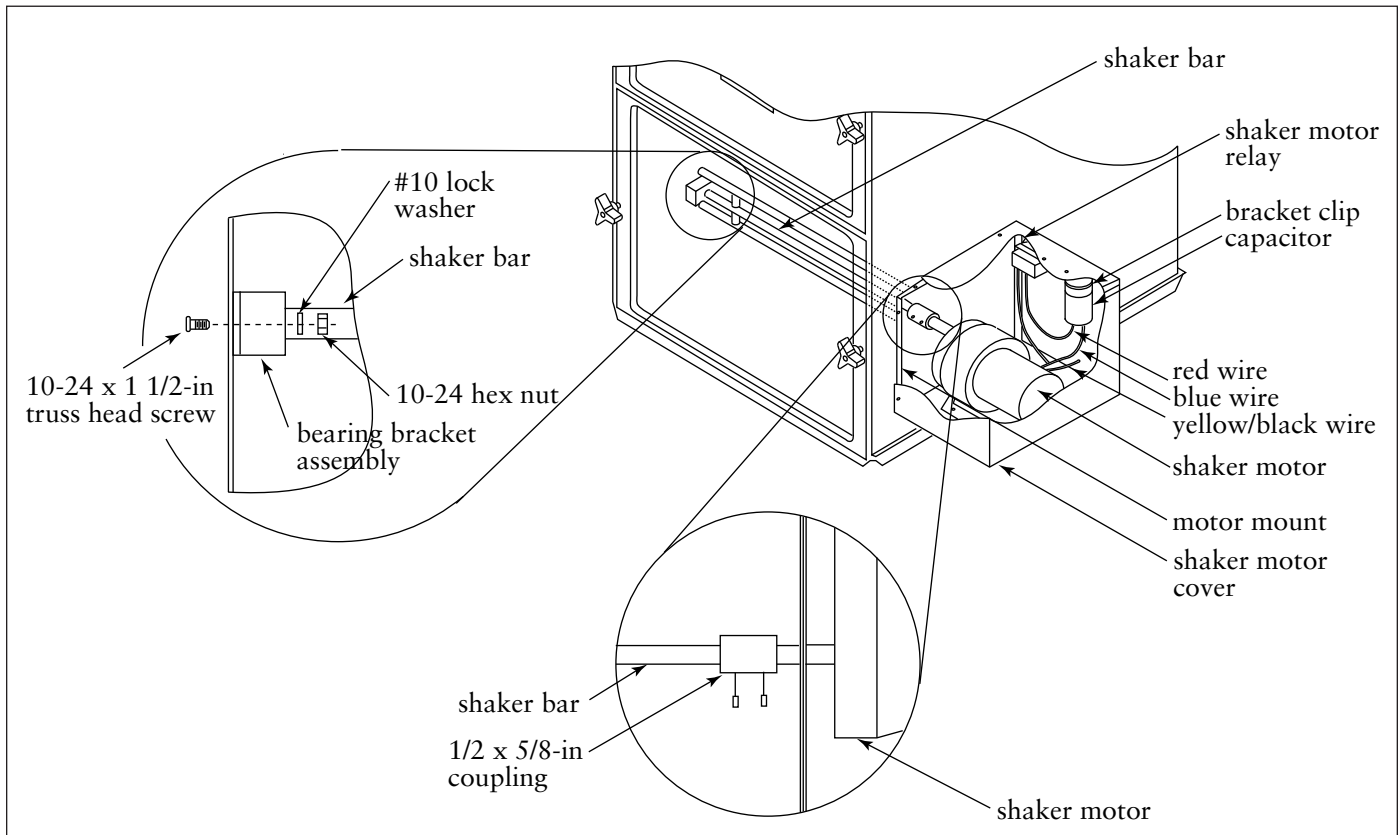

*Automatic Shaker Assembly*

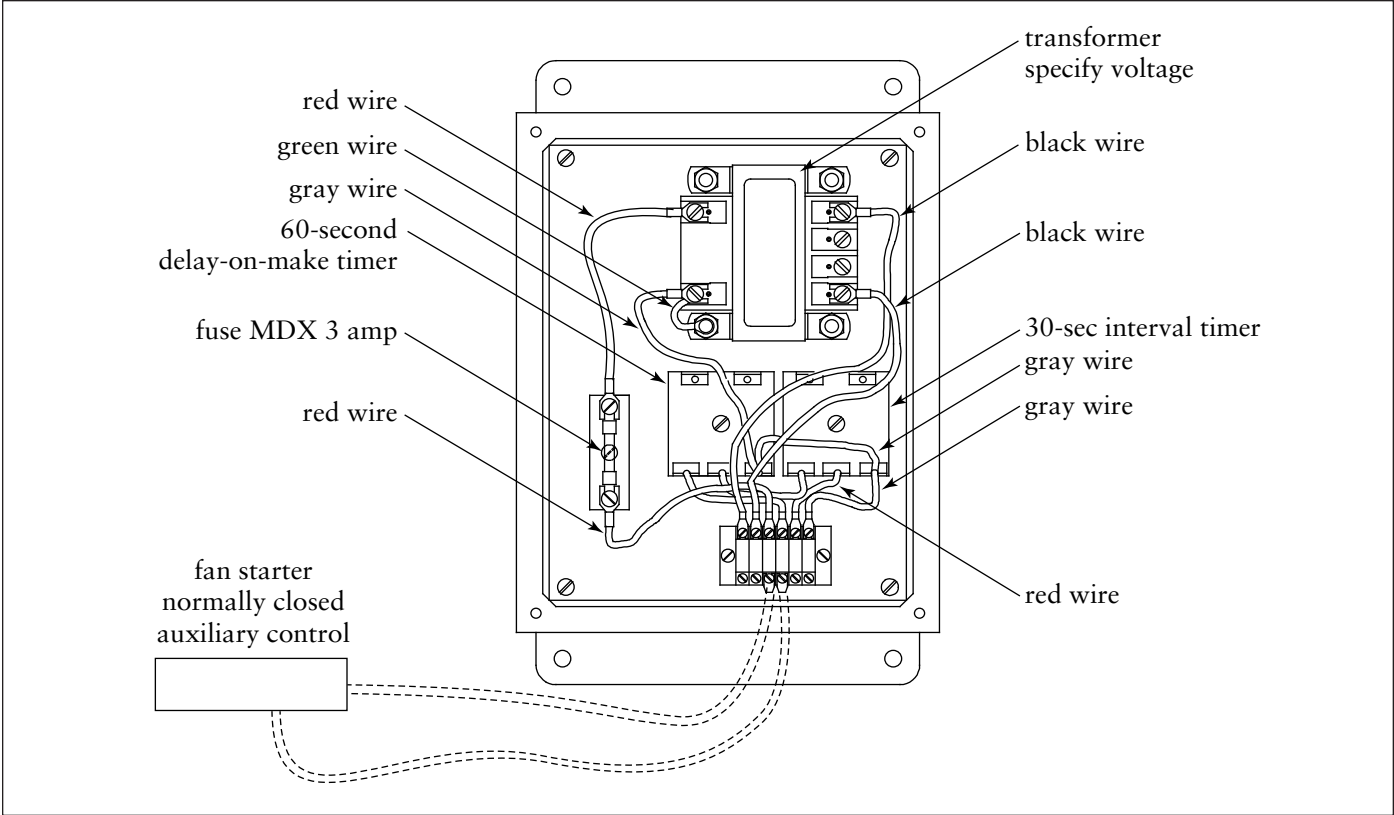

Automatic Shaker with Transformer

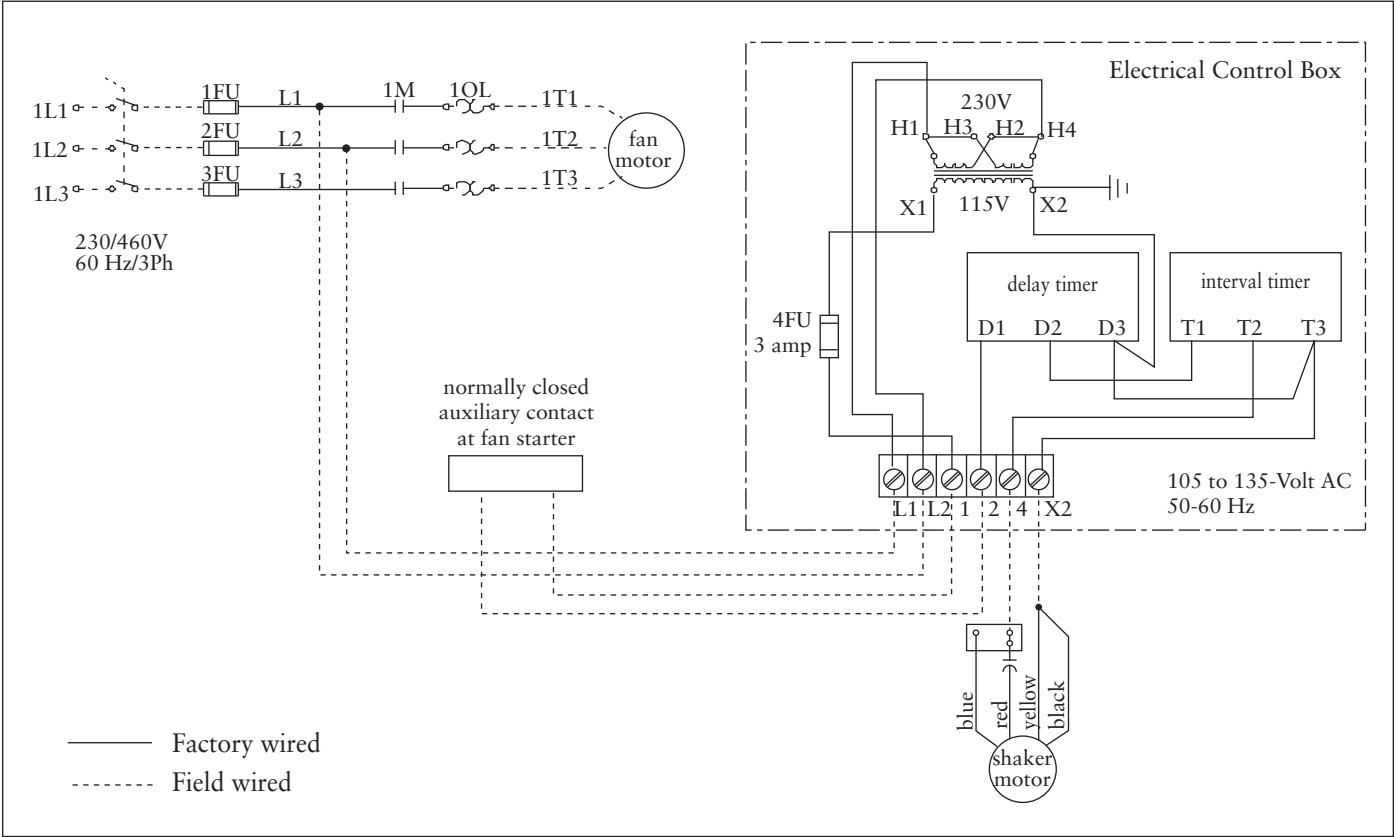

Automatic Shaker with Transformer Wiring Diagram

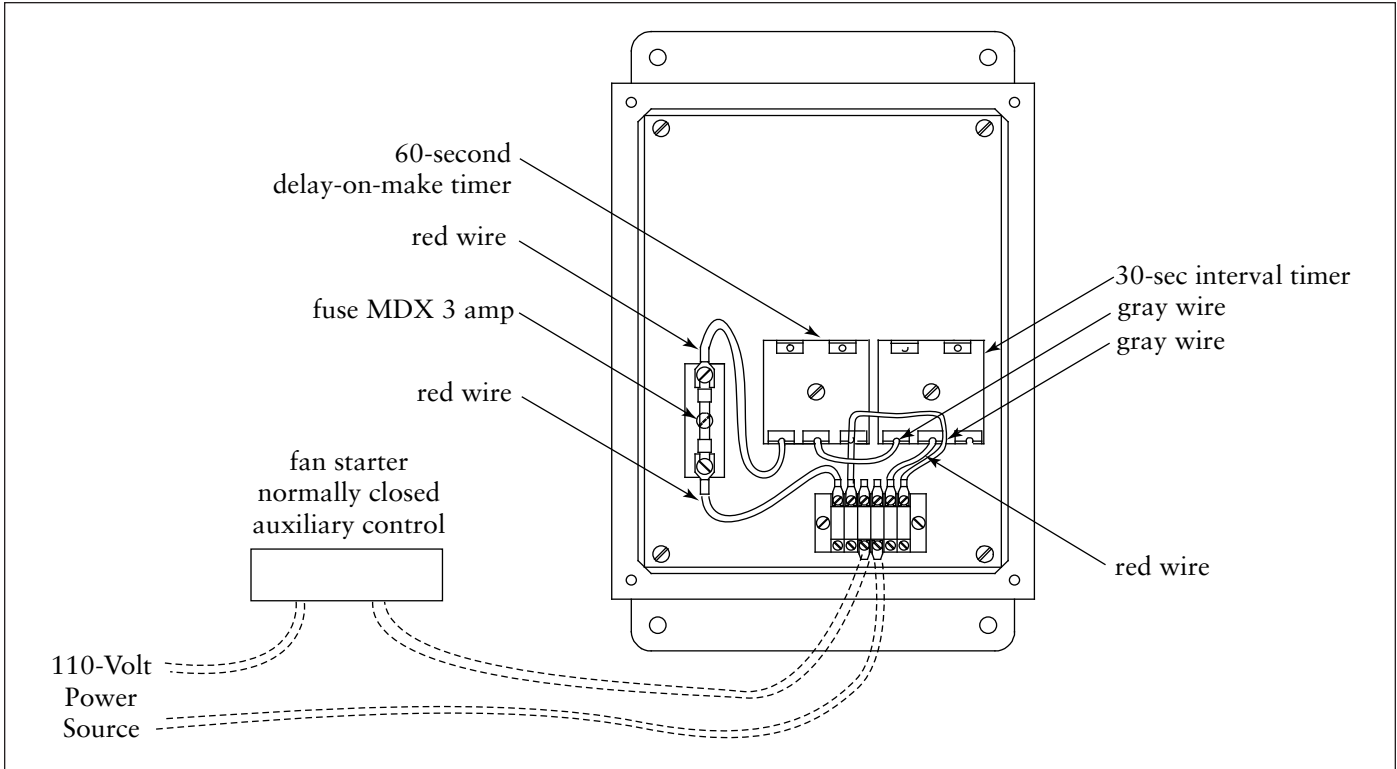

*Automatic Shaker without Transformer*

**NOTICE**

The automatic shaker requires a 120-Volt power supply controlled by the fan starter. The normally-closed auxiliary contact is supplied by others.

**Solid-State Timer Specifications**

**Sequence of Operation**

Input power is supplied to Terminals L1 and L2 of the automatic shaker control. On fan shutdown the normally-closed auxiliary contact closes and power is supplied to the solid-state timer which activates the delay-on-make timer. After 60-seconds, the delay-on-make timer energizes the interval timer and starts the shaker motor. After 30-sec, the interval timer times out and the shaker motor turns OFF.

Input: 105 to 135-Volt AC, 50-60 Hz

Output: 700 Watts maximum load

**Shaker Motor Specifications**

Input: 105 to 135-Volt AC, 50-60 Hz

Output: 2.6 amp maximum load

Rating: Intermittent load, 1-min/Hour

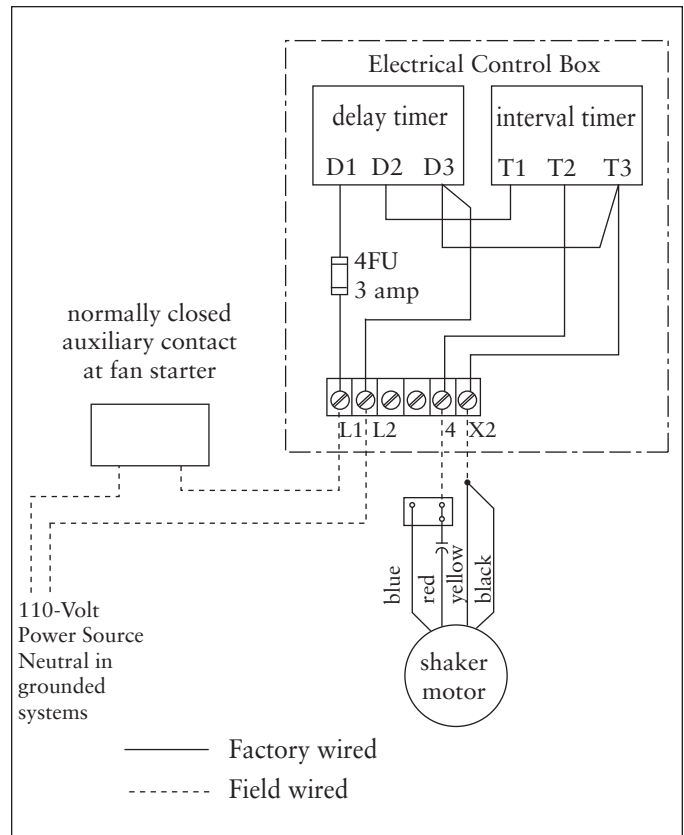

*Automatic Shaker without Transformer Wiring Diagram*

## Troubleshooting

<b>Problem</b>	<b>Probable Cause</b>	<b>Remedy</b>
<b>Blower fan and motor do not start</b>	Improper motor wire size	Rewire using the correct wire gauge as specified by national and local codes.
	Not wired correctly	Check and correct motor wiring for supply voltage. See motor manufacturer's wiring diagram. Follow wiring diagram and the National Electric Code.
	Unit not wired for available voltage	Correct wiring for proper supply voltage.
	Input circuit down	Check power supply to motor circuit on all leads.
	Electrical supply circuit down	Check power supply circuit for proper voltage. Check for fuse or circuit breaker fault. Replace as necessary.
<b>Blower fan and motor start, but do not stay running</b>	Incorrect starter overload installed	Check motor starter-overload range and replace if necessary.
	Access doors are open or not closed tight	Close and tighten access doors.
	Electrical circuit overload	Check that the power supply circuit has sufficient power to run all equipment.
<b>Insufficient airflow</b>	Fan rotation backwards	Proper fan rotation is clockwise from the top of the unit. The fan can be viewed through the back of the motor. See Preliminary Start-Up Check section.
	Access doors open or not closed tight	Check that all access doors are in place and secured.
	Filter plugged	Shake the EZ Filter Pack once per day. Brush fibrous or sticky material off filter bags, if necessary, replace EZ Filter Pack. See EZ Filter Pack Installation section.
	Dust storage area overfilled or plugged	Empty and replace the dust drawer when 2/3 full.

## Troubleshooting

Problem	Probable Cause	Remedy
Manual shaker mechanism not working	Hand or foot pedal broken	Replace hand or foot pedal and roll pin if necessary.
Automatic shaker mechanism not working	No input voltage to transformer	Check and correct voltage at transformer Terminals H1 and H4. See Automatic Shaker with Transformer Wiring Diagram.
	No output voltage from transformer	Using a voltmeter, check for input and output voltage at the transformer's fuse. If input voltage is present, but no output voltage, replace transformer fuse with identical fuse only.  Check and correct voltage at transformer Terminals X1 and X2. If 115-V is not present, replace the transformer.
	Delay-on-make timer failure	Check input voltage at Terminal D1 on the delay-on-make timer. Wait 60-seconds and check output voltage at Terminal D2. If input voltage is present, but no output voltage, replace the delay-on-make timer.
	Interval timer failure	Wait for the 60-second delay and check for input voltage at Terminal T1 on the interval timer. If input voltage is present, check output voltage at Terminal T2 on the shaker motor. Replace interval timer if no output voltage is present.
	Shaker motor relay failure	Wait for the 60-second delay and check for input voltage at Terminal 4 of the motor relay located under the shaker cover. Check output voltage at Terminal 2. If no output voltage is present, replace the shaker motor relay.
	Capacitor failure	Wait for the 60-second delay and check for input voltage at the capacitor's input terminals. Check for output voltage at the capacitor's output terminal. If input voltage is present, but no output voltage, replace the capacitor.
	Shaker arm restricted	Disconnect the shaker bar and check the nylon link and bearing. It should pivot in the shaker channel easily. With the shaker bar disconnected, allow the shaker motor to run and check the amp draw. If over 2.5 amps, replace the shaker motor.
	Shaker motor failure	Check all input circuits to the shaker motor. If all terminals and components are okay but shaker motor does not start, replace the shaker motor.

<b>Problem</b>	<b>Probable Cause</b>	<b>Remedy</b>
<b>Shaker motor runs, but EZ Filter Pack not being cleaned</b>	Damaged shaker bar coupling	Check the coupling that connects the shaker bar and the shaker motor. Tighten the setscrews to the shaft flats.
	Shaker arm restricted	<p>Check for and remove debris from the shaker arm. Check that the EZ Filter Pack is not lodged between the cabinet wall and shaker bar. See EZ Filter Pack Installation section.</p> <p>Disconnect the shaker bar and check the nylon link and bearing. It should pivot in the shaker channel easily. With the shaker bar disconnected, allow the shaker motor to run and check the amp draw. If over 2.5 amps, replace the shaker motor.</p>
	Shaker bar not gapped properly	Loosen the setscrews in the coupling that joins the shaker bar and the shaker motor. Adjust the gap between the shaker bar and the cabinet walls equally. Tighten setscrews.
<b>Shaker motor blows fuse</b>	Shaker arm restricted	Check for and remove debris from the shaker arm. Check that the EZ Filter Pack is not lodged between the cabinet wall and shaker bar. See EZ Filter Pack Installation section.





## The Donaldson Torit Warranty

Donaldson warrants to the original purchaser that the major structural components of the goods will be free from defects in materials and workmanship for ten (10) years from the date of shipment, if properly installed, maintained and operated under normal conditions. Donaldson warrants all other Donaldson built components and accessories including Donaldson Airlocks, TBI Fans, TRB Fans, Fume Collector products, Donaldson built electrical control components and Donaldson built Afterfilter housings for twelve (12) months from date of shipment. Donaldson warrants Donaldson built filter elements to be free from defects in materials and workmanship for eighteen (18) months from date of shipment. Donaldson does not warrant against damages due to corrosion, abrasion, normal wear and tear, product modification, or product misapplication. Donaldson also makes no warranty whatsoever as to any goods manufactured or supplied by others including electric motors, fans and control components. After Donaldson has been given adequate opportunity to remedy any defects in material or workmanship, Donaldson retains the sole option to accept return of the goods, with freight paid by the purchaser, and to refund the purchase price for the goods after confirming the goods are returned undamaged and in usable condition. Such a refund will be in the full extent of Donaldson's liability. Donaldson shall not be liable for any other costs, expenses or damages whether direct, indirect, special, incidental, consequential or otherwise. The terms of this warranty may be modified only by a special warranty document signed by a Director, General Manager or Vice President of Donaldson. Failure to use genuine Donaldson replacement parts may void this warranty. **THERE EXIST NO OTHER REPRESENTATIONS, WARRANTIES OR GUARANTEES EXCEPT AS STATED IN THIS PARAGRAPH AND ALL OTHER WARRANTIES INCLUDING MERCHANTABILITY AND FITNESS FOR A PARTICULAR PURPOSE, WHETHER EXPRESS OR IMPLIED ARE HEREBY EXPRESSLY EXCLUDED AND DISCLAIMED.**

### Parts and Service

For genuine Donaldson Torit replacement filters  
and parts, call the Parts Express Line

**800-365-1331 USA**

**800-343-3639 Mexico**

**[www.donaldsontorit.com](http://www.donaldsontorit.com)**

For faster service, have unit's model and serial number,  
part number, description, and quantity available.



**Donaldson**

*Filtration Solutions*

Donaldson Company, Inc.  
Industrial Air Filtration  
P.O. Box 1299  
Minneapolis, MN 55440-1299  
[donaldsontorit@donaldson.com](mailto:donaldsontorit@donaldson.com)

Donaldson Company, Inc. is the leading designer and manufacturer of dust, mist, and fume collection equipment used to control industrial-air pollutants. Our equipment is designed to help reduce occupational hazards, lengthen machine life, reduce in-plant maintenance requirements, and improve product quality.