



Dalamatic® Insertable

DLMV

Installation and Operation Manual

Installation, Operation, and Service Information

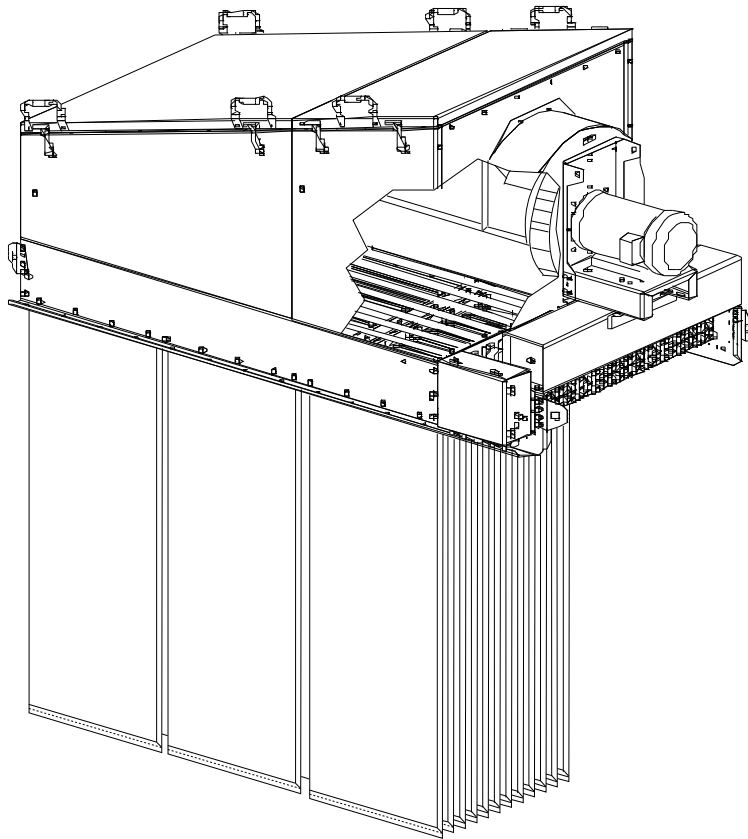

This manual is property of the owner. Leave with the unit when set-up and start-up are complete. Donaldson Company reserves the right to change design and specifications without prior notice.

Illustrations are for reference only as actual product may vary.



This is the safety alert symbol. It is used to alert you to potential personal injury hazards. Obey all safety messages that follow this symbol to avoid possible injury or death.



APPLICATION OF DUST CONTROL EQUIPMENT

Combustible materials such as buffing lint, paper, wood, metal dusts, weld fume, or flammable coolants or solvents represent potential fire and/or explosion hazards. Use special care when selecting, installing, and operating all dust, fume, or mist collection equipment when such combustible materials may be present in order to protect workers and property from serious injury or damage due to a fire and/or explosion.

Consult and comply with all National and Local Codes related to fire and/or explosion properties of combustible materials when determining the location and operation of all dust, fume, or mist collection equipment.

When combustible materials are present you must consult with an expert in fire extinguishing and/or explosion protection systems, who is also familiar with the local codes, for support and guidance on the selection and installation of an appropriate fire and/or explosion protection system.

DO NOT allow sparks, cigarettes or other burning objects to enter the hood or duct of any dust, fume, or mist collection equipment as these may initiate a fire or explosion of any combustible materials accumulated in the collector.

Portions of dust, mist, and fume-collection equipment, including the clean- and dirty-air plenums may be considered "OSHA Confined Spaces." Refer to the appropriate OSHA regulations to determine if a specific installation should be considered a confined space and if a permit program is required.

Recirculating filtered air in your facility can be a hazard. Consult with OSHA to ensure compliance with all codes regarding recirculating filtered air.

Improper operation of a dust, fume, or mist control system may contribute to conditions in the work area or facility that could result in severe personal injury and product or property damage. Check that all dust, fume, or mist collection equipment is properly selected, installed, and operated for its intended use.

This manual contains specific precautionary statements relative to worker safety. Read this manual thoroughly and comply as directed. Instruct all personnel on the safe use and maintenance procedures related to this equipment. Discuss any questions on the application, use, or maintenance of this equipment with a Donaldson Torit representative.

For optimum collector performance, use only Donaldson Torit replacement parts.

Data Sheet

Model Number _____	Serial Number _____
Ship Date _____	Installation Date _____
Customer Name _____	
Address _____	

Filter Type _____	
Accessories _____	
Other _____	

Contents

Description.....	1	Maintenance Information.....	13
Purpose and Intended Use.....	1	Operational Checklist	13
Rating and Specification Information.....	2	Diaphragm Replacement	14
Operation.....	3	Filter Bag Replacement.....	14
Inspection on Arrival.....	4	Compressed Air Components.....	15
Installation Codes and Procedures	4	Optional Equipment.....	16
Installation.....	4	Magnehelic® Gauge	16
Site Selection.....	4	Photohelic® Gauge	17
Unit Location	4	Delta P Control	19
Rigging Instructions.....	5	Delta P Plus Control	20
Hoisting Information	5	Antistatic Option.....	21
Typical Installation.....	6	Explosion Relief Vents	22
Standard Equipment.....	7	Troubleshooting.....	23
Unit Installation.....	7		
Filter Bag Installation.....	7		
Solid-State Timer Installation.....	9		
Solenoid Connection.....	9		
Timer and Solenoid Specifications.....	9		
Compressed Air Installation	11		
Preliminary Start-Up.....	12		
Start-Up.....	12		
Shut Down	12		

Magnehelic® and Photohelic® are registered trademarks of Dwyer Instruments, Inc.



DANGER indicates a hazardous situation which, if not avoided, will result in death or serious injury.



WARNING indicates a hazardous situation which, if not avoided, could result in death or serious injury.



CAUTION, used with the safety alert symbol, indicates a hazardous situation which, if not avoided, could result in minor or moderate injury.



NOTICE is used to address practices not related to personal injury that may result in damage to equipment.

Description

The Dalamatric Model DLMV Insertable dust collectors are continuous-duty collectors with bag-style filters designed to handle known quantities of dust. Primarily installed in storage vessels or silos, they provide continuous filtration and maintain high collection efficiency at constant system resistance. Variations are available for pneumatic conveying operations where high dust concentrations of raw materials and particulate products are found. Continuous duty means no downtime. The filters are pulse-cleaned one at a time without turning the unit off. Standard sizes range from 43 to 645 sq ft of filter area and feature either a Delta P or DeltaP Plus controller to control the filter cleaning operation.

Purpose and Intended Use



Misuse or modification of this equipment may result in personal injury.

Do not misuse or modify.

In pneumatic conveying systems, Dalamatric Insertables can be inserted through the top of silos or storage vessels to separate the product conveying from displaced air to prevent product loss and nuisance dust. DLMV, Type B and W are suitable for positive pressure systems and Type F and H are applied when a suction fan is required to overcome negative system pressure. In mechanical conveying systems, the dust generated by product loading, transfer, and discharge can be controlled using a DLMV, Type F in an enclosure. The collected dust returns directly to the product conveyed making expensive ductwork systems unnecessary, saving space, and eliminating dust disposal issues.

Dalamatric Insertables can be integrated with process machinery requiring dust control such as fluid bed reactors, mixers, blenders, mills, and crushers. Some typical applications include powder paint booths and automatic bag-slitting machines. The DLMV is commonly used in the chemical, mineral, food, plastic, asbestos, metal compounds, and pharmaceutical industries. With custom modifications, the DLMV is suitable for high-temperature applications.



Combustible materials such as buffing lint, paper, wood, metal dusts, weld fume, or flammable coolants or solvents represent potential fire and/or explosion hazards. Use special care when selecting, installing, and operating all dust, fume, or mist collection equipment when such combustible materials may be present in order to protect workers and property from serious injury or damage due to a fire and/or explosion.

Consult and comply with all National and Local Codes related to fire and/or explosion properties of combustible materials when determining the location and operation of all dust, fume, or mist collection equipment.

Standard Donaldson Torit equipment is not equipped with fire extinguishing or explosion protection systems.

Rating and Specification Information

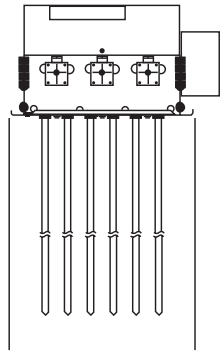

Front View
DLMV B

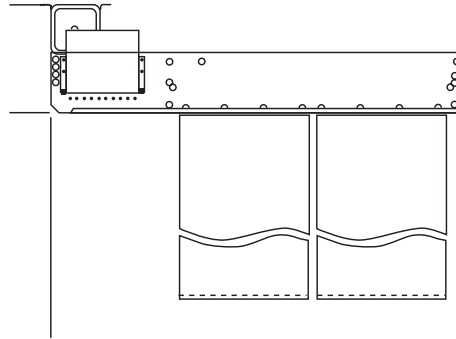

Typical Side View
DLMV B

All Units:

Compressed air, maximum psig 65-90
 Housing rating, inches water gauge +/- 20
 Power and controls 120-Volt 50/60 Hz

*If unit was supplied with a Record Drawing, the specifications on the drawing will supersede the standard specifications above.

Operation

During normal operation, dust-laden air is drawn to the filter bags. The velocity is reduced and natural pre-separation, caused by the effects of gravity, takes place. Fine particles collect on the outside surface of the filter bag and clean, filtered air passes to the center of the bag and discharges through the clean-air outlet.

Filter cleaning is completed using pulse-jet technology. A jet tube positioned over each filter bag distributes a pulse of compressed air through the filter. As the compressed air enters the filter bag, airflow is temporarily reversed and the bag inflates dislodging the dust cake formed on the outside of the bag. The bag deflates and the dust cake falls back into the silo or process equipment.

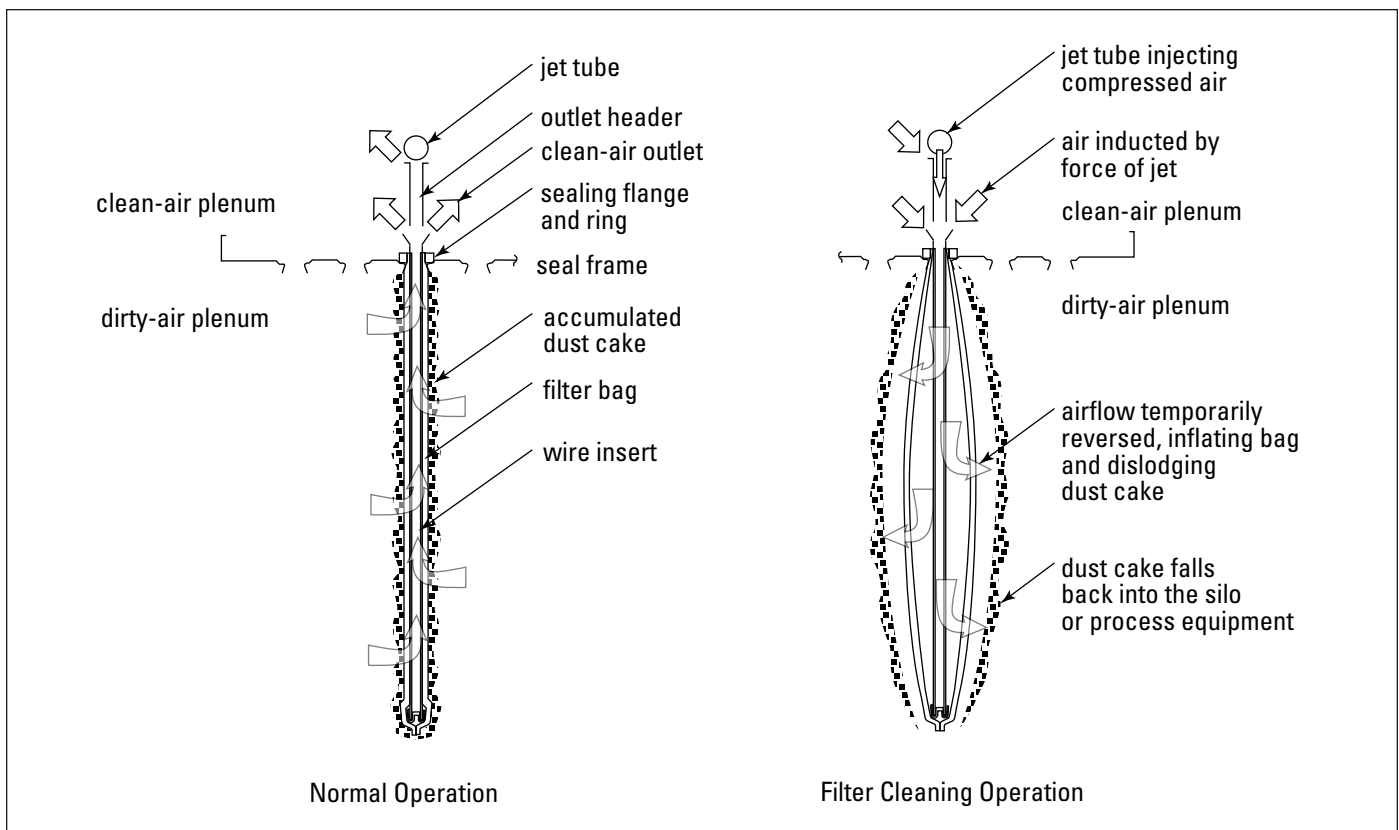

Unit Operation

Inspection on Arrival

1. Inspect unit on delivery.
2. Report any damage to the delivery carrier.
3. Request a written inspection report from the Claims Inspector to substantiate any damage claim.
4. File claims with the delivery carrier.
5. Compare unit received with description of product ordered.
6. Report incomplete shipments to the delivery carrier and your Donaldson Torit representative.
7. Remove crates and shipping straps. Remove loose components and accessory packages before lifting unit from truck.
8. Check for hardware that may have loosened during shipping.
9. Use caution removing temporary covers.

Installation Codes and Procedures



Codes may regulate recirculating filtered air in your facility.

Consult with the appropriate authorities having jurisdiction to ensure compliance with all national and local codes regarding recirculating filtered air.

Safe and efficient operation of the unit depends on proper installation.

Authorities with jurisdiction should be consulted before installing to verify local codes and installation procedures. In the absence of such codes, install unit according to the National Electric Code, NFPA No. 70-latest edition and NFPA 91 (NFPA 654 if combustible dust is present).

A qualified installation and service agent must complete installation and service of this equipment.

All shipping materials, including shipping covers, must be removed from the unit prior to, or during unit installation.

NOTICE

Failure to remove shipping materials from the unit will compromise unit performance.

Inspect unit to ensure all hardware is properly installed and tight prior to operating collector.

Installation



Site selection must account for wind, seismic zone, and other live-load conditions when selecting the location for all units.

Codes may regulate acceptable locations for installing dust collectors. Consult with the appropriate authorities having jurisdiction to ensure compliance with all national and local codes regarding dust collector installation.

Site Selection

The unit can be located in the top of storage silos and bins, or integrated into hoods for material handling equipment such as belt conveyors and bucket elevators or process equipment such as blenders and crushers.

Provide appropriate clearance from heat sources and interference with utilities.

Unit Location



Donaldson Torit equipment is not designed to support site-installed ducts, interconnecting piping, or electrical services. All ducts, piping, or electrical services supplied by others must be adequately supported to prevent severe personal injury and/or property damage.

When hazardous conditions or materials are present, consult with local authorities for the proper location of the collector

Foundation must be capable of supporting the entire weight of the unit, plus the weight of the collected material, piping, and ductwork.

Prepare the foundation in the selected location. Install anchor bolts a minimum of 1 3/4-inches above foundation.

Locate the collector to ensure easy access to electrical and compressed-air connections and routine maintenance.

Rigging Instructions

Suggested Tools & Equipment

Clevis Pins and Clamps	Lifting Slings
Crane or Forklift	Pipe Sealant
Drift Pins	Pipe Wrenches
Drill and Drill Bits	Screwdrivers
End Wrenches	Socket Wrenches
Adjustable Wrench	Spreader Bars
Torque Wrench (inch/lbs, 9/16-in Socket)	

Hoisting Information



Failure to lift the collector correctly can result in severe personal injury or property damage.

Use appropriate lifting equipment and adopt all safety precautions needed for moving and handling the equipment.

A crane or forklift is recommended for unloading, assembly, and installation of the collector.

Location must be clear of all obstructions, such as utility lines or roof overhang.

Use all lifting points provided.

Use clevis connectors, not hooks, on lifting slings.

Use spreader bars to prevent damage to unit's casing.

Check the Specification Control drawing for weight and dimensions of the unit and components to ensure adequate crane capacity.

Allow only qualified crane operators to lift the equipment.

Refer to applicable OSHA regulations and local codes when using cranes, forklifts, and other lifting equipment.

Lift unit and accessories separately and assemble after unit is in place.

Use drift pins to align holes during assembly.

Electrical Wiring



Electrical service or maintenance work must be performed by a qualified electrician and comply with all applicable national and local codes.

Turn power off and lock out electrical power sources before performing service or maintenance work.

Do not install in classified hazardous atmospheres without an enclosure rated for the application.

All electrical wiring and connections, including electrical grounding, should be made in accordance with the National Electric Code (NFPA No. 70-latest edition).

Check local ordinances for additional requirements that apply.

The appropriate wiring schematic and electrical rating must be used. See unit's rating plate for required voltage.

If the unit is not furnished with a factory-mounted disconnect, an electric disconnect switch having adequate amp capacity shall be installed in accordance with Part IX, Article 430 of the National Electrical Code (NFPA No. 70-latest edition). Check unit's rating plate for voltage and amperage ratings.

Refer to the wiring diagram for the number of wires required for main power wiring and remote wiring.

Typical Installation

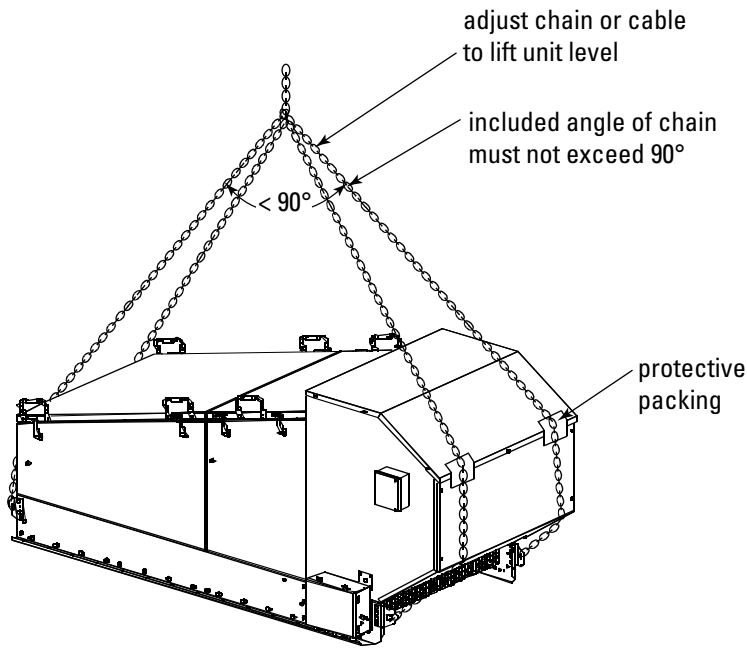

Four-Point Lift for Vertical Installation

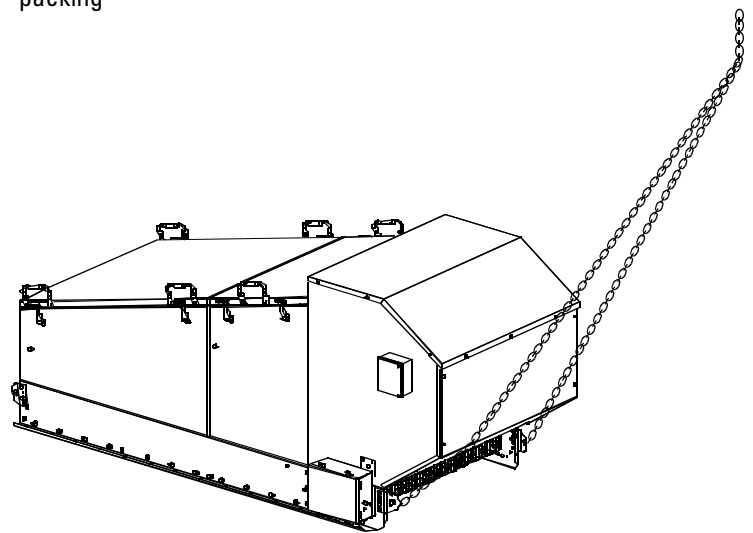

Two-Point Lift for Horizontal Installation, Manifold Up

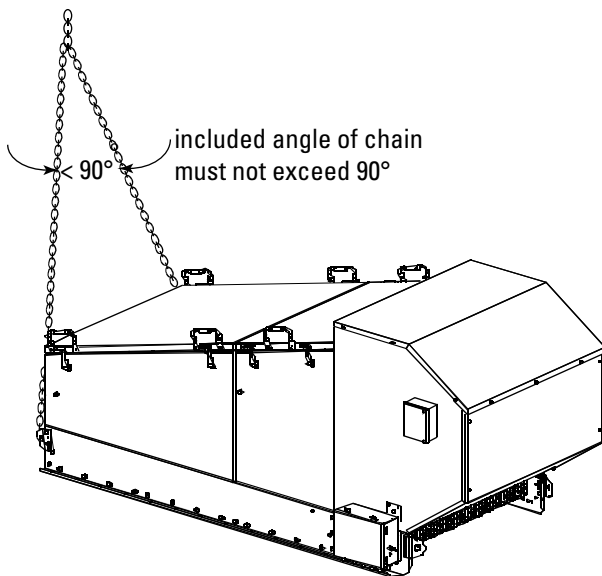

Two-Point Lift for Horizontal Installation, Manifold Down

Note: Horizontal installations are normally placed manifold up for service and maintenance access. However, if headroom is restricted, they may be placed manifold down.

Typical Installation

Standard Equipment

Dalamatic Insertable dust collectors are delivered partially assembled. Unit installation, filter bag installation, compressed air, and electrical connections are completed at the job site.

Unit Installation

Note: Compare the position and spacing of the bolt pattern on the unit's mounting flange to the bolt pattern on the mounting surface.

1. Open the header cover and remove the components shipped loose inside.
2. Apply two strips of 1/4-in diameter rope-type sealant or caulk to the mounting surface: one toward the inside of the bolt pattern and one toward the outside of the bolt pattern.

3. Lift unit into position over mounting surface and lower slowly.
4. Use drift pins to align holes.

Note: Install flat bar stiffeners, if equipped. See Optional Flat Bar Stiffener Installation.

5. Secure with bolts, washers, and hex nuts supplied. Tighten to form an airtight seal.

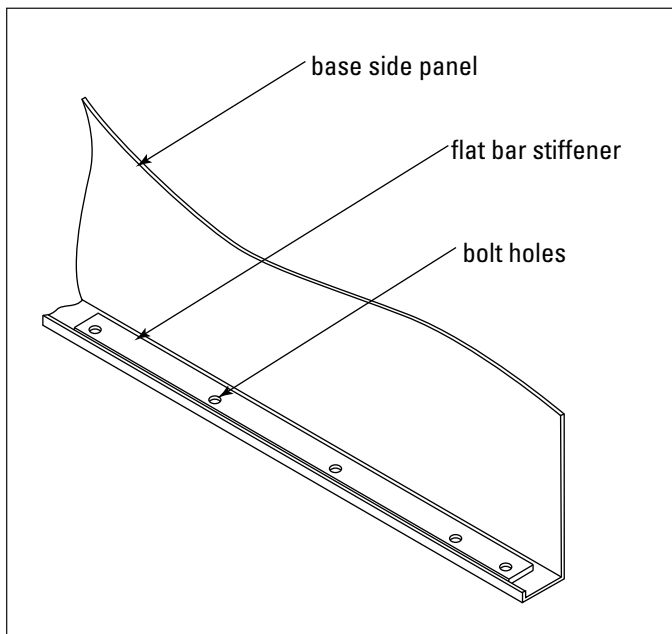

Optional Flat Bar Stiffener Installation

Filter Bag Installation

1. Remove header cover, if equipped.
2. Remove jet tubes and set aside.
3. Slide the filter bag over the wire support frame as shown. Slide bag carefully until top of bag is tight against the support frame flange.
4. Place filter bag and wire support assembly in seal frame slots as shown.
5. Position clamps and tighten using a deep well socket and extension. Do not overtighten. Maximum recommended torque is 20 ft/lb.

Note: If filter bags are mounted horizontally, tighten bottom clamp first.

6. Repeat to install all bags.
7. Replace jet tubes with the open end pressed firmly into its locator and the orifices directed toward the filter bag.

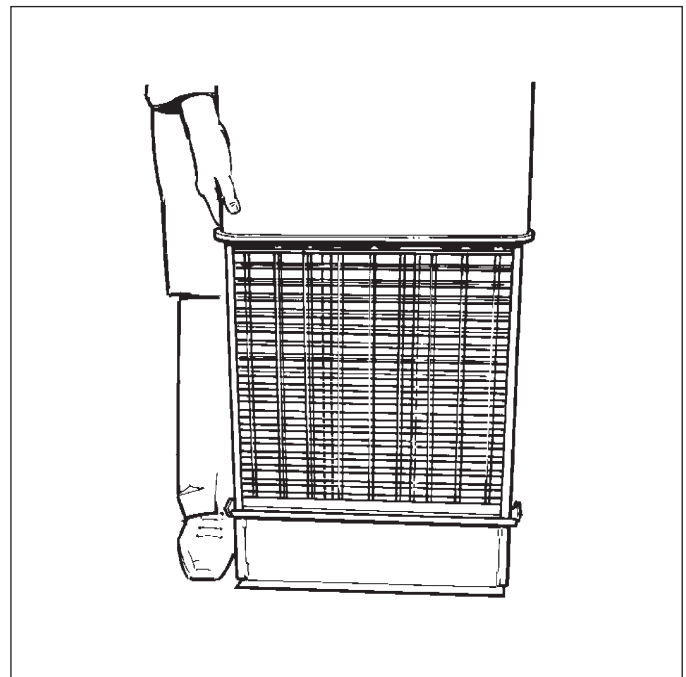

Filter Bag Assembly

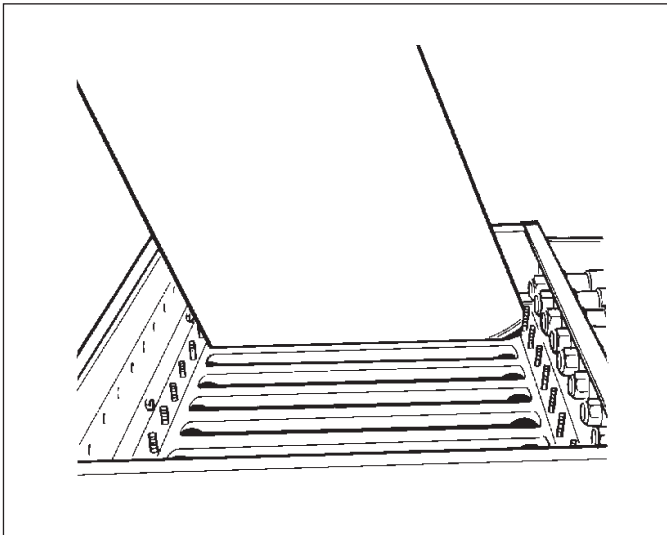

Filter Bag Installation

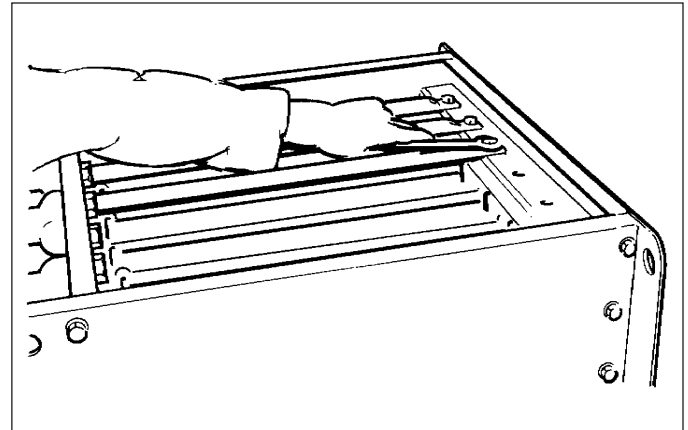

Jet Tube Installation

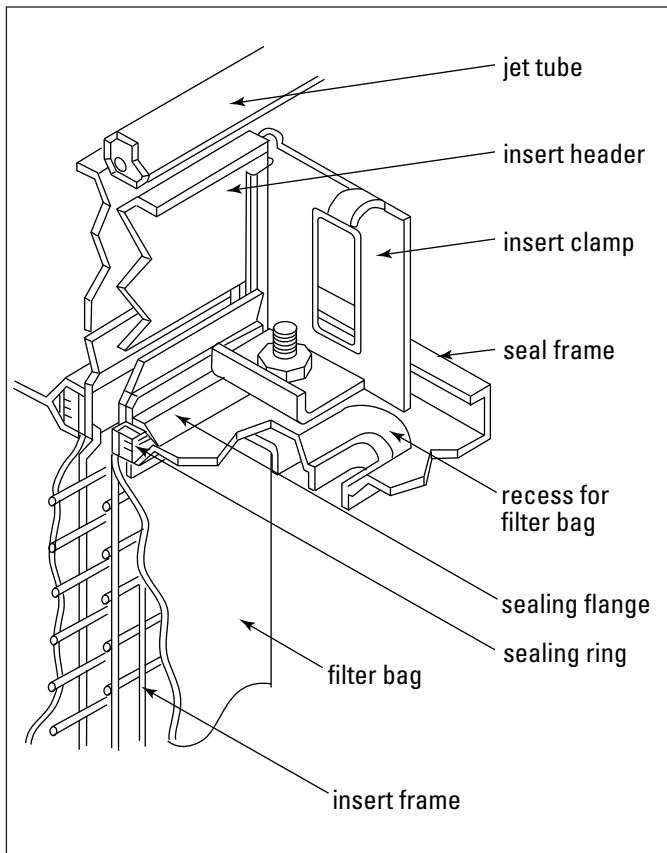

Filter Bag Detail

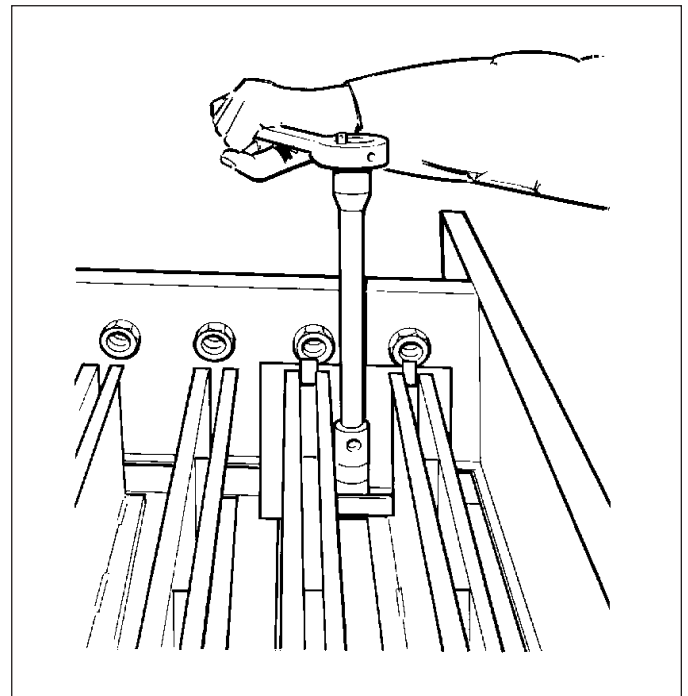

Clamps and Inserts

Solid-State Timer Installation

⚠ WARNING

Electrical work during installation must be performed by a qualified

electrician and comply with all applicable national and local codes.

Turn power off and lock out electrical power sources before performing installation, service, or maintenance work.

Do not install in classified hazardous atmospheres without an enclosure rated for the application.

The solid-state timer is an electronic timer used to control the filter cleaning system. Available options include 3, 6, 10, 20, and 32-pin solenoid valve control.

1. Using the wiring diagram supplied, wire the fan motor, fan-motor starter, solid-state timer, and solenoid valves. Use appropriate wire gauge for rated amp load as specified by local codes.
2. Plug the program lug into the pin that corresponds with the number of solenoid valves controlled.
3. With power supply ON, check the operation of the solenoid valves. The valves should open and close sequentially at factory set 10-second intervals.
4. If a Photohelic gauge or similar device is used to control the solid-state timer and the jumper on the pressure switch portion of the timer is removed, the solenoid valves pulse only when the differential pressure reaches the high-pressure setpoint. The valves continue to pulse until the low-pressure setpoint is reached.

NOTICE

The solid-state timer voltage must match the voltage of the rating of the timer provided (typically 115 VAC).

Do not mount the solid-state timer directly to the unit. Mechanical vibration can damage the control.

Solenoid Connection

The unit is equipped with solenoid valves (typically 115V) that control the pulse-cleaning valves, which clean the filters.

One of three types of solenoid enclosures, the weatherproof NEMA 4 with 3D2 solenoids, the explosion proof NEMA 7 with 5D2 solenoids, or the explosion proof NEMA 9 with 5D2 solenoids, is mounted near or on the unit's compressed-air manifold.

Wire the solenoids to the solid-state timer following the wiring diagram supplied with the unit. Filter life and cleaning operation will be affected if not wired correctly.

Timer and Solenoid Specifications

Power to the solid-state timer is supplied to Terminals L1 and L2, which must operate in parallel with the fan starter's low-voltage coil. On fan start-up, power is supplied to the timer and the preset OFF time is initiated. At the end of the OFF time, the timer energizes the corresponding solenoid valve to provide the ON time cleaning pulse for one diaphragm valve and then steps to the next until all filters have been cleaned.

To pulse when the fan is OFF, install a toggle switch as shown on the Solid-State Timer Wiring Diagram. When the toggle switch is ON, the timer receives power and energizes the solenoid valves' pulse-cleaning operation even though the fan is turned OFF.

Input
105-135V/50-60Hz/1Ph

Output Solenoids
The load is carried and turned ON and OFF by the 200 watt maximum-load-per-output solid-state switch.

Pulse ON Time
Factory set at 100-milliseconds, or 1/10-second.

NOTICE

Do not adjust pulse ON time unless the proper test equipment is available. Too much or too little ON time can cause shortened filter life.

Pulse OFF Time
Factory set at 10-seconds, adjustable from 1.5-sec minimum to maximum 30-seconds.

Operating Temperature Range
-20° F to 130° F

Transient Voltage Protection
50 kW transient volts for 20-millisecond duration once every 20 seconds, 1% duty cycle.

Solenoid Valves
115-Volt at 19.7 watts each

Compressed-Air
Set compressed-air supply for setting in Compressed Air Requirements table. The timer is factory set to clean one filter or set of filters every 10-seconds.

NOTICE

Do not increase supply pressure above 100-psig. Component damage can occur.

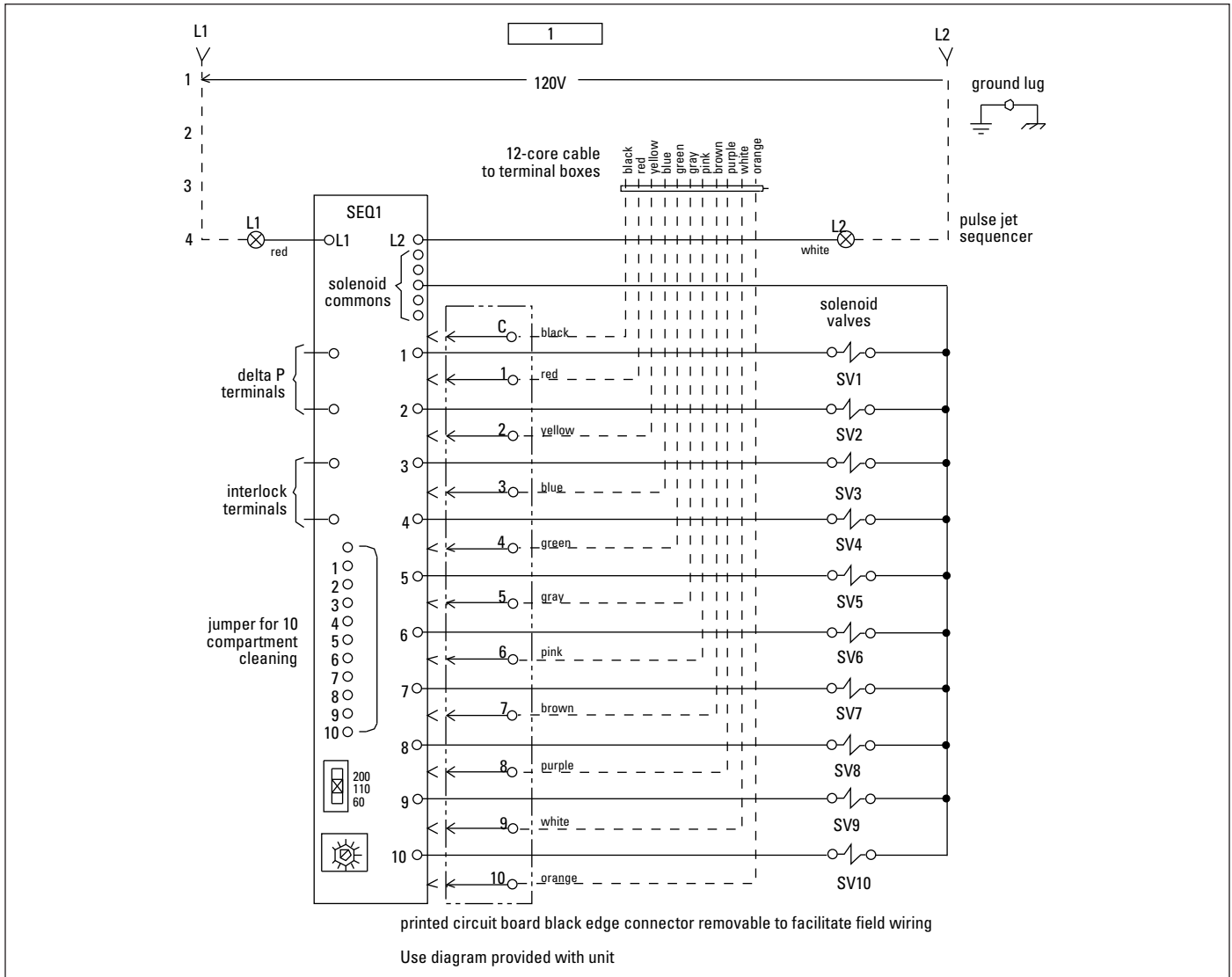

Solid-State Timer Typical Wiring Diagram

Compressed Air Installation



WARNING Turn compressed-air supply OFF and bleed lines before performing service or maintenance work.

A safety exhaust valve should be used to isolate the compressed air supply. The safety exhaust valve should completely exhaust pressure from the collector when closed and include provisions to allow closed-position locking.

Do not set compressed-air pressure above 100-psig. Component damage can occur.

All compressed air components must be sized to meet the maximum system requirements of 90-psig supply pressure.

The compressed-air supply must be oil and moisture free. Contamination in the compressed air used to clean filters will result in poor cleaning, cleaning valve failure, or poor collector performance.

Purge compressed-air lines to remove debris before connecting to the unit's compressed-air manifold.

Using Existing Compressed-Air Supply

Install a customer-supplied shut-off valve, bleed-type regulator with gauge, filter, and automatic condensate valve in the compressed-air supply line to the unit.

Using Compressor-Supplied Compressed-Air

1. Use a compressor of adequate capacity. An overloaded compressor will produce contaminated, moisture-laden air.
2. Avoid locating the air intake in an excessively polluted area and install an air intake filter.
3. The piping between the compressor and the unit should act as a cooling device for the compressed air. A typical requirement for a smaller installation would be 30-ft of 1/2-in diameter pipe. Install the pipe to provide a fall in the direction of airflow to assist drainage of accumulated moisture.
4. Install a customer-supplied shut-off valve, bleed-type regulator with gauge, filter, and automatic condensate valve in the compressed-air supply line.

Compressed Air Requirements

Model	Compressed Air Pressure*	Pulse Duration, millisecond	Pipe Diameter, inches***
DLMV 4/7, 6/10, and 9/15	65 psi	200	1/2
DLMV 7/7, 10/10, and 15/15	65 psi	200	1/2
DLMV 8/7, 12/10, and 18/15	90 psi	200	1/2
DLMV 14/7, 20/10, 5-valve	90 psi	200	1/2
at 12-second intervals*			
DLMV 21/7 and 30/10	75 psi	60	1/2
DLMV 30/15	65 psi	110	1/2
DLMV 45/15	75 psi	110	1/2
DLMV 60/15	90 psi	110	1/2

* Normal operating pressure

** Recommended initial setting

*** Up to 100 ft

Preliminary Start-Up

Instruct all personnel on safe use and maintenance procedures.

WARNING

Electrical work during installation must be performed by a qualified electrician and comply with all applicable national and local codes.

Turn power off and lock out electrical power sources before performing service or maintenance work.

Turn compressed air supply OFF and bleed lines before performing service or maintenance work.

Check that the collector is clear and free of all debris before starting.

Do not install in classified hazardous atmospheres without an enclosure rated for the application.

Optional fans over 600 lbs must be independently supported.

1. Check all electrical connections for tightness and contact.
2. Motor and fan should be wired for clockwise rotation when viewed from the back of the motor.

To reverse rotation, single-phase power supply:
Follow manufacturer's instructions on the motor's nameplate.

To reverse rotation, three-phase power supply:
Turn electrical power OFF at source and switch any two leads on the motor junction box.

WARNING

Do not interchange a power lead with the ground wire. Severe damage or personal injury may result.

3. All access panels should be sealed and secure.
4. Check that the dust container is properly sealed and clamped.
5. Check that exhaust damper is set to the fully-closed position.
6. Check and remove all loose items in or near the inlet and outlet of the unit.

7. Check that all remote controls and solenoid enclosures (if applicable) are properly wired and all service switches are in the OFF position.
8. Check that all optional accessories are installed properly and secured.
9. Turn power ON at source.
10. Turn the compressed-air supply ON. Adjust pressure regulator for setting in Compressed Air Requirements table.

Start-Up

1. Turn compressed-air supply ON.
2. Turn the equipment being served ON.
2. Turn timing controls ON.
3. Turn main fan ON, if equipped.

Shut Down

Follow this shutdown procedure to clear residual deposits from the filter bags, filter body, and equipment served:

1. Turn main fan OFF, leaving compressed air supply ON to allow off-line filter cleaning.

Note: Contact your Donaldson representative for shutdown instructions for explosion vented units.

2. Wait 10 to 15 minutes and turn timing controls and compressor OFF.

Maintenance Information

Instruct all personnel on safe use and maintenance procedures.

⚠ WARNING

Use proper equipment and adopt all safety precautions needed for servicing equipment. Electrical service or maintenance work must be performed by a qualified electrician and comply with all applicable national and local codes.

Turn power off and lock out electrical power sources before performing service or maintenance work.

Do not install in classified hazardous atmospheres without an enclosure rated for the application.

Turn compressed air supply OFF and bleed lines before performing service or maintenance work.

NOTICE

Do not set compressed-air pressure above 100-psig.

Component damage can occur.

All compressed air components must be sized to meet the maximum system requirements of 90-psig supply pressure.

The compressed-air supply must be oil and moisture free. Contamination in the compressed air used to clean filters will result in poor cleaning, cleaning valve failure, or poor collector performance.

Purge compressed air lines to remove debris before connecting to the unit's compressed air manifold.

Operational Checklist

1. Monitor the physical condition of the collector and repair or replace any damaged components.

Routine inspections will minimize downtime and maintain optimum system performance. This is particularly important on continuous-duty applications.

Periodically check the compressed air components and replace compressed air filters.

Drain moisture following the manufacturer's instructions. With the compressed air supply ON, check the cleaning valves, solenoid valves, and tubing for leaks. Replace as necessary.

2. Monitor pressure drop across filters.

Abnormal changes in pressure drop indicate a change in operating conditions and possibly a fault to be corrected. For example, prolonged lack of compressed air will cause an excess build-up of dust on the filters resulting in increased pressure drop. Cleaning off-line with no flow usually restores the filters to normal pressure drop.

3. Monitor exhaust.
4. Monitor dust disposal.

Check Monthly

1. Proper solenoid and diaphragm valve operation.
2. If equipped, check door seals for condition and contact. Replace or adjust as necessary.
3. If equipped, check that the clean-air plenum is free of dust accumulation. If dust is present, check the surrounding filter bags for tears or loose seals.

Check Annually

Moisture Separator

Isolate the compressed-air supply and remove and clean the filter.

Compressed-Air Manifold

Isolate the compressed air supply, remove the drain plug and air inlet connections and clean thoroughly.

Filter Bags

Remove one or two filter bags and inspect for general condition. Replace if necessary.

Jet Tubes

Check that jet tubes are clean and the orifices are clear.

Diaphragm Replacement

1. Remove nylon tubing by pushing inward on the fitting collar and withdraw the tubing.
2. Remove the hex-head set screws and washers securing the valve bonnet.
3. Check that the bleed-hole pin is not blocked.
4. Place the diaphragm over the bleed hole pin with the nylon sealing washer inside the valve throat.
5. Position spring, if equipped, inside the bonnet recess.
6. Replace valve bonnet with the spring over the diaphragm disk shoulder and bonnet over the bleed hole pin. Secure using the hex-head set screws and washers removed in Step 2.
7. Reconnect nylon tubing and secure.

Filter Bag Replacement

1. Activate the pulse cleaning for 10 to 15 minutes to remove excess dust from the filter bags.
2. Remove header cover, if equipped.
3. Remove jet tubes and set aside.
4. Remove the hex nuts securing the wire insert. Remove the clamps and withdraw the insert and filter bag. Inspect insert for excess corrosion, broken mesh, or other damage and replace as necessary.
4. Slide the filter bag over the wire support frame as shown. Slide bag carefully until top of bag is tight against the support frame flange.
5. Place filter bag and wire support assembly in seal frame slots as shown.
6. Position clamps and tighten using a deep well socket and extension. Do not overtighten. Maximum recommended torque is 20 ft/lb.

Note: If filter bags are mounted horizontally, tighten bottom clamp first.
7. Repeat to install all bags.
8. Replace jet tubes with the open end pressed firmly into its locator and the orifices directed toward the filter bag.

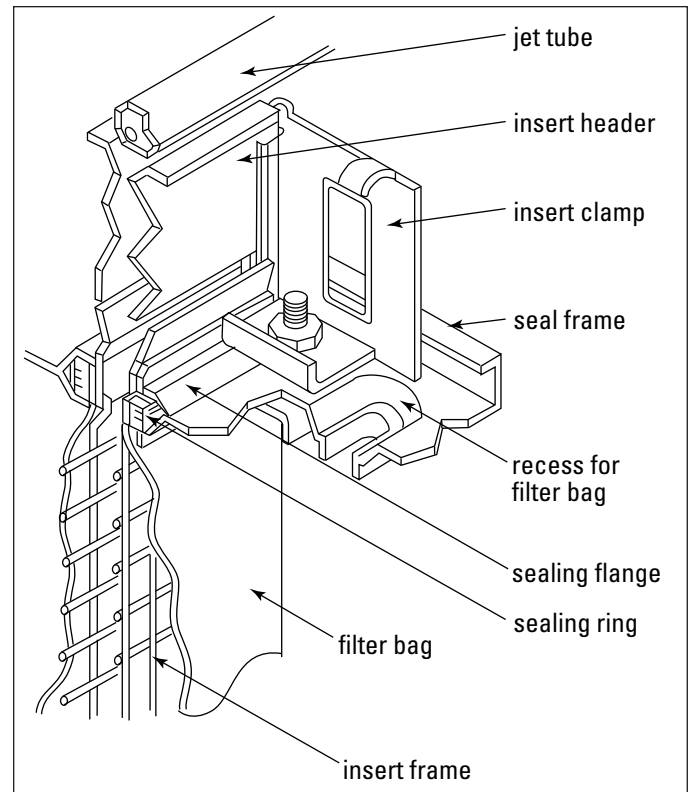

Filter Bag Detail

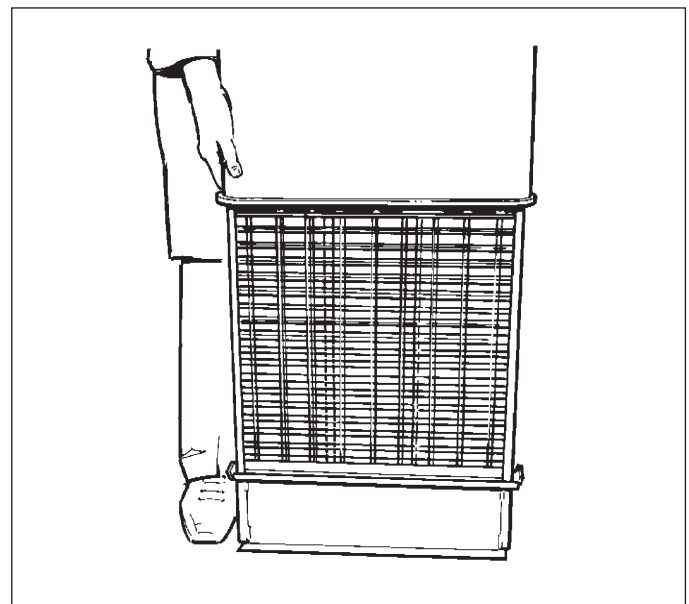

Filter Bag Assembly

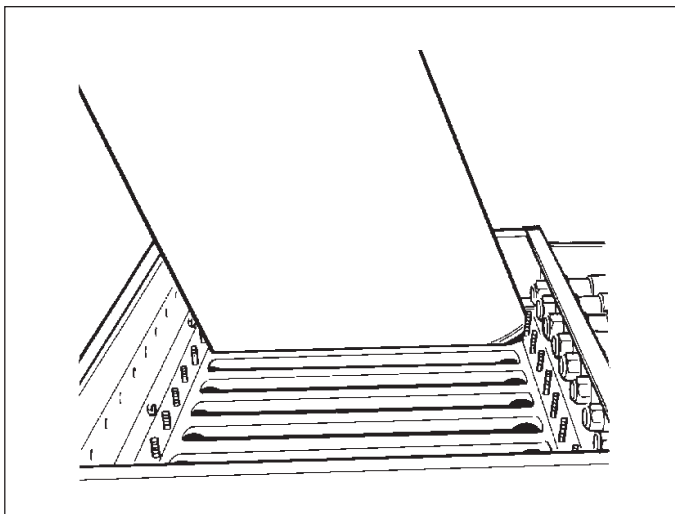

Filter Bag Installation

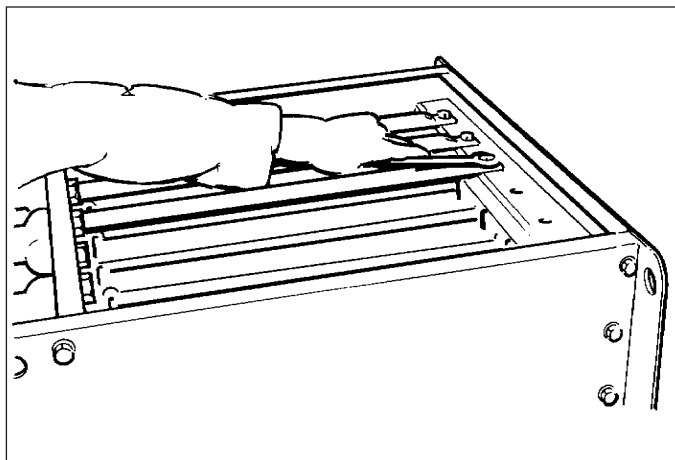

Jet Tube Installation

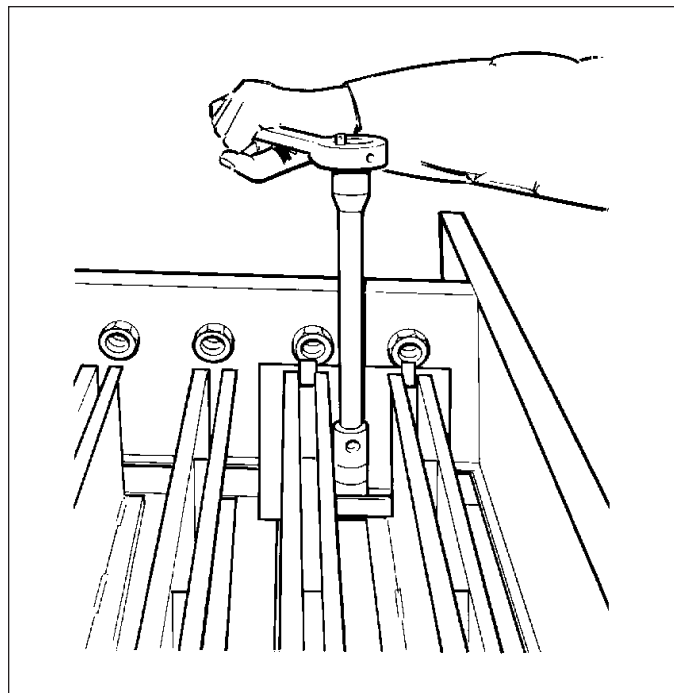

Clamps and Inserts

Compressed Air Components

NOTICE

Do not set compressed-air pressure above 100-psig.

Component damage can occur.

1. Periodically check the compressed air components and replace compressed-air filters.
2. Drain moisture following the manufacturer's instructions.
3. With the compressed-air supply ON, check the cleaning valves, solenoid valves, and tubing for leaks. Replace as necessary.

Optional Equipment

Magnehelic® Gauge

The Magnehelic is a differential pressure gauge used to measure the pressure difference between the clean- and dirty-air plenums and provides a visual display of filter change requirements. The high-pressure tap is located in the dirty-air plenum and the low-pressure tap is located in the clean-air plenum.

1. Choose a convenient, accessible location on or near the unit for mounting that provides the best visual advantage.
2. Plug the pressure ports on the back of the gauge using two, 1/8-in NPT pipe plugs supplied. Install two, 1/8-in NPT male adapters supplied with the gauge into the high- and low-pressure ports on the side of the gauge.
3. Attach the mounting bracket using three, #6-32 x 1/4-in screws supplied.
4. Mount the gauge and bracket assembly to the supporting structure using two, self-drilling screws.
5. Thirty-five feet of plastic tubing is supplied and must be cut in two sections for vacuum pressure systems. Connect one section of tubing from the gauge's high-pressure port to the pressure fitting located in the dirty-air plenum. Connect remaining tubing from the gauge's low-pressure port to the fitting in the clean-air plenum for positive pressure systems, reverse the port connectors. Additional tubing can be ordered from your representative.
6. Zero and maintain the gauge as directed in the manufacturer's Operating and Maintenance Instructions provided.

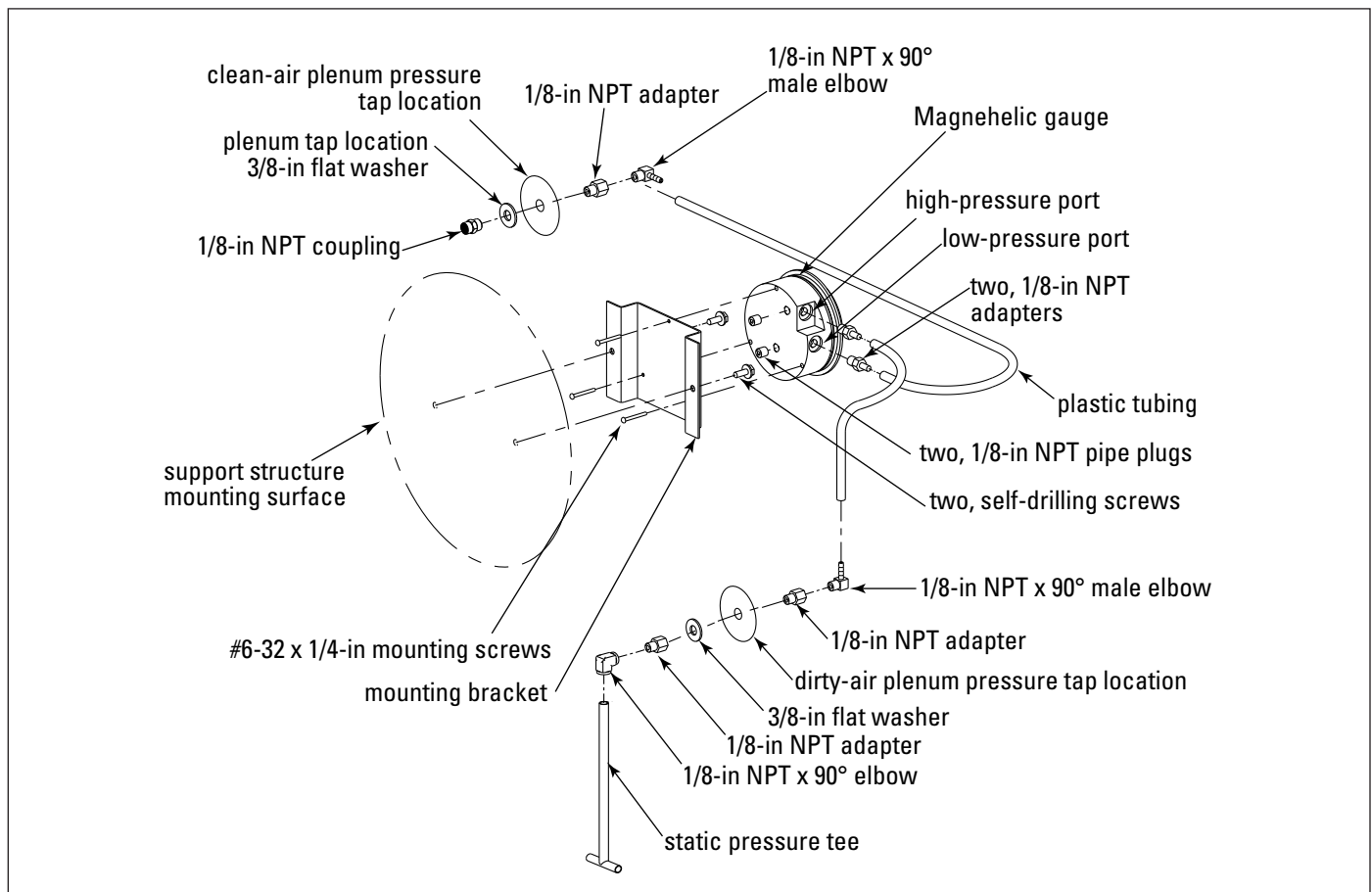

Magnehelic Gauge Installation

Photohelic® Gauge

⚠ WARNING

Electrical service or maintenance work must be performed by a qualified electrician and comply with all applicable national and local codes.

Turn power off and lock out electrical power sources before performing service or maintenance work.

Do not install in classified hazardous atmospheres without an enclosure rated for the application.

The Photohelic combines the functions of a differential pressure gauge and a pressure-based switch. The gauge function measures the pressure difference between the clean- and dirty-air plenums and provides a visual display of filter condition. The high-pressure tap is located in the dirty-air plenum and a low-pressure tap is located in the clean-air plenum. The pressure-based switch function provides high-pressure ON and low-pressure OFF control of the filter cleaning system.

1. Choose a convenient, accessible location near the unit that provides the best visual advantage.
2. Mount the gauge to the remote panel or door using the mounting ring, retaining ring, and four #6-32 x 1 1/4-in screws. Do not tighten screws. Connect two 1/8-in NPT x 1/4-in OD male adapters to the gauge's high- and low-pressure ports. Align the adapters to the 2.375-in hole in the right-hand side of the mounting bracket. Tighten screws.
3. On the back of the gauge, remove four #6-32 x 5/16-in screws and plastic enclosure. Set aside. Add two jumper wires supplied by customer. Remove the jumper from the pressure switch located on the timer board, if equipped. Using the 3/4-in conduit opening, wire the gauge as shown. Reassemble and fasten the enclosure securely.

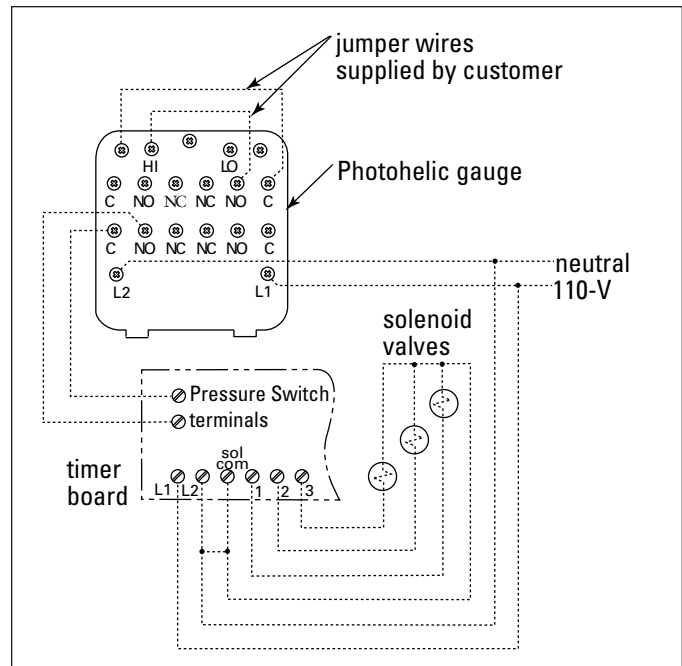

Photohelic Gauge Wiring Diagram

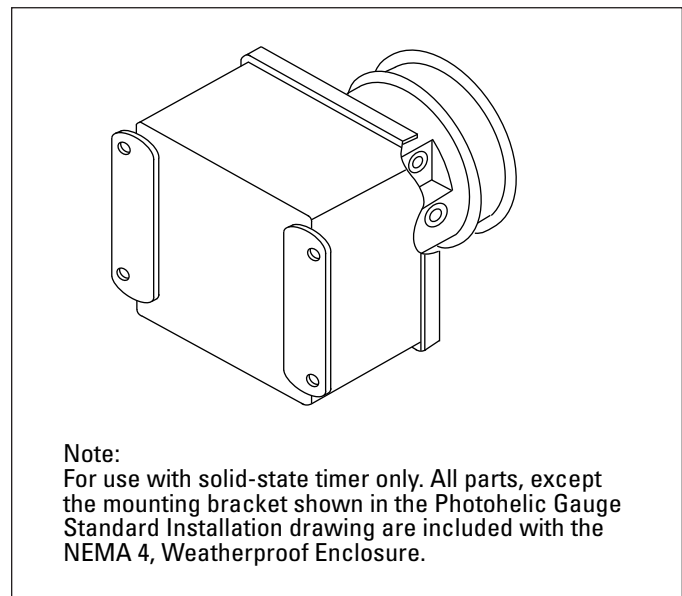

Note:
For use with solid-state timer only. All parts, except the mounting bracket shown in the Photohelic Gauge Standard Installation drawing are included with the NEMA 4, Weatherproof Enclosure.

Photohelic Gauge in Optional NEMA 4 Weatherproof Enclosure

4. Thirty-five feet of plastic tubing is supplied and must be cut in two sections for vacuum systems. Connect one section of tubing from the gauge's high-pressure port to the pressure fitting located in the dirty-air plenum. Connect remaining tubing from the gauge's low-pressure port to the fitting in the clean-air plenum for positive pressure systems, reverse the high and low pressure port connections. Additional tubing can be ordered from your representative.
5. Zero and maintain the gauge as directed in the manufacturer's Operating and Maintenance Instructions provided.
6. To install the Photohelic Gauge mounted in a NEMA 4, Weatherproof Enclosure, follow Steps 4 and 5.

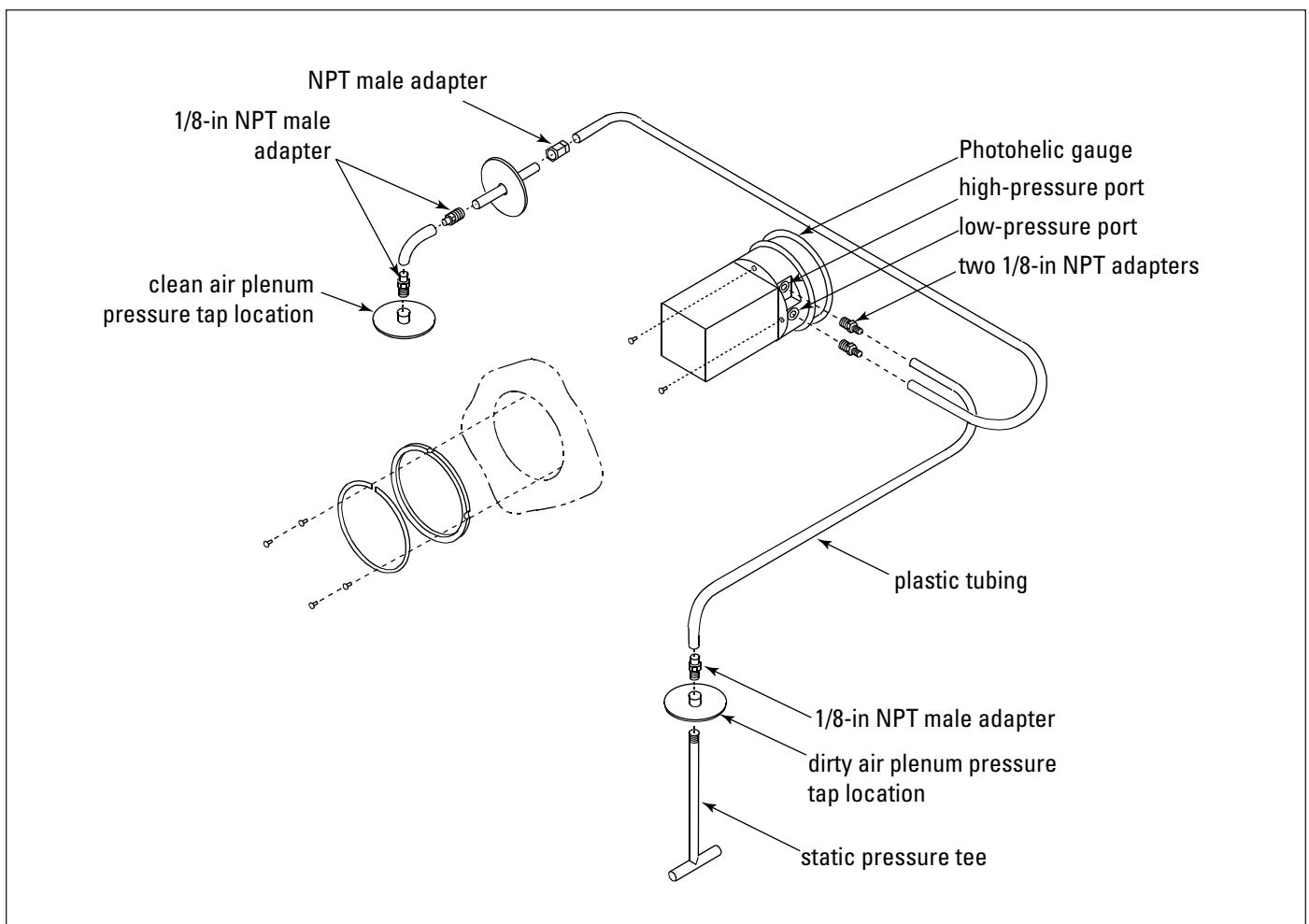

Photohelic Gauge, Remote Panel or Door Installation

Delta P Control

Description

The Delta P Controller monitors the differential pressure between the clean and dirty air plenums, providing a visual display of the filter condition. When combined with a pulse timer, it controls the pressure drop by turning the cleaning mechanism On and Off at the chosen limits. There are three (3) set points: High Pressure On, Low Pressure Off, and Alarm. The first two, High Pressure On and Low Pressure Off, control the filter cleaning system. The third, Alarm, provides a relay output to activate an external alarm supplied by others.

Operation

Normal

The Delta P Controller monitors the pressure in the clean and dirty air plenums while the unit is running. The blower draws air through the filters, creating a pressure drop. The Delta P Controller measures the pressure drop and provides a visual display in inches water gauge or metric (SI) units of daPa.

Filter Cleaning

When the pressure drop across the filters reaches the High Pressure On setpoint, the controller closes an output relay allowing a timer to trigger the cleaning valves sequentially. When the controller senses that the pressure drop has decreased to the Low Pressure Off setpoint, the relay opens and the cleaning cycle stops. This sequence continues as long as the collector is in use, maintaining the pressure drop within a narrow range.

Alarm

The Alarm setpoint is set to a higher setting than the High Pressure On setpoint used to start the filter cleaning cycle. It indicates situations when the cleaning system cannot reduce the pressure drop due to cleaning system failure, lack of compressed air, or the end of the filter's useful life. There is a time delay prior to setting the Alarm to prevent nuisance trips. The Delta P Controller also provides an input connection for a remote alarm reset.

For complete information, see the most current version of the Delta P Installation, Operation, and Maintenance manual.



Delta P Control

Delta P Plus Control

Description

The Delta P Plus Controller monitors the differential pressure between the clean and dirty air plenums, providing a visual display of the filter condition. When combined with a pulse timer, it controls the pressure drop by turning the cleaning mechanism On and Off at the chosen limits. There are three (3) set points: High Pressure On, Low Pressure Off, and Alarm. The first two, High Pressure On and Low Pressure Off, control the filter cleaning system. The third, Alarm, provides a relay output to activate an external alarm supplied by others.

The user can program the Delta P Plus Controller to pulse while the collector is running, to maintain a relatively constant pressure drop across the filters, pulse only after the collector is shut down (after-shift cleaning), or a combination of both, cleaning while running as well as end of the shift.

Operation

Normal

The Delta P Plus Controller monitors the pressure on both sides of the tubesheet while the unit is running. As air flows through the filters, the resistance of the media and collected dust creates a pressure difference or "drop" between the dirty and clean air plenums. The Delta P Plus Controller measures the pressure drop and provides a visual display in inches water gauge or metric (SI) units of daPa.

Filter Cleaning

The Delta P Plus Controller offers three filter cleaning options.

1. **Differential Pressure Cleaning (DFF)** - When the pressure drop across the filters reaches the Controller's High Pressure On setpoint, the Controller closes an output relay allowing a sequential timer to trigger the cleaning valves. When the Controller senses that the pressure drop has decreased to the Low Pressure Off setpoint, the relay opens and the cleaning cycle stops. This sequence continues as long as the collector is in use, maintaining the pressure drop within a narrow range.

2. **Downtime Cleaning (DTC)** - The Delta P Plus Controller monitors the collection system. When the pressure drop exceeds the Low Pressure Off set point and then approaches zero again, the Delta P Plus Controller runs a delay timer to allow the blower to come to a stop and then engages the cleaning mechanism for a preselected time.
3. **Combined Differential and Downtime Cleaning (ALL)** - The Delta P Plus Controller combines the two functions described above; maintaining the pressure drop in a narrow band and downtime cleaning the filters when the collector is shut down. The downtime cleaning function can be toggled On or Off from the keyboard.

Alarm

The Alarm setpoint is set to a higher setting than the High Pressure On used to start the filter cleaning cycle. It indicates situations when the cleaning system cannot reduce the pressure drop due to cleaning system failure, lack of compressed air, or the end of the filter's useful life. There is a time delay prior to setting the Alarm to prevent nuisance trips. The Delta P Plus Controller also provides an input connection for a remote Alarm reset.

For complete information, see the most current version of the Delta P Plus Installation, Operation, and Maintenance manual.

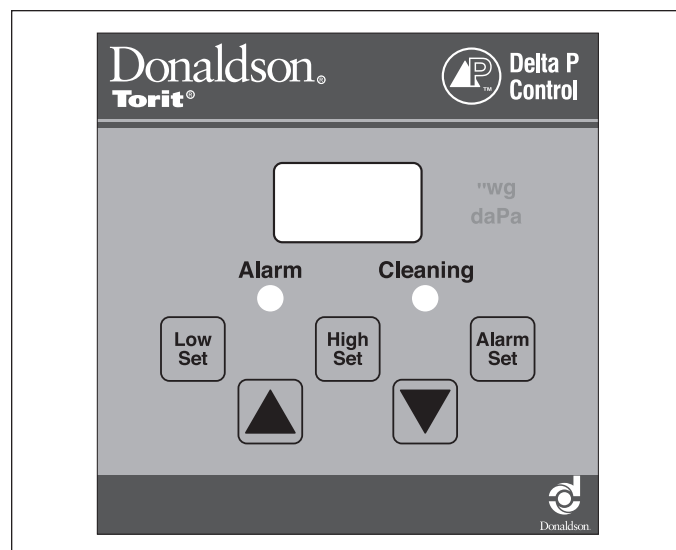

Delta P Control

Antistatic Option

Units using antistatic filter bags must be properly grounded.

1. Remove and replace the standard hardware with the brass hardware as shown.
2. Loop grounding strap from seal frame to seal frame and fasten using existing hardware as shown.
3. Connect a suitable ground wire to the grounding lug located on the side of the collector housing.

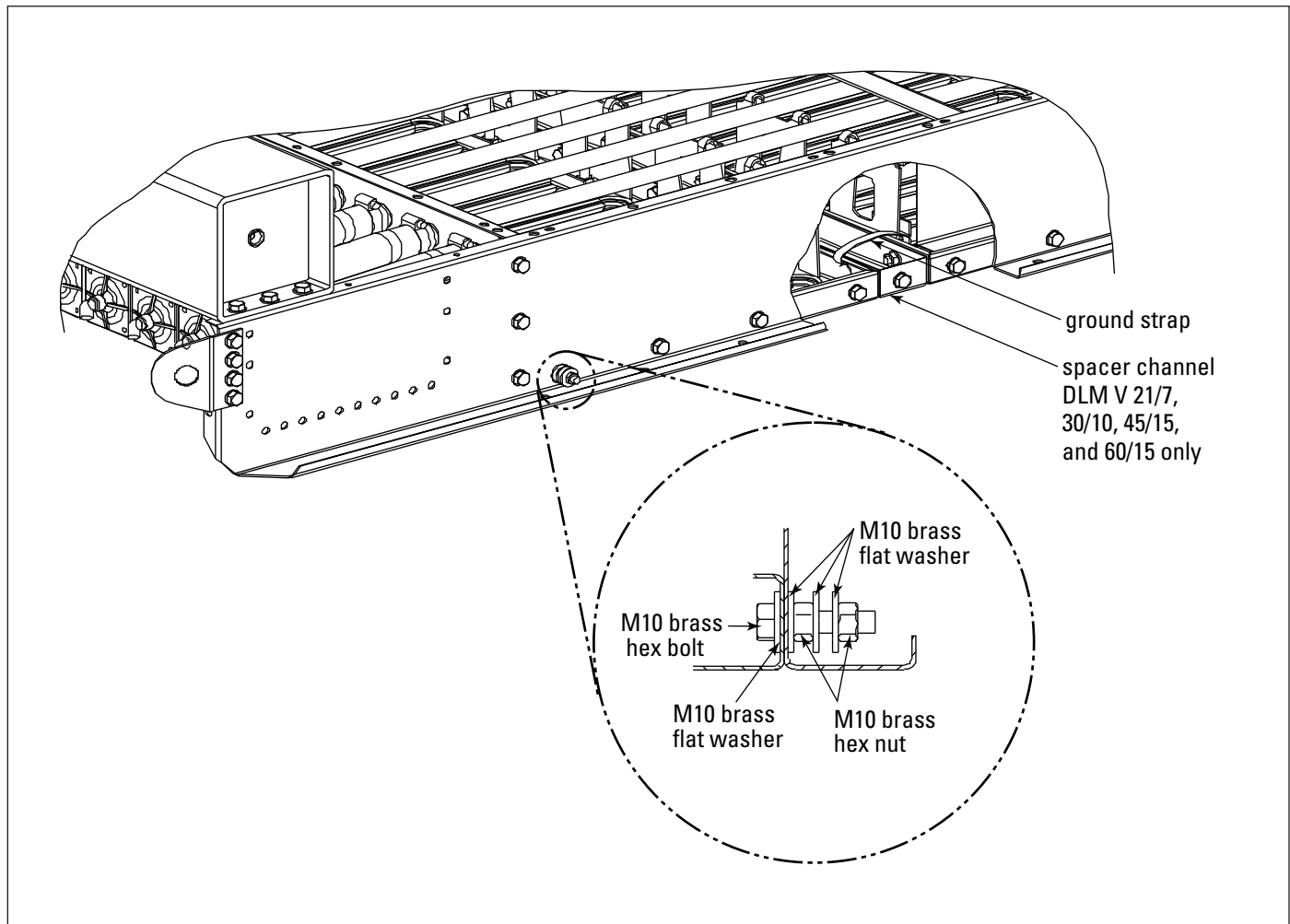

Antistatic Ground Connection

Explosion Relief Vents

Contact an independent explosion expert to ensure proper explosion protection design for integrated equipment such as bins, silos, hoods, mixers, and crushers.



WARNING

Personal injury, death, or property damage can result from material discharge during venting.

The material discharged during the venting of an explosion must be safely directed outdoors away from areas occupied by personnel to reduce risk of personal injury or property damage.

The risk of injury or damage can be minimized or avoided by locating vented equipment outside buildings and away from normally occupied areas.

Explosion vents should be inspected regularly to confirm physical and operational condition. Replace any damaged parts immediately.

Standard explosion vents are intended for outdoor installations only.

Troubleshooting

Problem	Probable Cause	Remedy
Blower fan and motor do not start	Improper motor wire size	Rewire using the correct wire gauge as specified by national and local codes.
	Not wired correctly	Check and correct motor wiring for supply voltage. See motor manufacturer's wiring diagram. Follow wiring diagram and the National Electric Code.
	Unit not wired for available voltage	Correct wiring for proper supply voltage.
	Input circuit down	Check power supply to motor circuit on all leads.
	Electrical supply circuit down	Check power supply circuit for proper voltage. Check for fuse or circuit breaker fault. Replace as necessary.
Insufficient airflow	Faulty interlock	Check and replace if necessary.
	Excess moisture in the compressed air supply	Check that the compressed air supply is oil and moisture free.
	No pulse to diaphragm valves	Check the vent opening on the solenoid valve for pulse. If all valves are affected, check that the LED LP1 on the controller is ON. If not illuminated, check power supply and printed circuit board fuse. If illuminated, check that the interrupt function is not enabled. If interrupt function is not enabled and still no pulse, replace the printed circuit board. If isolated solenoid or diaphragm valve is affected, check LED LP3 on the controller that flashes corresponding to the malfunctioning valve. If illuminated, replace solenoid valve. Replace printed circuit board if LED is not illuminated.
	Filters plugged	Check that the dust storage silo or bin is not full or that the equipment served is operating. Turn fan OFF and allow the controller to perform several complete cleaning cycles. Remove each filter bag, vacuum outside surfaces, and replace. Replace damaged or torn filter bags.
	Verify remedy as it talks about vacuuming filter bag	
	Fan rotation backwards	Proper fan rotation is clockwise from the top of the unit. The fan can be viewed through the back of the motor. See Preliminary Start-Up Check.
Clean-air outlet discharging dust	Filter bags not installed correctly	See Filter Installation.
	Filter damage or holes in media	Replace filters as necessary. Use only genuine Donaldson replacement parts. See Filter Installation.

The Donaldson Torit Warranty

Donaldson warrants to the original purchaser that the major structural components of the goods will be free from defects in materials and workmanship for ten (10) years from the date of shipment, if properly installed, maintained and operated under normal conditions. Donaldson warrants all other Donaldson built components and accessories including Donaldson Airlocks, TBI Fans, TRB Fans, Fume Collector products, Donaldson built electrical control components and Donaldson built Afterfilter housings for twelve (12) months from date of shipment. Donaldson warrants Donaldson built filter elements to be free from defects in materials and workmanship for eighteen (18) months from date of shipment. Donaldson does not warrant against damages due to corrosion, abrasion, normal wear and tear, product modification, or product misapplication. Donaldson also makes no warranty whatsoever as to any goods manufactured or supplied by others including electric motors, fans and control components. After Donaldson has been given adequate opportunity to remedy any defects in material or workmanship, Donaldson retains the sole option to accept return of the goods, with freight paid by the purchaser, and to refund the purchase price for the goods after confirming the goods are returned undamaged and in usable condition. Such a refund will be in the full extent of Donaldson's liability. Donaldson shall not be liable for any other costs, expenses or damages whether direct, indirect, special, incidental, consequential or otherwise. The terms of this warranty may be modified only by a special warranty document signed by a Director, General Manager or Vice President of Donaldson. Failure to use genuine Donaldson replacement parts may void this warranty. THERE EXIST NO OTHER REPRESENTATIONS, WARRANTIES OR GUARANTEES EXCEPT AS STATED IN THIS PARAGRAPH AND ALL OTHER WARRANTIES INCLUDING MERCHANTABILITY AND FITNESS FOR A PARTICULAR PURPOSE, WHETHER EXPRESS OR IMPLIED ARE HEREBY EXPRESSLY EXCLUDED AND DISCLAIMED.



Donaldson
FILTRATION SOLUTIONS

Parts and Service

For genuine Donaldson replacement filters and parts, call the Parts Express Line. For faster service, have unit's model and serial number, quantity, part number, and description available.

Donaldson Company, Inc.
Torit
PO Box 1299
Minneapolis, MN 55440-1299
U.S.A.

800-365-1331 USA
800-343-3639 within Mexico

donaldsontorit@donaldson.com
donaldsontorit.com

Donaldson Company, Inc. is the leading designer and manufacturer of dust, mist, and fume collection equipment used to control industrial-air pollutants. Our equipment is designed to help reduce occupational hazards, lengthen machine life, reduce in-plant maintenance requirements, and improve product quality.

© 2002 Donaldson Company, Inc.
Printed in USA

IOM 7592601 (ENG), Revision 5
April 2011