

Torit Radial Blade (TRB) Fans provide a convenient, cost-effective method of integrating a high efficiency fan with a Donaldson® Torit® dust collector.

- Mounts directly to the clean-air plenum of the dust collector, eliminating costly transition ducting, and reducing footprint of the system.
- Sizes range from 1 to 10 hp.
- Direct-drive operation eliminates maintenance of fan bearings and belts.
- Computer balanced fan and motor assembly ensures vibration-free operation.
- High temperature design operates up to 200°F/93°C.
- All necessary hardware for quick and easy installation is included.
- Aluminum fan wheel ensures compliance with safety regulations and meets AMCA C spark resistant requirements.
- Standard paint finish is blue.
- All 60 Hz motors are compliant with the Energy Independence and Security Act of 2007 (EISA).



TRB-5 (60 Cycle)

EQUIPMENT OPTIONS

Explosion-proof motors – NEMA	60 cycle NEMA or 50 cycle IEC motor configurations
Outlet dampers	Outlet guards
Chamber silencers	

TORIT RADIAL BLADE FANS

DIMENSIONS & SPECIFICATIONS FOR 60 CYCLE TRB FAN

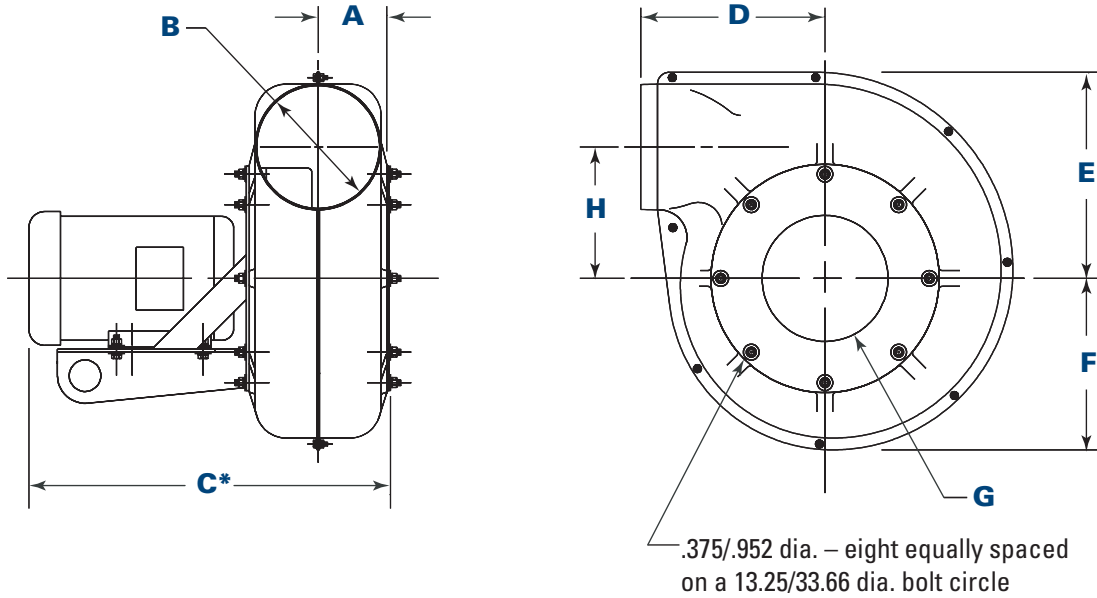

60 Cycle Fans	Dimensions																Shipping Weight	
	A		B		C*		D		E		F		G		H		(lbs)	(kg)
	(in)	(cm)	(in)	(cm)	(in)	(cm)	(in)	(cm)	(in)	(cm)	(in)	(cm)	(in)	(cm)	(in)	(cm)		
TRB-1	5.4	13.7	5.9	15.1	13.8	34.9	8.9	22.6	11.0	27.9	9.3	23.5	6.0	15.2	7.3	18.5	48	22
TRB-2	5.4	13.7	5.9	15.1	15.5	39.4	8.9	22.6	11.0	27.9	9.3	23.5	7.0	17.8	7.3	18.5	63	29
TRB-3	4.4	11.1	7.9	20.2	17.4	44.3	11.7	29.7	13.1	33.3	10.2	25.8	8.0	20.3	8.3	21.2	87	39
TRB-5	4.4	11.1	7.9	20.2	22.9	58.1	11.7	29.7	13.1	33.3	10.2	25.8	8.0	20.3	8.3	21.2	124	56
TRB-7.5	4.4	11.1	7.9	20.2	24.3	61.6	11.7	29.7	13.1	33.3	10.2	25.8	10.0	25.4	8.3	21.2	148	67
TRB-10	4.4	11.1	7.9	20.2	24.3	61.6	11.7	29.7	13.1	33.3	10.2	25.8	10.0	25.4	8.3	21.2	227	103

* This dimension is subject to change based on the motor manufacturer chosen and on the motor enclosure type (TEFC or EP). If this dimension is critical, you should verify the information with your sales representative.

PERFORMANCE CURVES FOR 60 CYCLE TRB FAN

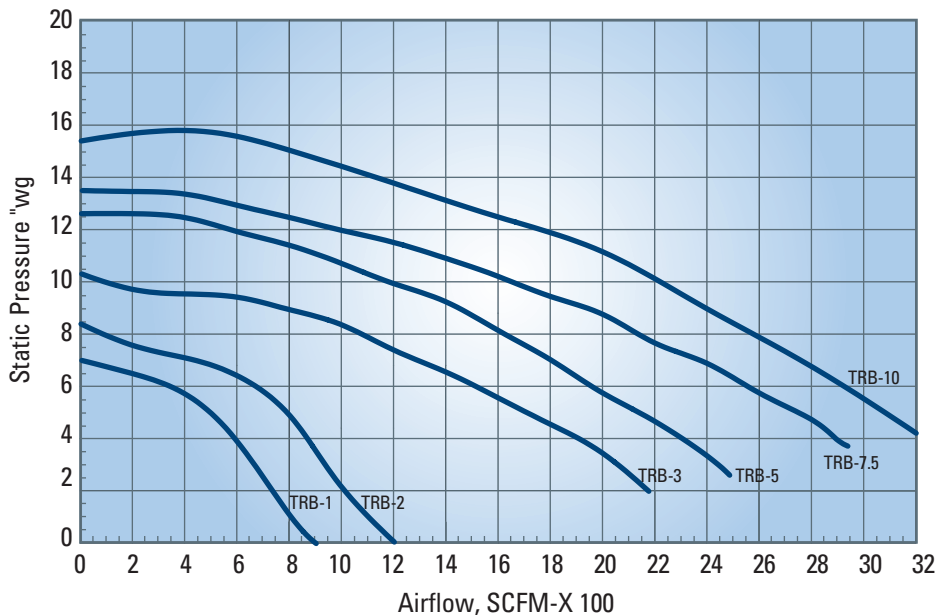

TORIT RADIAL BLADE FANS

DIMENSIONS & SPECIFICATIONS FOR 50 CYCLE TRB FAN

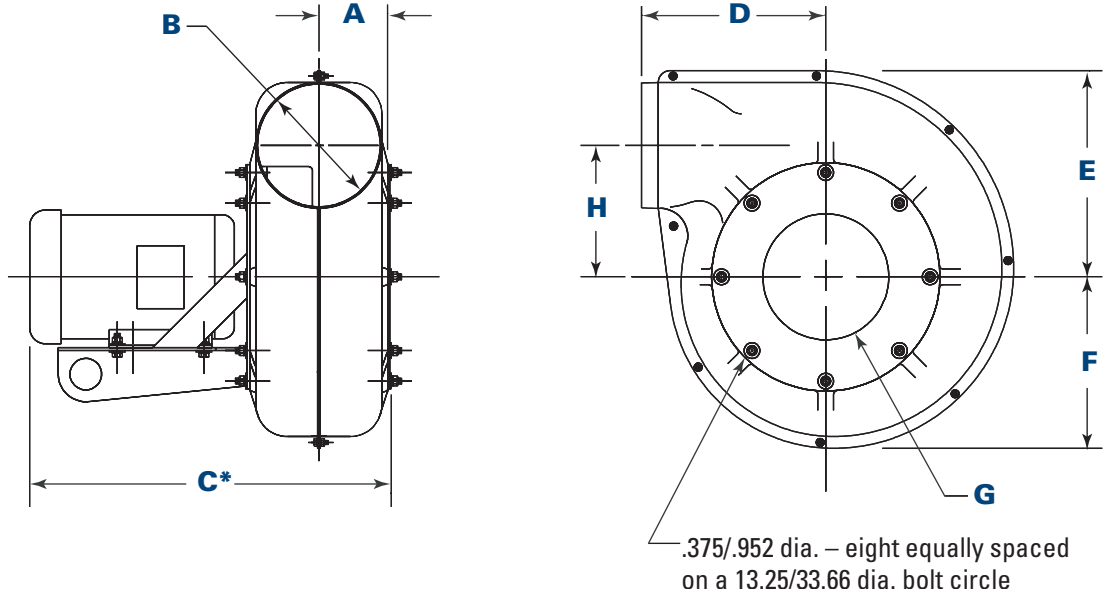

50 Cycle Fans	Dimensions																Shipping Weight	
	A		B		C*		D		E		F		G		H		(lbs)	(kg)
	(in)	(cm)	(in)	(cm)	(in)	(cm)	(in)	(cm)	(in)	(cm)	(in)	(cm)	(in)	(cm)	(in)	(cm)		
TRB-1	5.4	13.7	5.9	15.1	15.3	38.5	8.9	22.6	11.0	27.9	9.3	23.5	7.0	17.8	7.3	18.5	63	29
TRB-2	4.4	11.1	7.9	20.2	19.1	48.9	11.7	29.7	13.1	33.3	10.2	25.8	6.0	15.2	8.3	21.2	88	40
TRB-3	4.4	11.1	7.9	20.2	20.1	51.0	11.7	29.7	13.1	33.3	10.2	25.8	10.0	25.4	8.3	21.2	100	45
TRB-5	4.4	11.1	7.9	20.2	22.2	56.4	11.7	29.7	13.1	33.3	10.2	25.8	10.0	25.4	8.3	21.2	158	72
TRB-7.5	4.4	11.1	7.9	20.2	23.7	60.3	11.7	29.7	13.1	33.3	10.2	25.8	10.0	25.4	8.3	21.2	205	93

* This dimension is subject to change based on the motor manufacturer chosen and on the motor enclosure type (TEFC or EP). If this dimension is critical, you should verify the information with your sales representative.

PERFORMANCE CURVES FOR 50 CYCLE TRB FAN

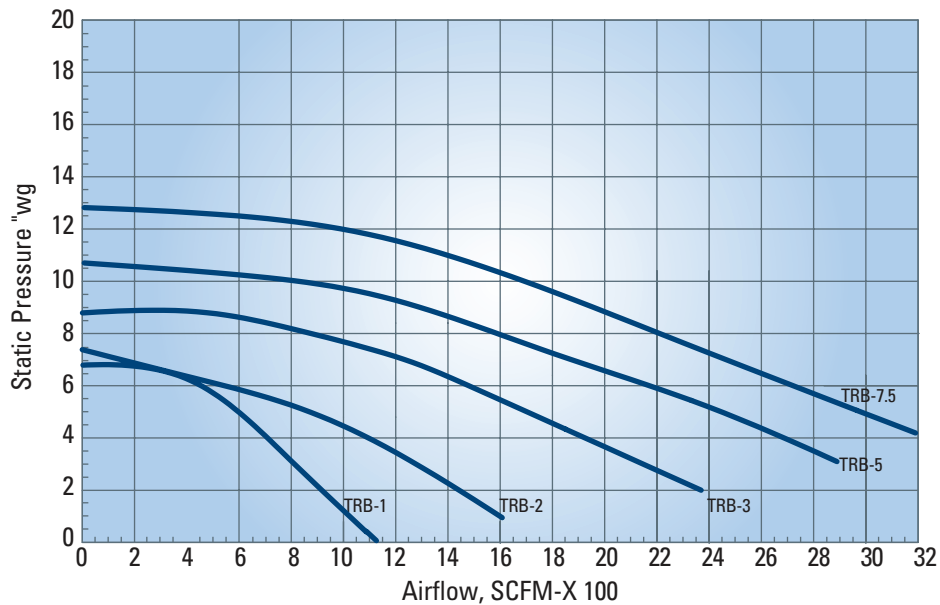

TORIT RADIAL BLADE FANS

60 CYCLE TRB FAN SOUND DATA*

Model	Unsilenced ¹	Silenced ²
TRB-1	85	75
TRB-2	87	77
TRB-3	91	81
TRB-5	93	83
TRB-7.5	95	85
TRB-10	97	87

50 CYCLE TRB FAN SOUND DATA*

Model	Unsilenced ¹	Silenced ²
TRB-1	85	75
TRB-2	89	79
TRB-3	92	82
TRB-5	94	84
TRB-7.5	96	86
TRB-10	N/A	N/A

* dB(A) sound levels are an average of measurements made in a laboratory environment. Installed sound levels will vary depending on the measurement location, operating conditions, and installation.

1 Overall average dB(A) unsilenced fan at one meter.

2 Overall average dB(A) silenced fan at one meter. Allow 1"wg restriction for 1-3 hp fans and 2" for 5-10 hp fans.

Significantly improve the performance of your collector with genuine Donaldson Torit replacement filters and parts. [Browse our catalog at donaldson.com](https://www.donaldson.com)



Donaldson Company, Inc.
Torit
P.O. Box 1299
Minneapolis, MN
55440-1299 U.S.A.

Tel 800-365-1331 (USA)
Tel 800-343-3639 (within Mexico)

donaldson.com
[donaldson.com](https://www.donaldson.com)



Data Sheet TRB Fans (08/11)

© 1998 Donaldson Co., Inc. All Rights Reserved. Information in the document is subject to change without notice. Donaldson Torit is a registered trademark of Donaldson Company, Inc. Contains Donaldson proprietary technology.