

ULTRA-WEB®
High Efficiency Nanofiber Filters Built to Last

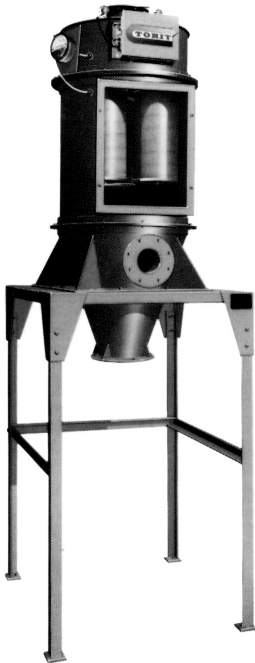

TD-162



TD-486

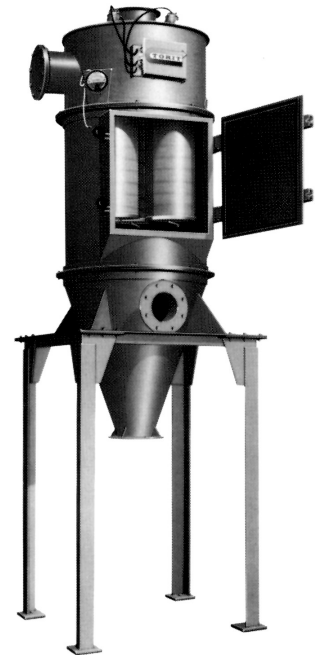

TD-573

Standard and high pressure pulse-jet dust collectors provide on-line filter cleaning allowing continuous-duty operation.

- Ultra-Web® cartridge filters featuring nanofiber technology optimize high filtration efficiency and long filter life.
- MERV* 13 filtration efficiency rating per ASHRAE 52.2-2007.
- The compact design is ideal for bin venting applications where space is at a premium.
- Lower operating pressure drop reduces energy costs.
- Optional tangential inlet on round TD housings preseparates dust for high-loading applications.
- Provides a cleaner work environment for maximum productivity.
- Helps support OSHA Clean Air Standards.

TD DUST COLLECTORS

DIMENSIONS & SPECIFICATIONS

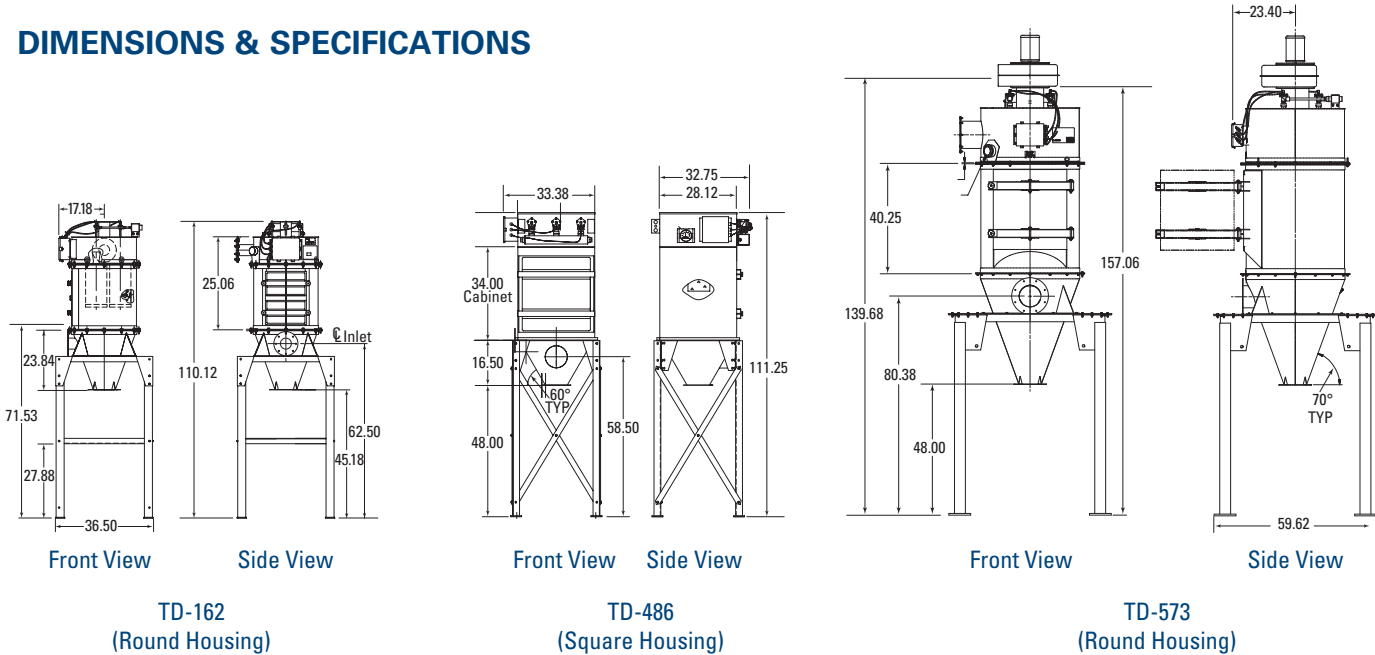

Model	Nominal Airflow** (cfm)	Ultra-Web® Filter Area (ft²)	No. of Filters	No. of Valves	Housing Rating	Shipping Weight (lbs)
TD-162	300 - 400	180	3	3	-220 "wg	450
TD-486	700 - 1500	540	9	3	±20 "wg	500
TD-573	1000 - 1100	510	3	3	-220 "wg	1350

EQUIPMENT OPTIONS

- Cartridge filter options:
 - Ultra-Web FR (MERV 13)
 - Fibra-Web® (MERV 14)
 - Ultra-Web SB (MERV 15)
 - Torit-Tex™ (MERV 16)
 - Ultra-Tek® (MERV 12)
- 1, 2, 3, 5, 7.5, and 10 hp blowers
- Solid-state timer
- Adjustable damper (blower)
- Explosion vents
- Magnehelic®† gauge
- Photohelic®† gauge
- Bolt-on support legs
- Inlet adapters
- Hopper discharge
 - Slide gate pack
 - 5-gallon pail pack
 - 55-gallon drum cover
 - Rotary airlock

* The Minimum Efficiency Reporting Value (MERV) of this filter cartridge has been determined through independent laboratory testing using ASHRAE 52.2 (2007) test standards. The MERV rating was determined at a face velocity of 118 feet per minute and loading up to four inches water gauge. Actual efficiency of any filter cartridge will vary according to the specific application parameters. Dust concentration, airflow, particle characteristics, and pulse cleaning methods all affect filtration efficiency.

** Based on clean filters.

*** Weight is for 155-68° hopper arrangement without fan.

† Magnehelic and Photohelic are registered trademarks of Dwyer Instruments, Inc.

Significantly improve the performance of your collector with genuine Donaldson Torit replacement filters and parts. [Browse our catalog at donaldson.com](http://donaldson.com)



Donaldson Company, Inc.
Torit
P.O. Box 1299
Minneapolis, MN
55440-1299 U.S.A.

Tel 800-365-1331 (USA)
Tel 800-343-3639 (within Mexico)

donaldson.com
donaldson.com



Data Sheet TD Dust Collectors (08/11)

© 2000 Donaldson Co., Inc. All Rights Reserved. Information in the document is subject to change without notice. Donaldson Torit and Ultra-Web are registered trademarks of Donaldson Company, Inc. Contains Donaldson proprietary technology.