



**460-IRD**

(shown with optional shaker)

An easy and economical solution for a wide range of wood dust collection applications.

- Complete dust collection package includes fan, fan motor, push-button fan starter, bag filters and clear plastic dust disposal bags.
- Fan provides high vacuum pressure with low operating sound levels for cleaner workplaces and lower sound levels.
- Down flow air pattern allows airflow and gravity to move filtered dust to collection receptacles for longer bag filter life and reduced pressure drop.
- Adjustable airflow baffles equalize dust dispersion to all collection receptacles, which minimizes emptying cycles.
- Cageless filters and tool-free filter replacement reduce maintenance time.
- Filtered air returning to interior workspace reduces HVAC costs.
- Dura-Life™ "Twice the Life" bag filters provide longer bag life, which reduces maintenance costs and lowers pressure drop.
- Optional automatic shaker is available for better collector performance.
- Fans with higher static pressure are available for more demanding applications.

# IRD DUST COLLECTORS

## OPERATIONAL EXPLANATION

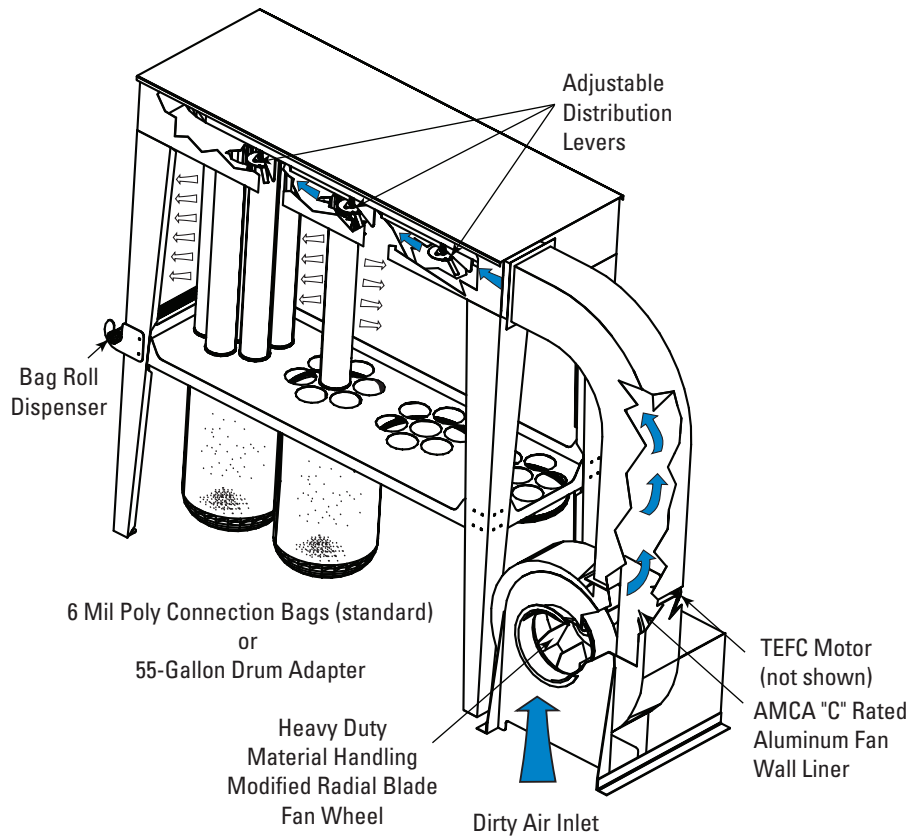

Dust laden air is pushed into the dirty air plenum by a high volume, high pressure heavy duty material handling fan. The dusty air is evenly distributed down inside of the high flow polyester bags which capture the dust and allow clean air to pass back into the work environment.

Dust captured inside the bag is carried down into the dust receptacles at the bottom of the collector via gravity and airflow. An optional automatic shaker is available for even better collector performance.

Model	Fan (hp)	Air Volume (cfm) / Static Pressure at Fan Inlet ("wg)*							
		6	7	8	9	10	11	12	13
260-IRD-5R**	5	—	—	—	—	1550	1450†	1350	1225
260-IRD-7.5	7.5	3600	2350	—	—	—	—	—	—
360-IRD-7.5R	7.5	—	—	—	—	2175	2025	1850	1650
360-IRD-10	10	—	—	3700	2850	2125	—	—	—
360-IRD-10R	10	—	—	—	—	2900	2675	2450	2250
360-IRD-15	15	—	—	4800	4050	2400	—	—	—
460-IRD-15	15	—	—	4800	4050	2400	—	—	—
460-IRD-15R	15	—	—	—	—	5050	4350	3900	—
460-IRD-20	20	—	—	6875	6375	5875	5325	—	—

\* Table data allows for 2 "wg collector loss with clean bag filters.

\*\* Models with "R" at the end have higher static fans.

† Italic type is typical airflow applications.

# IRD DUST COLLECTORS

## DIMENSIONS & SPECIFICATIONS

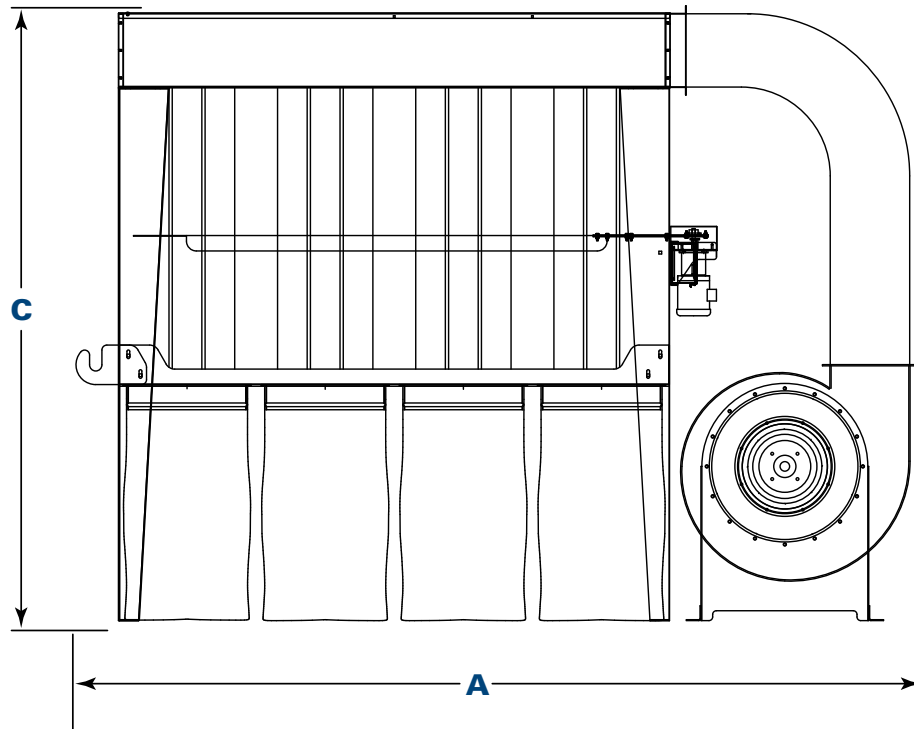

**Model 460-IRD-20**  
(shown w/optional shaker motor)  
Front View

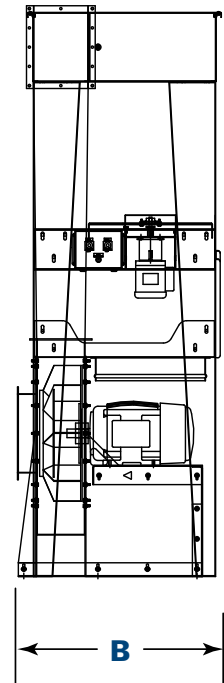

**Model 460-IRD-20**  
Side View

Model	Nominal Airflow Range* (cfm)	Cloth Area (ft <sup>2</sup> )	Number of Bag Filters	No. of Dust Collection Receptacles	Dust Capacity w/ plastic bags (cu ft)	Motor (hp)	Shipping Weight (lbs)	Dimensions (inches)		
								A	B	C
260-IRD-5R**	1350 - 1450	128	14	2	20	5	1100	96.4	43.9	124.6
260-IRD-7.5	2350 - 3600	128	14	2	20	7.5	1360	104.1	45.3	124.6
360-IRD-7.5R	1850 - 2025	192	21	3	30	7.5	1300	124.7	43.9	124.6
360-IRD-10	2850 - 3700	192	21	3	30	10	1710	132.7	44.4	124.6
360-IRD-10R	2450 - 2675	192	21	3	30	10	1350	124.1	43.9	124.6
360-IRD-15	4050 - 4800	192	21	3	30	15	1890	137.1	45.5	124.6
460-IRD-15	4050 - 4800	257	28	4	40	15	2070	165.1	45.5	124.6
460-IRD-15R	3900 - 4350	257	28	4	40	15	2140	170.5	45.1	124.6
460-IRD-20	5875 - 6375	257	28	4	40	20	2200	170.5	45.3	124.6

\* Table data allows for 2 "wg collector loss with clean bag filters.

\*\* Models with "R" at the end have higher static fans.

# IRD DUST COLLECTORS

## STANDARD FEATURES & AVAILABLE OPTIONS

Collector Design	Std	Opt
Down Flow Design	X	
Airflow Balancing Baffles and Levers	X	
Cageless Filter Design	X	
Tool-Free Filter Removal	X	
Minimum 14-Gauge Carbon Steel Construction	X	
12 Gauge Carbon Steel Tubesheet	X	
Integral Dust Disposal Bag Storage Rack	X	
Direct Drive High Output Material Handling Fan	X	
AMCA "C" Rated Aluminum Fan Wall Liner	X	
230/460, 3 Phase TEFC NEMA Premium®* Efficient Motor	X	
Filter-to-Fan Transition	X	
1/3 HP Auto Shaker		X
Exterior Weather Kit		X
<b>Bag Filters</b>		
7" Diameter x 60" Long Dura-Life Polyester Bag Filters	X	

Paint System	Std	Opt
Liquid Alkyd Finish	X	
Standard Colors: Torit Blue or Storm White	X	
<b>Dust Collection Receptacles</b>		
50 - 6 Mil Clear Plastic Disposal Bags with 10 Cubic Foot Capacity	X	
Quick Opening Cam Clamps for Disposal Bag Change	X	
55-Gallon Drum Adapters		X
<b>Support Structure</b>		
10 Gauge Carbon Steel Construction	X	
<b>Electrical Controls, Gauges and Enclosures</b>		
Push Button Magnetic Fan Starter in NEMA 1 Enclosure	X	
Shaker Controls in NEMA 4 Enclosure (comes with the following features) <ul style="list-style-type: none"> <li>• Manual and Automatic Shake Switch</li> <li>• On-Time Automatic Shake Adjustment Dial</li> <li>• Off-Time Automatic Shake Adjustment Dial</li> <li>• 120 Volt Cord</li> </ul>		X
<b>Warranty</b>		
10-Year Warranty	X	

\* All 60 Hz motors 1 HP and above are EISA compliant.  
NEMA Premium is a registered trademark of National Electrical Manufacturers Association.

Significantly improve the performance of your collector with genuine Donaldson Torit replacement filters and parts. [Browse our catalog at donaldson.com](http://donaldson.com)



Donaldson Company, Inc.  
Torit  
P.O. Box 1299  
Minneapolis, MN  
55440-1299 U.S.A.

Tel 800-365-1331 (USA)  
Tel 800-343-3639 (within Mexico)

donaldson.com  
donaldson.com



Data Sheet IRD Dust Collectors (08/11)

© 2008 Donaldson Co., Inc. All Rights Reserved. Information in the document is subject to change without notice. Donaldson Torit is a registered trademark of Donaldson Company, Inc. Contains Donaldson proprietary technology.