

**ULTRA-WEB®**  
High Efficiency Nanofiber Filters Built to Last



**AT-3000**

A self-contained, continuous cleaning, ceiling-mount general ventilation system.

- Ceiling mount system saves valuable plant floor space, allowing installation in locations previously inaccessible to high efficiency dust collectors.
- Easy filter changeout for quick maintenance.
- Ultra-Web® FR cartridge filters provide high filtration efficiency and long filter life.
- MERV\* 13 filtration efficiency rating per ASHRAE 52.2-2007.
- Recirculation of clean air reduces need for costly make-up air.
- FLUENT®\*\* designed inlet and dust hopper minimize fume re-entrainment and reduce maintenance expense.
- Four small, easy-handling dust pans are lightweight even when full and allow quick dust disposal.
- Provides a cleaner work environment for maximum productivity.

# AMBIENT COLLECTION SYSTEM

## DIMENSIONS & SPECIFICATIONS

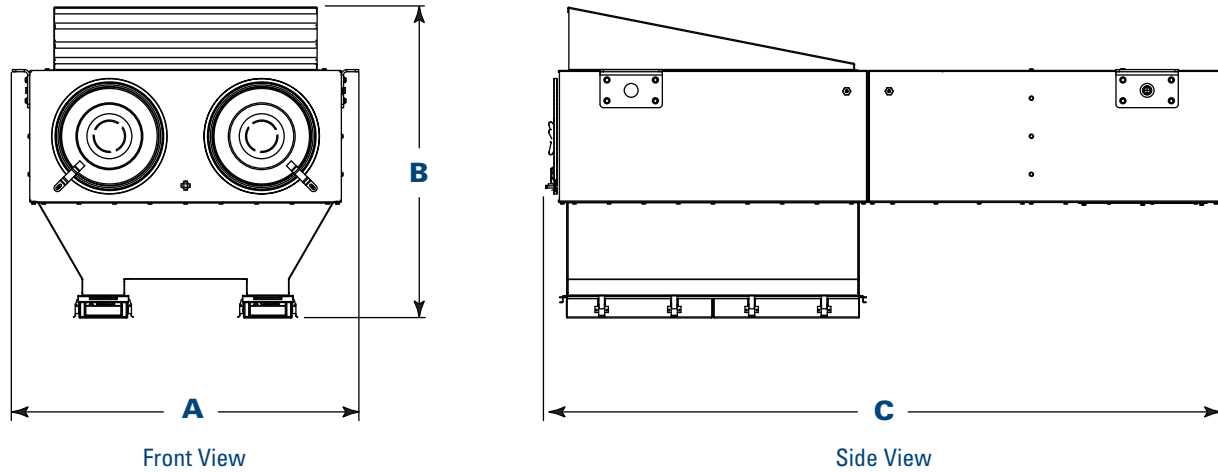

Models	Nominal Airflow Range** (cfm)	Filter Area (ft <sup>2</sup> )	No. of Filters Ultra-Web® FR	No. of 3/4" Valves	Inlet Velocity (fpm)	Dimensions (inches)			Shipping Weight (lbs)	Sound Level dB(A)†
						A	B	C		
AT-3000	2,900	636	4	2	1,325	50.0	44.9	97.4	900	71

## STANDARD FEATURES & AVAILABLE OPTIONS

STANDARD	OPTIONAL
Ultra-Web® FR cartridge filters	Magnehelic®** gauge
208/230/460/60/3 voltage	Photohelic®** gauge
3 hp TEFC blower motor	Hopper
10-year warranty	Solenoid valve silencer

\* The Minimum Efficiency Reporting Value (MERV) of this filter cartridge has been determined through independent laboratory testing using ASHRAE 52.2 (2007) test standards. The MERV rating was determined at a face velocity of 118 feet per minute and loading up to four inches water gauge. Actual efficiency of any filter cartridge will vary according to the specific application parameters. Dust concentration, airflow, particle characteristics, and pulse cleaning methods all affect filtration efficiency.

\*\* FLUENT is a registered trademark of Fluent, Inc. Magnehelic and Photohelic are registered trademarks of Dwyer Instruments, Inc.

\*\*\* Based on clean filters.

† db(A) sound levels are an average of measurements made in a laboratory environment. Installed sound levels will vary depending on the measurement location, operating conditions, and installation.

Significantly improve the performance of your collector with genuine Donaldson Torit replacement filters and parts. [Browse our catalog at donaldson.com](https://www.donaldson.com)



Donaldson Company, Inc.  
Torit  
P.O. Box 1299  
Minneapolis, MN  
55440-1299 U.S.A.

Tel 800-365-1331 (USA)  
Tel 800-343-3639 (within Mexico)

donaldson.com  
donaldson.com



Data Sheet AT-3000 (08/11)

© 1999 Donaldson Co., Inc. All Rights Reserved. Information in the document is subject to change without notice. Donaldson Torit is a registered trademark of Donaldson Company, Inc. Contains Donaldson proprietary technology.